

Technical Support Center: Characterization of Thiomorpholine Derivatives

Author: BenchChem Technical Support Team. **Date:** May 2026

Compound of Interest

Compound Name: *Methyl 4-(thiomorpholin-4-ylmethyl)benzoate*

CAS No.: 128982-45-6

Cat. No.: B2744097

[Get Quote](#)

Status: Active Operator: Senior Application Scientist Ticket ID: TM-ANALYTICAL-GUIDE-v4.2

Subject: Troubleshooting Analytical Anomalies in Thiomorpholine Scaffolds

Introduction: The Thiomorpholine Mandate

Welcome to the technical support hub. If you are here, you are likely encountering data inconsistencies with thiomorpholine-based scaffolds. In modern drug discovery, thiomorpholine is a critical bioisostere of morpholine. By replacing the oxygen with sulfur, you increase lipophilicity (LogP) and alter metabolic stability, but you also introduce a reactive sulfur center and complex conformational dynamics.

This guide addresses the three most common support tickets we receive: NMR signal broadening, unintended oxidation byproducts, and chromatographic co-elution.

Module 1: NMR Spectroscopy Challenges

Symptom: ^1H NMR signals for ring protons (H2, H3, H5, H6) appear broad, undefined, or "missing" at room temperature.

Root Cause Analysis: Conformational Dynamics

Unlike morpholine, the thiomorpholine ring undergoes rapid chair-to-chair inversion and nitrogen pyramidal inversion at room temperature. The energy barrier for this inversion is often comparable to the thermal energy at 298 K (approx. 2.5 kJ/mol).

- The Phenomenon: When the rate of exchange () between conformers is similar to the frequency difference () of the signals, the peaks coalesce, resulting in extreme broadening [1].
- The Trap: Researchers often misinterpret this as paramagnetic impurities or poor shimming.

Troubleshooting Protocol: Variable Temperature (VT) NMR

To resolve this, you must shift the exchange regime to either "Fast" or "Slow."

Step-by-Step Workflow:

- Preparation: Dissolve 5-10 mg of sample in a high-boiling deuterated solvent (e.g., DMSO-
, Toluene-
) or low-freezing solvent (CD₂Cl₂) depending on the target regime.
- High-Temperature Experiment (Fast Exchange):
 - Heat probe to 353 K (80°C) in DMSO-
.
 - Result: Ring flipping accelerates. Signals sharpen into a time-averaged set. Coupling constants () will be averages of axial/equatorial orientations.
- Low-Temperature Experiment (Slow Exchange):
 - Cool probe to 233 K (-40°C) in CD₂Cl₂.

- Result: Ring motion freezes. You will observe distinct signals for axial and equatorial protons.[1] This is required for determining the predominant conformer (e.g., N-substituent axial vs. equatorial) [2].

Visualization: NMR Decision Logic

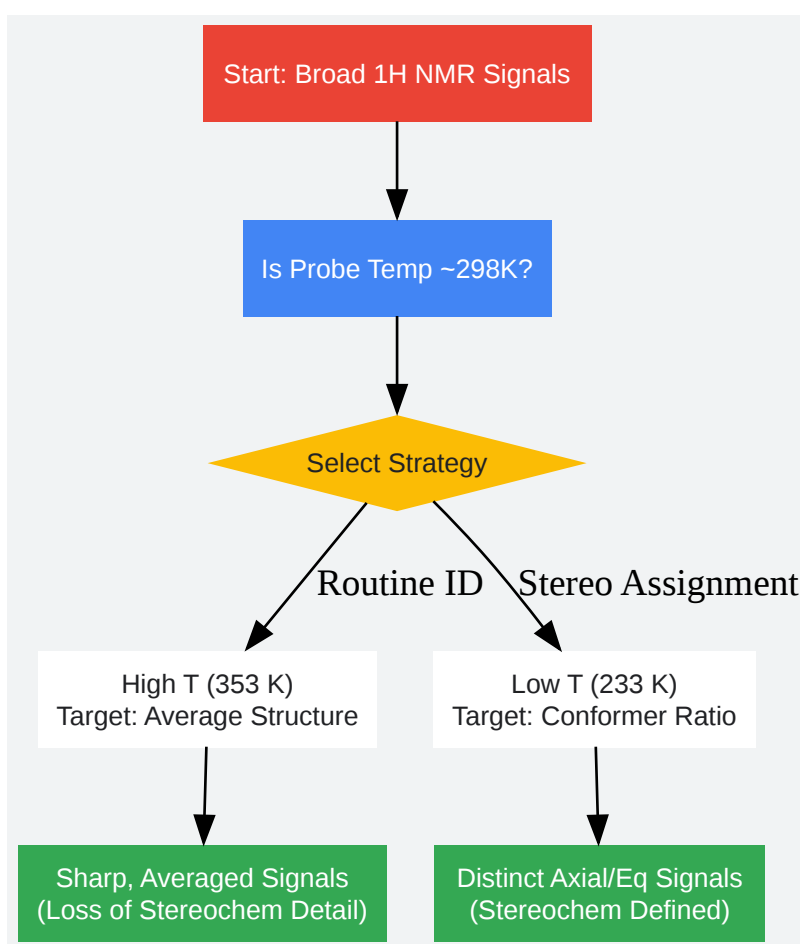

[Click to download full resolution via product page](#)

Caption: Decision tree for resolving thiomorpholine ring fluxionality in NMR spectroscopy.

Module 2: The Oxidation Trap (Sulfoxide/Sulfone)

Symptom: Appearance of satellite peaks in HPLC or unexpected M+16 / M+32 peaks in Mass Spec.

Root Cause Analysis: Sulfur Reactivity

The sulfur atom in thiomorpholine is a "soft" nucleophile and is easily oxidized by atmospheric oxygen, peroxides in solvents (especially ethers/THF), or during workup.

- Sulfoxide (S=O): Chiral center created. If your molecule already has a chiral center, this creates diastereomers (detectable as split peaks in achiral HPLC).
- Sulfone (O=S=O): Achiral, stable, highly polar.

Data Comparison: Identification Matrix

Use this table to distinguish the parent compound from its oxidation byproducts.

Feature	Parent Thiomorpholine	Sulfoxide (S-oxide)	Sulfone (S-dioxide)
Mass Shift ($\Delta m/z$)	Ref (M)	M + 16	M + 32
HPLC Elution (C18)	Late (Lipophilic)	Early (Polar)	Mid-Early (Polar)
Chirality	Achiral*	Chiral (R/S at Sulfur)	Achiral
IR Signature	C-S stretch (600-700 cm^{-1})	S=O (1030-1070 cm^{-1})	O=S=O (1120-1160 cm^{-1})

*Assuming no other chiral centers exist on the scaffold.

Prevention Protocol:

- Solvent Hygiene: Test THF/Dioxane for peroxides using iodide strips before use.
- Degassing: Sparge all HPLC mobile phases with Helium or use an inline degasser.
- Storage: Store thiomorpholine derivatives under Argon at -20°C .

Module 3: Chromatographic Separation (HPLC/UPLC)

Symptom: Poor resolution between the parent thiomorpholine and its polar impurities.

Technical Insight

Thiomorpholine is basic ($pK_a \sim 9.0$ for the conjugate acid). In standard neutral pH reverse-phase (RP) conditions, it may tail significantly due to interaction with residual silanols on the column. Furthermore, the polarity difference between the sulfoxide and sulfone can be subtle [3].

Recommended Method: High pH Reverse Phase

Using a high pH mobile phase suppresses the protonation of the amine, improving peak shape and retention.

Protocol:

- Column: C18 with hybrid particle technology (e.g., XBridge or Gemini NX) capable of pH 10-12 stability.
- Mobile Phase A: 10 mM Ammonium Bicarbonate (pH 10.0).
- Mobile Phase B: Acetonitrile.
- Gradient: 5% B to 95% B over 10 minutes.
- Rationale: At pH 10, the thiomorpholine is neutral (free base), maximizing hydrophobic interaction with the C18 chain and separating it distinctly from the more polar S-oxides.

Visualization: Separation Pathway

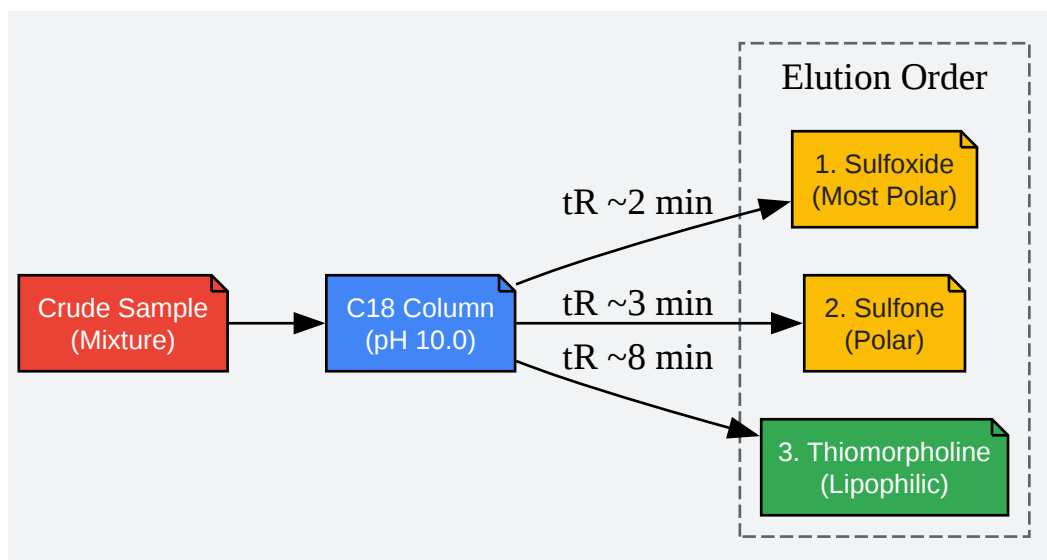

[Click to download full resolution via product page](#)

Caption: Expected elution order of thiomorpholine species in High pH Reverse Phase HPLC.

Module 4: Mass Spectrometry Fragmentation

Symptom: Ambiguous identification of the molecular ion.

Fragmentation Logic

Thiomorpholine derivatives exhibit characteristic fragmentation pathways useful for structural confirmation.

- M+2 Isotope: Sulfur has a naturally occurring isotope (~4.2% abundance). Always check for the M+2 peak to confirm sulfur presence.
- Neutral Loss:
 - Loss of 46 Da: Indicates loss of (thioformaldehyde), characteristic of the thiomorpholine ring opening [4].
 - Loss of 17 Da: If oxidized, sulfoxides often show a characteristic loss of (17 Da) or Oxygen (16 Da) depending on the ionization energy.

References

- Gholivand, K., et al. (2024).[2] Structural Characterization of 4-(4-Nitrophenyl)thiomorpholine, a Precursor in Medicinal Chemistry. MDPI Molbank. Retrieved from [\[Link\]](#)
- Kalogeropoulou, T., et al. (2015). Thiomorpholine Derivatives with Hypolipidemic and Antioxidant Activity. Archiv der Pharmazie. Retrieved from [\[Link\]](#)
- Combès, S., et al. (2022).[3] Synthesis of Thiomorpholine via a Telescoped Photochemical Thiol-ene/Cyclization Sequence in Continuous Flow. ChemRxiv. Retrieved from [\[Link\]](#)

Need Custom Synthesis?

BenchChem offers custom synthesis for rare earth carbides and specific isotopic labeling.

Email: info@benchchem.com or [Request Quote Online](#).

Sources

- [1. pdf.benchchem.com](https://pdf.benchchem.com) [pdf.benchchem.com]
- [2. researchgate.net](https://researchgate.net) [researchgate.net]
- [3. pubs.acs.org](https://pubs.acs.org) [pubs.acs.org]
- To cite this document: BenchChem. [Technical Support Center: Characterization of Thiomorpholine Derivatives]. BenchChem, [2026]. [Online PDF]. Available at: [<https://www.benchchem.com/product/b2744097/docs#technical-support-center-characterization-of-thiomorpholine-derivatives>]

Disclaimer & Data Validity:

The information provided in this document is for Research Use Only (RUO) and is strictly not intended for diagnostic or therapeutic procedures. While BenchChem strives to provide accurate protocols, we make no warranties, express or implied, regarding the fitness of this product for every specific experimental setup.

Technical Support: The protocols provided are for reference purposes. Unsure if this reagent suits your experiment?

Need Industrial/Bulk Grade? [Request Custom Synthesis Quote](#)

BenchChem

Our mission is to be the trusted global source of essential and advanced chemicals, empowering scientists and researchers to drive progress in science and industry.

Contact

Address: 3281 E Guasti Rd

Ontario, CA 91761, United States

Phone: (601) 213-4426

Email: info@benchchem.com

Contact our Ph.D. Support Team for a compatibility check