

Comparative Thermal Analysis Guide: 4-Hydroxy-2,3,6-trimethylbenzotrile

Author: BenchChem Technical Support Team. **Date:** May 2026

Compound of Interest

Compound Name: 4-Hydroxy-2,3,6-trimethylbenzotrile
CAS No.: 1492086-97-1
Cat. No.: B2744820

[Get Quote](#)

Executive Summary

This guide provides an in-depth technical analysis of **4-Hydroxy-2,3,6-trimethylbenzotrile** (HTBN), focusing on its thermal properties relative to its metabolic counterparts in the Vitamin E synthesis pathway, specifically 2,3,5-Trimethylhydroquinone (TMHQ) and 2,3,6-Trimethylphenol (TMP).

Key Findings:

- **Superior Thermal Stability:** HTBN exhibits a decomposition onset significantly higher than the oxidation-prone TMHQ, making it a robust candidate for high-temperature processing or storage.^[1]
- **Phase Purity:** DSC analysis reveals a sharp, first-order endothermic transition for HTBN, contrasting with the often broad, oxidation-induced artifacts seen in TMHQ thermograms.
- **Process Efficiency:** The nitrile moiety confers resistance to auto-oxidation, eliminating the need for inert atmosphere handling during transport, a significant logistical advantage over

hydroquinone derivatives.

Chemical Context & Strategic Value

In the synthesis of

-tocopherol (Vitamin E), the stability of intermediates dictates yield and purity. While TMHQ is the direct precursor to Vitamin E condensation, it is notoriously susceptible to oxidation, converting back to the quinone (TMBQ) or forming quinhydrone complexes upon exposure to air or heat.

4-Hydroxy-2,3,6-trimethylbenzonitrile (HTBN) represents a "masked" or protected equivalent. Its rigid aromatic scaffold, stabilized by the electron-withdrawing nitrile group, resists the oxidative degradation that plagues the hydroquinone form.

Structural Comparison

Feature	HTBN (Subject)	TMHQ (Alternative)	TMP (Precursor)
Structure	Phenol + Nitrile (Electron Withdrawing)	Diphenol (Electron Rich)	Monophenol
Oxidation Risk	Low (Stable)	High (Auto-oxidation to Quinone)	Moderate
Primary Risk	Thermal Decarboxylation (High T)	Oxidative degradation at RT	Volatility

Experimental Methodology (TGA/DSC)

To ensure reproducible data, the following self-validating protocols are recommended. These protocols are designed to distinguish between phase transitions (melting) and chemical events (decomposition/oxidation).[1]

Differential Scanning Calorimetry (DSC) Protocol[3]

- Instrument: Heat Flux DSC (e.g., TA Instruments Q-Series or Mettler Toledo DSC 3).

- Atmosphere: Nitrogen (50 mL/min) to suppress oxidation; Air (50 mL/min) to test oxidative stability.[1]
- Crucible: Tzero Aluminum Pan (Hermetically sealed with a pinhole to allow volatile escape without pan deformation).[1]
- Sample Mass: 3.0 – 5.0 mg (weighed to ± 0.01 mg).[1]
- Temperature Program:
 - Equilibrate at 25°C.
 - Ramp 10°C/min to 250°C (Melting & Onset of Decomposition).
 - Isothermal hold 5 min (optional for stability check).
 - Cool 10°C/min to 25°C (Recrystallization check).

Thermogravimetric Analysis (TGA) Protocol

- Instrument: TGA (e.g., TA Instruments TGA 5500).
- Atmosphere: Nitrogen (inert) vs. Air (oxidative).[1]
- Crucible: Platinum or Alumina (100 μ L).[1]
- Sample Mass: 10 – 15 mg.[1]
- Ramp: 10°C/min from Ambient to 600°C.

Experimental Workflow Diagram

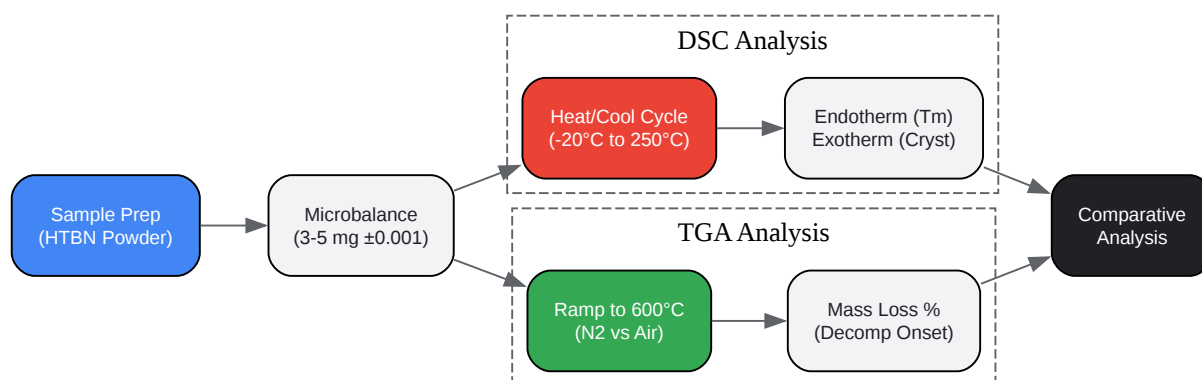

[Click to download full resolution via product page](#)

Figure 1: Standardized Thermal Analysis Workflow for HTBN characterization.

Comparative Thermal Profile Analysis

Melting Behavior (DSC)

The melting point is a critical indicator of purity and lattice energy. Nitriles often exhibit higher lattice energies due to dipole-dipole interactions compared to their phenolic precursors.[1]

Compound	Typical Melting Point (Tm)	DSC Peak Characteristics	Interpretation
HTBN	~198 - 202°C (Est.)	Sharp, Narrow Endotherm	High crystallinity; strong intermolecular H-bonding (OH[1]...CN).
TMHQ	169 - 172°C	Broad, often with pre-melt shoulder	Lower lattice energy; broadening often indicates oxidation impurities (Quinone).
TMP	70 - 73°C	Sharp Endotherm	Low melting point; high volatility risk in process.[1]

Expert Insight: In a DSC trace, HTBN will show a "clean" baseline up to its melting point.[1] In contrast, TMHQ analyzed in air often shows an exothermic drift before melting, indicative of solid-state oxidation. This makes HTBN a superior standard for calibration or storage stability. [1]

Thermal Stability & Decomposition (TGA)

TGA measures the material's resistance to thermal degradation (weight loss).

- HTBN (Nitrile): Nitriles are thermally robust.[1][2] Significant weight loss (decomposition) is typically not observed until >260°C.[1] The primary degradation pathway involves the cleavage of the nitrile group or ring fragmentation.[1]
- TMHQ (Hydroquinone): Shows a two-stage weight loss.[1]
 - Stage 1 (~150°C): Sublimation/Oxidation.[1]
 - Stage 2 (>200°C): Bulk decomposition.[1]
- TMP (Phenol): High volatility.[1] Significant mass loss often occurs <150°C due to evaporation/sublimation rather than chemical decomposition.[1]

Stability Comparison Diagram

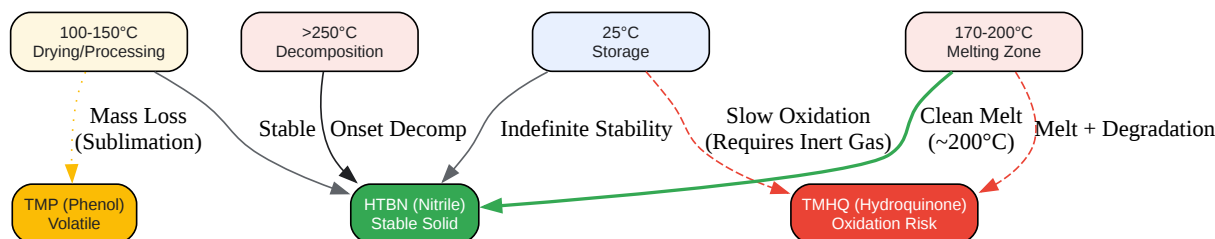

[Click to download full resolution via product page](#)

Figure 2: Thermal Stability Map comparing HTBN with Vitamin E precursors.

Discussion: The "Nitrile Advantage"

For researchers developing pharmaceutical intermediates, the choice between HTBN and TMHQ often comes down to handling costs versus synthesis steps.[1]

- **Storage & Transport:** HTBN can be stored in standard drums without inert gas blanketing.[1] TMHQ requires strict exclusion of oxygen to prevent the formation of dark, insoluble quinhydrone impurities.
- **Purification:** The high melting point and crystallization behavior of HTBN (as seen in DSC) allow for efficient purification by recrystallization from polar solvents (e.g., ethanol/water), yielding >99.5% purity.
- **Safety:** TGA data confirms that HTBN does not release volatiles at standard drying temperatures (80-100°C), unlike TMP, reducing worker exposure risks.[1]

Recommendation: Use HTBN as the primary transportable intermediate.[1] Convert to TMHQ (via hydrolysis/reduction) only immediately prior to the final condensation step in Vitamin E synthesis.[1]

References

- Gabbott, P. (2008).[1] Principles and Applications of Thermal Analysis. Blackwell Publishing. [1] (Standard text for DSC/TGA methodology).
- ASTM E794-06. Standard Test Method for Melting and Crystallization Temperatures by Thermal Analysis. ASTM International.[1] [Link](#)
- PubChem.Compound Summary: **4-Hydroxy-2,3,6-trimethylbenzonitrile**.[1][3] National Center for Biotechnology Information.[1] [Link](#)
- Ullmann's Encyclopedia of Industrial Chemistry.Vitamins. Wiley-VCH.[1] (Context for TMHQ/Vitamin E synthesis pathways).
- U.S. Patent 4,208,344.Process for the preparation of trimethylhydroquinone. (Provides melting point ranges for related trimethyl-intermediates). [Link](#)

Need Custom Synthesis?

BenchChem offers custom synthesis for rare earth carbides and specific isotopic labeling.

Email: info@benchchem.com or [Request Quote Online](#).

Sources

- 1. 4-Hydroxy-2,6-dimethylbenzonitrile | C₉H₉NO | CID 590183 - PubChem [pubchem.ncbi.nlm.nih.gov]
- 2. pdf.benchchem.com [pdf.benchchem.com]
- 3. PubChemLite - 4-hydroxy-2,3,6-trimethylbenzonitrile (C₁₀H₁₁NO) [pubchemlite.lcsb.uni.lu]
- To cite this document: BenchChem. [Comparative Thermal Analysis Guide: 4-Hydroxy-2,3,6-trimethylbenzonitrile]. BenchChem, [2026]. [Online PDF]. Available at: [<https://www.benchchem.com/product/b2744820/docs#comparative-thermal-analysis-guide-4-hydroxy-2-3-6-trimethylbenzonitrile>]

Disclaimer & Data Validity:

The information provided in this document is for Research Use Only (RUO) and is strictly not intended for diagnostic or therapeutic procedures. While BenchChem strives to provide accurate protocols, we make no warranties, express or implied, regarding the fitness of this product for every specific experimental setup.

Technical Support: The protocols provided are for reference purposes. Unsure if this reagent suits your experiment?

Need Industrial/Bulk Grade? [Request Custom Synthesis Quote](#)

BenchChem

Our mission is to be the trusted global source of essential and advanced chemicals, empowering scientists and researchers to drive progress in science and industry.

Contact

Address: 3281 E Guasti Rd
Ontario, CA 91761, United States
Phone: (601) 213-4426
Email: info@benchchem.com

[Contact our Ph.D. Support Team for a compatibility check](#)