

Thermal Stability of Tributylstannyl Triazole Compounds: A Technical Guide

Author: BenchChem Technical Support Team. **Date:** May 2026

Compound of Interest

Compound Name:	<i>1-phenyl-4-(tributylstannyl)-1H-1,2,3-triazole</i>
CAS No.:	619331-68-9
Cat. No.:	B2743980

[Get Quote](#)

Executive Summary

Tributylstannyl (Bu

Sn-) triazoles represent a class of organometallic heterocycles where the thermodynamic stability of the aromatic triazole ring contrasts with the kinetic lability of the tin-carbon (C-Sn) or tin-nitrogen (N-Sn) bond. While the 1,2,3-triazole core is thermally resilient up to ~300°C, the tributylstannyl moiety introduces a specific thermal ceiling, typically governed by destannylation or homolytic bond cleavage rather than ring fragmentation.

This guide distinguishes between C-stannyl (4- or 5-substituted) and N-stannyl (1- or 2-substituted) isomers, as their thermal profiles and handling requirements differ fundamentally.

Structural Dynamics & Thermal Vulnerabilities

The thermal stability of these compounds is dictated by the bond dissociation energy (BDE) of the attachment point of the tin atom.

The Stability Hierarchy

Compound Class	Bond Type	Approx. Thermal Limit	Primary Degradation Mode
C-Stannyl (4/5-Bu Sn)		150°C – 180°C	Protodestannylation (in presence of protons) or Homolysis
N-Stannyl (1/2-Bu Sn)		< 100°C	Hydrolysis (moisture sensitive) & N-migration
Triazole Core		> 250°C	Ring fragmentation / Nitrogen extrusion

Mechanistic Insight: The C-Sn Bond

In C-tributylstannyl-1,2,3-triazoles (commonly used in radiochemistry), the C-Sn bond is relatively robust due to the

hybridization of the triazole carbon. However, at elevated temperatures (>150°C), the bond becomes susceptible to homolytic cleavage, particularly in the presence of radical initiators or oxidants.

Critical Note: The triazole ring acts as an electron-withdrawing group (EWG) relative to the tin. This polarization stabilizes the C-Sn bond against random thermal homolysis but activates it for electrophilic substitution (e.g., iododestannylation).

Synthesis Pathways & Thermal History

The method of synthesis dictates the thermal history and isomeric purity of the compound.

The "Interrupted Click" Synthesis

A dominant modern protocol involves the Copper-Catalyzed Azide-Alkyne Cycloaddition (CuAAC) interrupted by a tin reagent. This method avoids high temperatures, preserving the C-Sn bond.

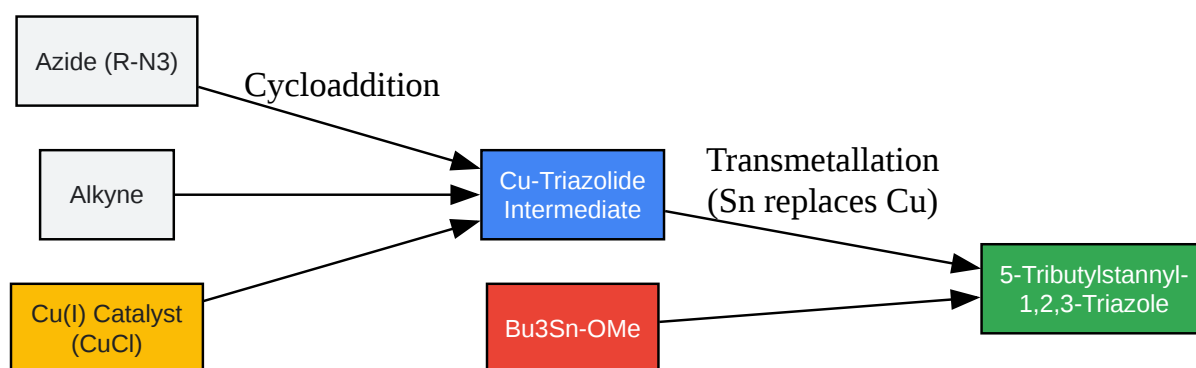

[Click to download full resolution via product page](#)

Figure 1: The "Interrupted Click" pathway allows the installation of the tributylstannyl group at the 5-position under mild conditions (Room Temp to 60°C), preventing premature thermal degradation.

Thermal Rearrangement Risks

During synthesis or purification (e.g., distillation), N-substituted triazoles can undergo Dimroth rearrangement or alkyl group migration at temperatures exceeding 120°C. For stannyl derivatives, high heat often leads to "tin scrambling," where the Bu

Sn group migrates between N and C atoms or disproportionates into Bu

Sn and inorganic tin residues.

Applications: Handling Under Thermal Stress Radioiodination (Iododestannylation)

The primary pharmaceutical application is using the tributylstannyl group as a "leaving group" to install radioactive iodine (

I,

I, or

I).

- Reaction Conditions: Typically requires oxidants (e.g., Chloramine-T, peracetic acid) and mild heat (Room Temp to 80°C).

- **Thermal Bottleneck:** If the reaction temperature exceeds 100°C, competing protodestannylation (replacement of Sn by H) accelerates, reducing the radiochemical yield (RCY).

Stille Cross-Coupling

When used as a nucleophile in Pd-catalyzed coupling:

- **Solvent Choice:** High-boiling solvents like DMF or NMP are often used.
- **Stability Protocol:** The reaction temperature should be kept below 110°C. Above this, the rate of "homocoupling" (triazole-triazole dimerization) increases significantly due to thermal instability of the Pd-transmetallated intermediate.

Experimental Protocols

Protocol A: Thermal Stability Assessment (TGA/DSC)

Use this protocol to validate the shelf-life and processing limits of your specific derivative.

- **Preparation:** Dry the tributylstannyl triazole sample under high vacuum (0.1 mmHg) for 4 hours to remove trace solvents (solvents can mimic degradation weight loss).
- **Instrument:** Simultaneous TGA/DSC (e.g., TA Instruments SDT 650).
- **Atmosphere:** Nitrogen () purge at 50 mL/min (Inert environment is crucial to distinguish thermal homolysis from oxidative degradation).
- **Ramp:** Heat from 25°C to 400°C at 10°C/min.
- **Data Analysis:**
 - **(Decomposition):** Record the temperature at 5% weight loss. For stable C-stannyl triazoles, this should be >180°C.
 - **Endotherms:** Look for melting peaks.^[1]

- Exotherms: Sharp exotherms $<200^{\circ}\text{C}$ indicate rapid decomposition or explosive potential (rare for stannyls, but possible with nitro-triazoles).

Protocol B: Purification of Thermally Sensitive Stannyl Triazoles

Avoid Gas Chromatography (GC) due to high injection port temperatures.

- Column Chromatography: Use silica gel pre-treated with 1% triethylamine (TEA).
 - Reasoning: Silica is slightly acidic. Acid protons can cause protodestannylation. TEA neutralizes the silica, preserving the C-Sn bond.
- Elution: Use Hexane/Ethyl Acetate gradients. Avoid chlorinated solvents if storing for long periods, as they can generate HCl traces over time.
- Drying: Rotary evaporate at bath temperatures $< 40^{\circ}\text{C}$.

Degradation & Substitution Mechanism

Understanding the cleavage pathway is essential for optimizing labeling reactions.

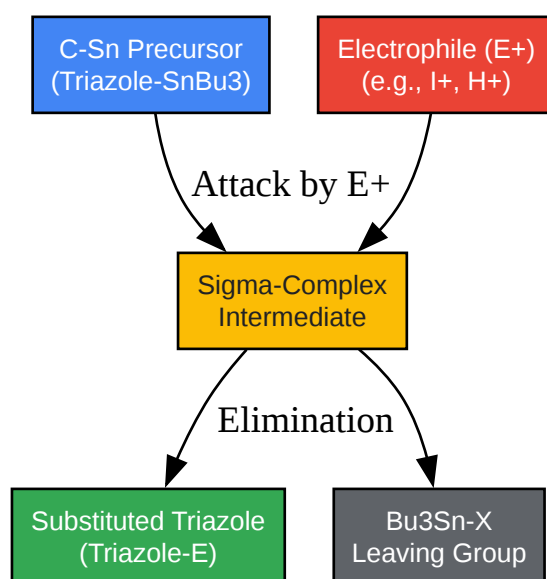

[Click to download full resolution via product page](#)

Figure 2: The electrophilic destannylation mechanism. Thermal energy helps overcome the activation barrier for the Sigma-complex formation, but excessive heat leads to competing side reactions.

References

- Synthesis of 5-Stannyl Triazoles via Interrupted Click Reaction
 - Title: Bench-Stable 5-Stannyl Triazoles by a Copper(I)
 - Source: Organic Letters (2022).[2]
 - URL:[Link][2]
- Thermal Stability of Triazole Polymers
 - Title: Synthesis of Dense 1,2,3-Triazole Polymers Soluble in Common Organic Solvents. [3]
 - Source: MDPI (Polymers).
 - URL:[Link]
- Stille Coupling Applic
 - Title: Stille reaction: A pivotal palladium-c
 - Source: Wikipedia / Organic Chemistry Portal (General Reference).
 - URL:[Link]
- Triazole Radioiodin
 - Title: Synthesis and evaluation of 1,2,3-triazole based radiotracers.
 - Source: N
 - URL:[Link]
- Thermal Rearrangement Mechanisms
 - Title: Thermal Rearrangement of Allyl Substituted Unsymmetric 4H-1,2,4-Triazoles.

- Source: Acta Chemica Scandinavica.
- URL:[[Link](#)]

Need Custom Synthesis?

BenchChem offers custom synthesis for rare earth carbides and specific isotopic labeling.

Email: info@benchchem.com or [Request Quote Online](#).

Sources

- [1. Investigation of 1,4-Substituted 1,2,3-Triazole Derivatives as Antiarrhythmics: Synthesis, Structure, and Properties - PMC \[pmc.ncbi.nlm.nih.gov\]](#)
- [2. Versatile Synthetic Platform for 1,2,3-Triazole Chemistry - PMC \[pmc.ncbi.nlm.nih.gov\]](#)
- [3. mdpi.com \[mdpi.com\]](#)
- To cite this document: BenchChem. [Thermal Stability of Tributylstannyl Triazole Compounds: A Technical Guide]. BenchChem, [2026]. [Online PDF]. Available at: [<https://www.benchchem.com/product/b2743980/docs#thermal-stability-of-tributylstannyl-triazole-compounds-a-technical-guide>]

Disclaimer & Data Validity:

The information provided in this document is for Research Use Only (RUO) and is strictly not intended for diagnostic or therapeutic procedures. While BenchChem strives to provide accurate protocols, we make no warranties, express or implied, regarding the fitness of this product for every specific experimental setup.

Technical Support: The protocols provided are for reference purposes. Unsure if this reagent suits your experiment?

Need Industrial/Bulk Grade? [Request Custom Synthesis Quote](#)

BenchChem

Our mission is to be the trusted global source of essential and advanced chemicals, empowering scientists and researchers to drive progress in science and industry.

Contact

Address: 3281 E Guasti Rd

Ontario, CA 91761, United States

Phone: (601) 213-4426

Email: info@benchchem.com

[Contact our Ph.D. Support Team for a compatibility check](#)