

Assessing the Environmental Impact of Organotin Reagents in Synthesis

Author: BenchChem Technical Support Team. **Date:** May 2026

Compound of Interest

Compound Name: *1-phenyl-4-(tributylstannyl)-1H-1,2,3-triazole*
CAS No.: 619331-68-9
Cat. No.: B2743980

[Get Quote](#)

Content Type: Technical Comparison Guide Audience: Researchers, Process Chemists, and Drug Development Professionals

Executive Summary: The "Tin Problem" in Modern Synthesis

For decades, organotin reagents—specifically tributyltin hydride (Bu_3SnH) and stannanes used in Stille couplings—have been the "gold standard" for radical reductions and C-C bond formation due to their high reactivity and chemoselectivity. However, their utility comes at a steep price: severe environmental persistence, high toxicity to aquatic life, and notorious difficulty in purification.

As pharmaceutical manufacturing moves toward Green Chemistry principles and stricter regulatory compliance (REACH, ICH Q3D), the use of organotins has become a critical liability. This guide objectively compares organotin reagents with their modern, eco-friendly alternatives—Tris(trimethylsilyl)silane (TTMSS) and Organoboron reagents—providing experimental data, mechanistic insights, and validated protocols to support the transition away from tin.

The Case Against Organotins: Toxicology & Regulation

Environmental & Biological Toxicity

Organotins are not merely toxic; they are endocrine disruptors. Tributyltin (TBT) causes "imposex" (development of male characteristics in females) in marine gastropods at concentrations as low as 1 ng/L. In humans, they are immunotoxic and neurotoxic.[1]

Feature	Tributyltin (Bu ₃ SnX)	Organoboron (Suzuki)	Organosilane (TTMSS)
Aquatic Toxicity	Extreme (Marine pollutant)	Low	Low
Bioaccumulation	High (Lipophilic)	Low	Low
Regulatory Status	Restricted (REACH Annex XVII)	Generally Safe	Generally Safe
ICH Q3D Class	Class 3 (Sn)*	Class 2B (B)	Low Concern (Si)

*Note: While elemental Tin is Class 3 (PDE 6000 μ g/day), organic TBT residues are often flagged as potential genotoxic impurities (PGIs) or Substances of Very High Concern (SVHC), requiring limits far below the elemental standard.

The Purification Bottleneck

The "hidden cost" of tin is in the workup. Organotin byproducts (e.g., Bu₃SnX) are lipophilic, often co-eluting with non-polar products during chromatography. Removing tin residues to pharmaceutical standards (<10–20 ppm) often requires multiple purifications, destroying the E-factor (waste-to-product ratio) of the process.

Scenario A: Radical Reduction (H-Atom Donors)

The Standard: Tributyltin Hydride (Bu₃SnH) The Alternative: Tris(trimethylsilyl)silane (TTMSS)

Mechanistic Comparison

Both reagents function as H-atom donors in radical chains. However, TTMSS (often called "Supersilane") offers a weaker Si-H bond (79 kcal/mol) compared to typical silanes, closely mimicking the reactivity profile of Sn-H (74 kcal/mol) but without the toxicity.

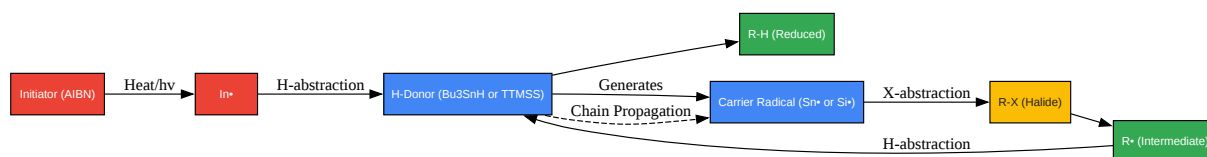

[Click to download full resolution via product page](#)

Figure 1: General radical chain propagation cycle valid for both Tin and Silane reagents.

Performance Data: Diastereoselective Cyclization

In the synthesis of 2,4-disubstituted piperidines (common drug pharmacophores), TTMSS often outperforms Bu_3SnH in stereoselectivity due to the bulkier silyl radical.

Metric	Bu_3SnH (Tin)	TTMSS (Silicon)
Yield	85%	89%
Diastereomeric Ratio (trans:cis)	2:1	15:1
Workup	Complex (KF wash/Chromatography)	Simple (Evaporation/Hydrolysis)
Toxicity	High	Low

Protocol: Green Radical Reduction using TTMSS

Objective: Reductive dehalogenation of an alkyl bromide.

- Setup: In a flame-dried flask, dissolve alkyl bromide (1.0 equiv) in degassed toluene (0.1 M).

- Reagent Addition: Add TTMSS (1.1 equiv) and AIBN (0.1 equiv).
- Reaction: Heat to 80°C for 2–4 hours under Argon. Monitor by TLC.
- Workup (The "Green" Advantage):
 - Cool to room temperature.
 - Remove solvent in vacuo.
 - Crucial Step: The byproduct $(\text{TMS})_3\text{Si-Br}$ is volatile or easily hydrolyzed. Add methanol (5 mL) and stir for 30 mins to convert silyl byproducts to siloxanes/silanols.
 - Concentrate and purify via short silica plug (non-polar siloxanes elute with solvent front; product follows).

Scenario B: C-C Bond Formation (Cross-Coupling)

The Standard: Stille Coupling (Organotin) The Alternative: Suzuki-Miyaura Coupling (Organoboron)

Comparative Analysis

While Stille coupling is chemically robust (neutral conditions), the Suzuki coupling has eclipsed it in industrial applications due to the benign nature of boronic acids.

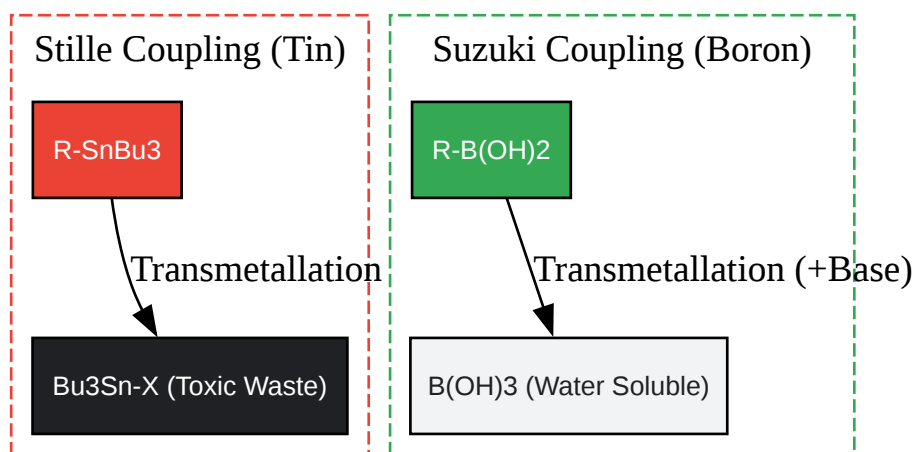

[Click to download full resolution via product page](#)

Figure 2: Waste stream comparison. Stille generates persistent toxic waste; Suzuki generates water-soluble boric acid.

Experimental Data: Biaryl Synthesis

Comparing the synthesis of 4-phenyltoluene.

Parameter	Stille Coupling	Suzuki Coupling
Reagent	Tributyl(phenyl)stannane	Phenylboronic Acid
Catalyst	Pd(PPh ₃) ₄	Pd(OAc) ₂ / SPhos
Base Required?	No	Yes (K ₂ CO ₃)
Atom Economy	Poor (Loss of massive SnBu ₃ group)	Excellent (Loss of B(OH) ₂)
Purification	Difficult (Sn residues)	Easy (Aq. wash removes Boron)
E-Factor (kg waste/kg product)	~25–50	< 10

Deep Dive: Managing Tin Residues (If You Must Use Tin)

Sometimes, Stille chemistry is unavoidable (e.g., complex natural product synthesis where basic Suzuki conditions degrade the substrate). In these cases, removal of tin is the primary compliance requirement.

Protocol: The KF/Silica Remediation Method

This method relies on the formation of insoluble polymeric tributyltin fluoride.

- Reaction End: Dilute the crude reaction mixture with Ether or EtOAc.
- Treatment: Add a saturated aqueous solution of Potassium Fluoride (KF) (approx. 10 mL per gram of stannane used) and solid Celite.

- Agitation: Stir vigorously for 2 hours. The lipophilic Bu_3SnX converts to insoluble polymeric $[\text{Bu}_3\text{SnF}]_n$.
- Filtration: Filter the resulting slurry through a pad of silica/Celite.[2] The tin polymer remains on the filter.
- Validation: Analyze the filtrate via ICP-MS.
 - Standard Extraction: Typically leaves ~1000–5000 ppm Sn.
 - KF/Silica Method: Typically reduces Sn to < 50 ppm.

Conclusion & Future Outlook

The environmental and regulatory cost of organotin reagents now outweighs their synthetic convenience in most applications.

- For Radical Chemistry: TTMSS is a drop-in replacement that maintains reactivity while eliminating toxicity and simplifying workup.[3]
- For Cross-Coupling: Suzuki-Miyaura is the superior process choice, offering better atom economy and water-soluble waste streams.

Recommendation: Drug development workflows should default to Boron or Silicon-based methodologies. Organotins should be reserved only as a "reagent of last resort" for substrates intolerant to basic conditions, and must always be paired with rigorous remediation protocols (KF treatment) to meet ICH Q3D guidelines.

References

- Tributyltin Toxicity & Regulation: European Commission. (2009).[4] Decision No 406/2009/EC on the effort of Member States to reduce their greenhouse gas emissions.
- ICH Q3D Guidelines: International Council for Harmonisation. (2019). Guideline Q3D(R1) on elemental impurities.
- TTMSS vs Tin Performance: Chatgililoglu, C. (2001). Organosilanes as Radical-Based Reducing Agents in Synthesis.[5]

- Tin Removal Methods:Harrowven, D. C., & Guy, I. L. (2004). KF/Silica as a stationary phase for the removal of tin residues.[2][6][7]
- Green Coupling Comparison:Constable, D. J. C., et al. (2007). Key green chemistry research areas—a perspective from pharmaceutical manufacturers.

Need Custom Synthesis?

BenchChem offers custom synthesis for rare earth carbides and specific isotopic labeling.

Email: info@benchchem.com or [Request Quote Online](#).

Sources

- [1. chromatographyonline.com](http://1.chromatographyonline.com) [chromatographyonline.com]
- [2. pdf.benchchem.com](http://2.pdf.benchchem.com) [pdf.benchchem.com]
- [3. Tributylgermanium hydride as a replacement for tributyltin hydride in radical reactions - Organic & Biomolecular Chemistry \(RSC Publishing\)](#) [pubs.rsc.org]
- [4. Stille vs. Suzuki – cross-coupling for the functionalization of diazocines - PMC](#) [pmc.ncbi.nlm.nih.gov]
- [5. Tris\(trimethylsilyl\)silane, TTMSS](#) [organic-chemistry.org]
- [6. Workup](#) [chem.rochester.edu]
- [7. sdlookchem.com](#) [sdlookchem.com]
- To cite this document: BenchChem. [Assessing the Environmental Impact of Organotin Reagents in Synthesis]. BenchChem, [2026]. [Online PDF]. Available at: [https://www.benchchem.com/product/b2743980/docs#assessing-the-environmental-impact-of-organotin-reagents-in-synthesis]

Disclaimer & Data Validity:

The information provided in this document is for Research Use Only (RUO) and is strictly not intended for diagnostic or therapeutic procedures. While BenchChem strives to provide accurate protocols, we make no warranties, express or implied, regarding the fitness of this product for every specific experimental setup.

Technical Support: The protocols provided are for reference purposes. Unsure if this reagent suits your experiment?

Need Industrial/Bulk Grade? [Request Custom Synthesis Quote](#)

BenchChem

Our mission is to be the trusted global source of essential and advanced chemicals, empowering scientists and researchers to drive progress in science and industry.

Contact

Address: 3281 E Guasti Rd
Ontario, CA 91761, United States
Phone: (601) 213-4426
Email: info@benchchem.com

[Contact our Ph.D. Support Team for a compatibility check](#)