

A Researcher's Guide to Evaluating Novel Pyrazole Compounds: A Comparative Analysis

Author: BenchChem Technical Support Team. **Date:** May 2026

Compound of Interest

Compound Name: 4-[(4-chloro-1H-pyrazol-1-yl)methyl]oxan-4-ol
CAS No.: 2167087-06-9
Cat. No.: B2739733

[Get Quote](#)

For decades, the pyrazole scaffold has served as a cornerstone in medicinal chemistry, yielding a multitude of compounds with diverse biological activities. The inherent versatility of this five-membered heterocyclic ring allows for extensive structural modifications, making it a privileged scaffold in the quest for novel therapeutics. This guide provides a comprehensive framework for the peer review and comparative analysis of novel pyrazole compounds, with a particular focus on their role as kinase inhibitors in oncology. We will delve into the critical experimental workflows required to validate their efficacy and selectivity, comparing them against established alternatives.

The Kinase Inhibitor Landscape: Where Do Pyrazoles Fit In?

The protein kinase family represents one of the most critical targets in modern drug discovery, particularly in oncology. Their dysregulation is a hallmark of many cancers, making them prime targets for therapeutic intervention. While numerous kinase inhibitors have reached the market, the challenges of acquired resistance and off-target toxicity necessitate a continuous search for novel chemical matter.

Novel pyrazole compounds often emerge as promising candidates due to their ability to form key hydrogen bond interactions within the ATP-binding pocket of kinases. This guide will use a hypothetical novel pyrazole compound, "Pyr-2026," as a case study to illustrate the evaluation process against a known pan-kinase inhibitor like Staurosporine and a more selective, clinically approved drug such as Sunitinib.

Comparative Efficacy and Selectivity: A Data-Driven Approach

A rigorous evaluation of any new compound hinges on robust, quantitative data. The following sections outline the essential experiments and how to present the resulting data for a clear, comparative analysis.

In Vitro Kinase Inhibition Assays

The initial assessment of a novel pyrazole compound involves determining its inhibitory activity against a panel of relevant kinases. This is crucial for establishing both its potency and its selectivity profile.

Table 1: Comparative Kinase Inhibition Profile (IC₅₀, nM)

Kinase Target	Pyr-2026 (Hypothetical)	Staurosporine	Sunitinib
VEGFR2	15	7.9	9
PDGFR β	25	8.5	2
c-KIT	40	7.5	8
FLT3	35	5.8	1
SRC	850	6.2	>10,000
ABL	>10,000	22	30

Data presented is for illustrative purposes.

This table immediately highlights the potential advantages and disadvantages of Pyr-2026. While less potent than the non-selective Staurosporine, it shows a favorable selectivity profile by sparing key off-targets like SRC and ABL, a desirable trait for minimizing toxicity. Compared to Sunitinib, it may offer a different spectrum of activity that could be advantageous in specific cancer types.

Cellular Potency and Viability Assays

Demonstrating target engagement and downstream functional effects in a cellular context is a critical next step.

Table 2: Cellular Activity in Relevant Cancer Cell Lines (EC50, μM)

Cell Line (Cancer Type)	Pyr-2026 (Hypothetical)	Staurosporine	Sunitinib
HUVEC (Endothelial)	0.5	0.01	0.2
A549 (Lung Carcinoma)	1.2	0.05	0.8
K562 (CML)	>20	0.1	0.5

Data presented is for illustrative purposes.

These results would suggest that Pyr-2026 has potent anti-proliferative effects in cell lines where the targeted kinases are key drivers of growth (e.g., HUVEC and A549) and is less active in cell lines dependent on kinases it does not inhibit (e.g., K562, which is ABL-dependent).

Experimental Protocols: A Step-by-Step Guide

To ensure scientific rigor and reproducibility, detailed protocols are essential. The following are standard methodologies for the experiments cited above.

Protocol 1: In Vitro Kinase Inhibition Assay (LanthaScreen™ Eu Kinase Binding Assay)

This time-resolved fluorescence resonance energy transfer (TR-FRET) assay is a common method for quantifying kinase-inhibitor interactions.

Step-by-Step Methodology:

- **Reagent Preparation:** Prepare a solution of the kinase, a fluorescently labeled ATP-competitive tracer, and a europium-labeled anti-tag antibody.
- **Compound Dilution:** Create a serial dilution of the test compounds (Pyr-2026, Staurosporine, Sunitinib) in DMSO.
- **Assay Plate Preparation:** Add the kinase, tracer, and antibody solution to a 384-well microplate.
- **Compound Addition:** Transfer the diluted compounds to the assay plate.
- **Incubation:** Incubate the plate at room temperature for 1 hour to allow the binding reaction to reach equilibrium.
- **Data Acquisition:** Read the plate on a TR-FRET-compatible plate reader, measuring the emission at two wavelengths (e.g., 665 nm and 615 nm).
- **Data Analysis:** Calculate the emission ratio and plot the results against the compound concentration to determine the IC50 value.

Protocol 2: Cell Viability Assay (MTT Assay)

The MTT assay is a colorimetric assay for assessing cell metabolic activity, which is an indicator of cell viability.

Step-by-Step Methodology:

- **Cell Seeding:** Seed cancer cells in a 96-well plate at a predetermined density and allow them to adhere overnight.
- **Compound Treatment:** Treat the cells with a serial dilution of the test compounds for 72 hours.

- MTT Addition: Add MTT (3-(4,5-dimethylthiazol-2-yl)-2,5-diphenyltetrazolium bromide) solution to each well and incubate for 4 hours.
- Solubilization: Add a solubilizing agent (e.g., DMSO or a detergent solution) to dissolve the formazan crystals.
- Absorbance Reading: Measure the absorbance at 570 nm using a microplate reader.
- Data Analysis: Normalize the absorbance values to the vehicle-treated control and plot against the compound concentration to calculate the EC50.

Visualizing the Rationale: Signaling Pathways and Workflows

Diagrams are invaluable tools for conveying complex biological pathways and experimental designs.

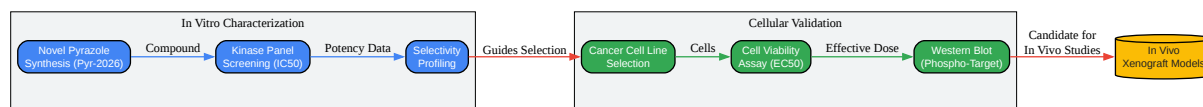

[Click to download full resolution via product page](#)

Caption: High-level workflow for the evaluation of a novel pyrazole compound.

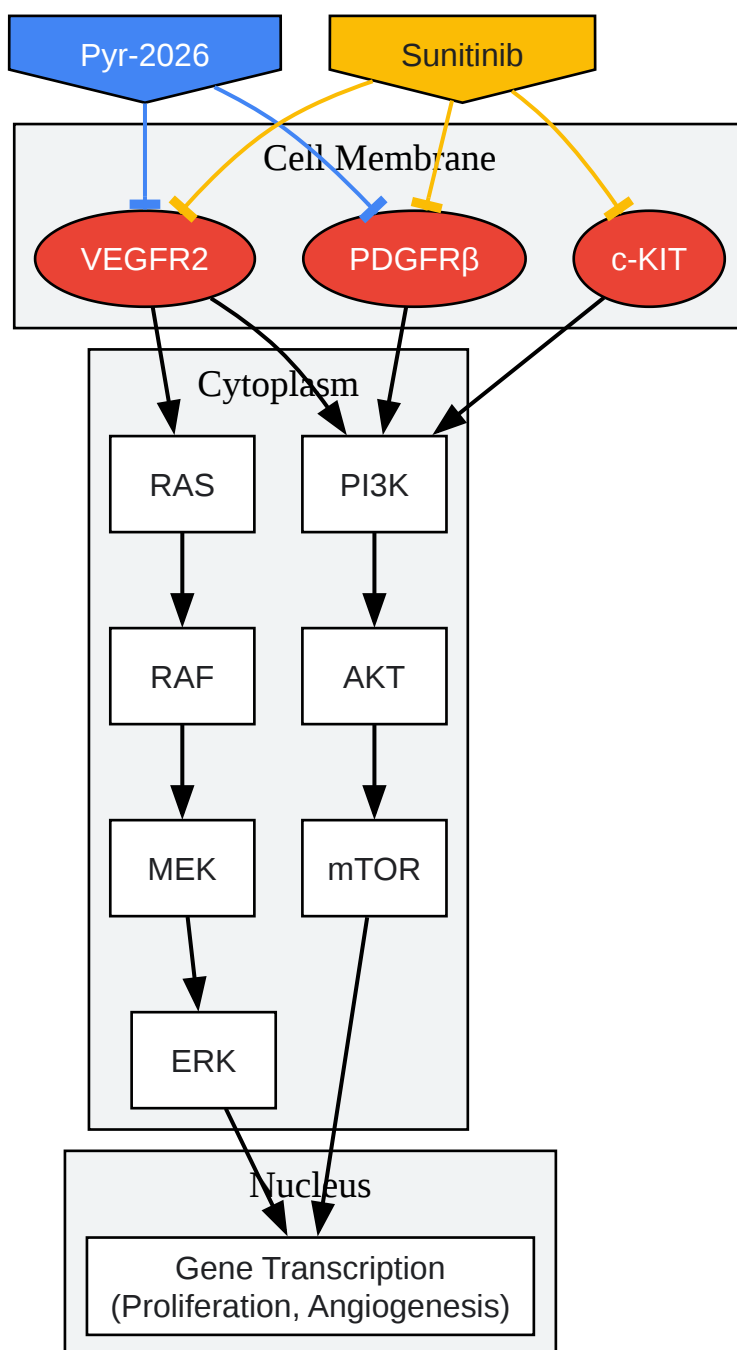

[Click to download full resolution via product page](#)

Caption: Simplified signaling pathway inhibited by Pyr-2026 and Sunitinib.

Conclusion and Future Directions

The initial characterization of "Pyr-2026" demonstrates a promising profile for a novel kinase inhibitor. Its selectivity, as determined by in vitro kinase screening, and its on-target cellular

potency suggest a potentially wider therapeutic window compared to less selective agents. The provided protocols offer a standardized approach for other researchers to validate and compare their own novel pyrazole compounds.

Further studies should focus on elucidating the binding kinetics of Pyr-2026, conducting in vivo efficacy studies in relevant animal models, and performing comprehensive ADME/Tox profiling to fully assess its drug-like properties. This structured, comparative approach is paramount for the efficient and successful development of the next generation of pyrazole-based therapeutics.

References

- The Pyrazole Scaffold in Medicinal Chemistry: Molecules. A review article discussing the diverse applications of pyrazole derivatives in drug discovery. [\[Link\]](#)
- Sunitinib (Sutent): FDA. Prescribing information for Sunitinib, detailing its mechanism of action and clinical use. [\[Link\]](#)
- [To cite this document: BenchChem. \[A Researcher's Guide to Evaluating Novel Pyrazole Compounds: A Comparative Analysis\]. BenchChem, \[2026\]. \[Online PDF\]. Available at: \[https://www.benchchem.com/product/b2739733/docs#a-researcher-s-guide-to-evaluating-novel-pyrazole-compounds-a-comparative-analysis\]](#)

Disclaimer & Data Validity:

The information provided in this document is for Research Use Only (RUO) and is strictly not intended for diagnostic or therapeutic procedures. While BenchChem strives to provide accurate protocols, we make no warranties, express or implied, regarding the fitness of this product for every specific experimental setup.

Technical Support: The protocols provided are for reference purposes. Unsure if this reagent suits your experiment?

Need Industrial/Bulk Grade? [Request Custom Synthesis Quote](#)

BenchChem

Our mission is to be the trusted global source of essential and advanced chemicals, empowering scientists and researchers to drive progress in science and industry.

Contact

Address: 3281 E Guasti Rd

Ontario, CA 91761, United States

Phone: (601) 213-4426

Email: info@benchchem.com

[Contact our Ph.D. Support Team for a compatibility check](#)