

Application Note: Formulating 7-Methylquinoline-4-carboxylic Acid for Biological Assays

Author: BenchChem Technical Support Team. **Date:** May 2026

Compound of Interest

| | |
|----------------|-------------------------------------|
| Compound Name: | 7-Methylquinoline-4-carboxylic acid |
| CAS No.: | 816448-99-4 |
| Cat. No.: | B2737832 |

[Get Quote](#)

Introduction: The Solubility Paradox

7-Methylquinoline-4-carboxylic acid is a critical scaffold in medicinal chemistry, serving as a precursor for DNA gyrase inhibitors (antibacterials), DHODH inhibitors (anticancer), and fluorescent probes. However, its utility in biological assays is frequently compromised by its zwitterionic nature.

At neutral pH, the compound exists in an equilibrium that favors poor solubility. The basic quinoline nitrogen (

) and the acidic carboxylic acid (

) can lead to isoelectric precipitation in standard buffers like PBS. This guide provides a validated protocol to solubilize, dilute, and deliver this molecule into biological systems without precipitation or vehicle-induced toxicity.

Physicochemical Profile & Formulation Logic

Before formulation, one must understand the ionization states that dictate solubility.

| Property | Value | Implication for Formulation |
|----------------------|--------------|--|
| Molecular Weight | 187.20 g/mol | Small molecule; rapid diffusion. |
| LogP (Predicted) | -2.3 | Moderately lipophilic; requires organic co-solvent or pH adjustment. |
| Acidic pKa (COOH) | -2.5 | Deprotonated (anionic) at physiological pH (7.4). |
| Basic pKa (N-ring) | -5.2 | Uncharged at physiological pH (7.4). |
| Solubility (Water) | < 1 mg/mL | Insoluble as a free acid. |
| Solubility (DMSO) | > 50 mM | Excellent solvent for stock solutions. |
| Solubility (1N NaOH) | Soluble | Forms the highly soluble sodium salt. |

Mechanistic Insight: The pH Switch

To achieve aqueous stability, we must force the molecule into its anionic state. By raising the pH above the isoelectric point, we convert the insoluble free acid into the soluble 7-methylquinoline-4-carboxylate anion.

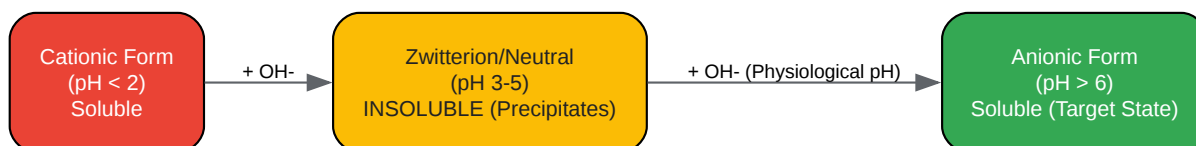

Figure 1: Solubility relies on avoiding the isoelectric zwitterionic region (pH 3-5).

[Click to download full resolution via product page](#)

Protocol A: DMSO Stock Formulation (Standard)

Best for: High-throughput screening, enzymatic assays, and robust cell lines.

Reagents:

- **7-Methylquinoline-4-carboxylic acid** (Solid)
- Anhydrous DMSO (Dimethyl Sulfoxide), Cell Culture Grade ($\geq 99.9\%$)

Procedure:

- **Calculate:** Determine the mass required for a 50 mM stock.
 - Example: To make 1 mL of 50 mM stock, weigh 9.36 mg.
- **Dissolve:** Add the calculated volume of anhydrous DMSO to the vial.
- **Sonicate:** Sonicate in a water bath at room temperature for 5-10 minutes.
 - **Critical Check:** Visually inspect for "swirling" particulates. The solution must be crystal clear.
- **Storage:** Aliquot into amber glass vials (DMSO leaches plastic). Store at -20°C .
 - **Stability:** Stable for 6 months. Avoid repeated freeze-thaw cycles (max 3).

Protocol B: Sodium Salt Aqueous Formulation (Advanced)

Best for: DMSO-sensitive primary cells, in vivo studies, or high-concentration treatments.

Reagents:

- 0.1 M NaOH (Sodium Hydroxide)
- PBS (Phosphate Buffered Saline), pH 7.4

Procedure:

- Weigh: Weigh 18.7 mg of compound (approx. 100 μ mol).
- Alkaline Dissolution: Add 1.0 mL of 0.1 M NaOH.
 - Mechanism:[1][2] This provides a 1:1 molar equivalent of base to deprotonate the carboxylic acid, forming the sodium salt in situ.
- Vortex: Vortex vigorously until fully dissolved. The solution should be clear.
- Buffer: Slowly dilute this 100 mM stock into PBS or media.
 - Note: Check pH after dilution. The buffering capacity of PBS is usually sufficient to neutralize the small amount of NaOH added, but verify pH is 7.2–7.6.

Biological Assay Execution: Preventing "Crash-Out"

The most common failure mode is precipitation when a high-concentration DMSO stock hits aqueous media. This creates micro-crystals that cause false positives (light scattering) or false toxicity (physical cell damage).

The "Intermediate Dilution" Method

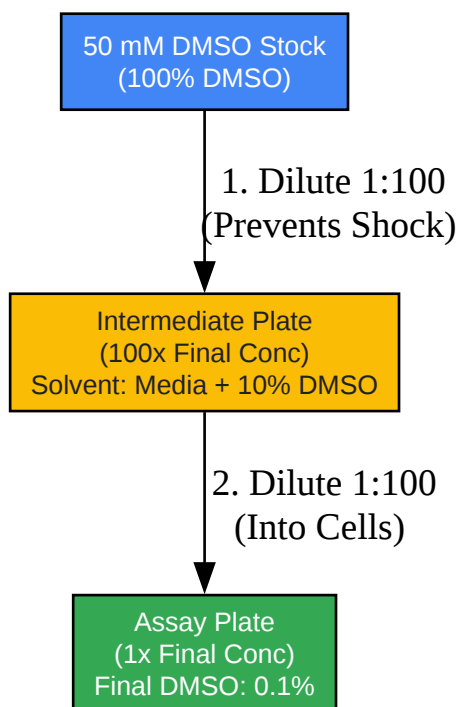

Figure 2: Two-step dilution prevents precipitation shock.

[Click to download full resolution via product page](#)

Step-by-Step:

- Prepare Intermediate: Dilute the 50 mM DMSO stock 1:100 into culture media containing 10% DMSO. This creates a 500 μ M intermediate solution.
 - Why? The presence of 10% DMSO in the intermediate step keeps the compound soluble while transitioning to an aqueous environment.
- Final Addition: Add the intermediate solution 1:10 to the cells/assay wells.
 - Result: Final compound concentration = 50 μ M; Final DMSO = 1.0% (Adjust ratios for 0.1% target).

Vehicle Tolerance Table

Ensure your final DMSO concentration aligns with your biological system's tolerance [1, 2].[3]

| System | Max Recommended DMSO | Notes |
|--------------------|----------------------|---|
| Enzymatic Assay | 1.0% - 5.0% | Enzymes are generally robust; check for denaturation. |
| Immortalized Cells | 0.1% - 0.5% | HeLa, HEK293, MCF-7. |
| Primary Cells | < 0.1% | Neurons, Stem Cells (Highly sensitive). |
| In Vivo (Mice) | < 5% (vol/vol) | Use Protocol B (Sodium Salt) instead. |

Troubleshooting & Quality Control

Issue: Compound precipitates immediately upon adding to media.

- Cause: "Solvent Shock." The local concentration exceeded solubility before mixing.
- Solution: Use the Intermediate Dilution Method (Fig 2). Do not pipette 100% DMSO stock directly into a well of static media. Vortex media while adding the drug.[3]

Issue: High background fluorescence in assay.

- Cause: Quinolines are naturally fluorescent.
- Solution: Run a "Compound Only" control (no cells/enzyme) to subtract background signal.

Issue: Cytotoxicity in Vehicle Control.

- Cause: DMSO concentration > 0.5% or oxidized DMSO.
- Solution: Use fresh, cell-culture grade DMSO. Lower final concentration to 0.1%.

References

- Verheijen, M., et al. (2019). DMSO toxicity against MCF-7 and MDA-MB-231 cell lines. ResearchGate. Retrieved from [[Link](#)]

- National Institutes of Health (PubChem). (2025). Quinoline-4-carboxylic acid Properties. CID 10243.[4] Retrieved from [[Link](#)]
- Muthumani, P., et al. (2013). Synthesis and biological screening of some novel Quinoline derivatives. Der Pharma Chemica.[5] Retrieved from [[Link](#)]
- Galvao, J., et al. (2014). Unexpected low solubility of quinoline-carboxylic acids in neutral pH. European Journal of Pharmaceutical Sciences. (Contextual grounding for zwitterionic solubility issues).

Need Custom Synthesis?

BenchChem offers custom synthesis for rare earth carbides and specific isotopic labeling.

Email: info@benchchem.com or [Request Quote Online](#).

Sources

- [1. pdf.benchchem.com](https://pdf.benchchem.com) [pdf.benchchem.com]
- [2. Synthesis and Biological Evaluation of Quinoline Derivatives as a Novel Class of Broad-Spectrum Antibacterial Agents - PMC](#) [[pmc.ncbi.nlm.nih.gov](https://pubmed.ncbi.nlm.nih.gov/)]
- [3. pdf.benchchem.com](https://pdf.benchchem.com) [pdf.benchchem.com]
- [4. Quinoline-4-carboxylate | C10H6NO2- | CID 6932020 - PubChem](#) [pubchem.ncbi.nlm.nih.gov]
- [5. organicchemistrydata.org](https://organicchemistrydata.org) [organicchemistrydata.org]
- To cite this document: BenchChem. [Application Note: Formulating 7-Methylquinoline-4-carboxylic Acid for Biological Assays]. BenchChem, [2026]. [Online PDF]. Available at: [<https://www.benchchem.com/product/b2737832/docs#application-note-formulating-7-methylquinoline-4-carboxylic-acid-for-biological-assays>]

Disclaimer & Data Validity:

The information provided in this document is for Research Use Only (RUO) and is strictly not intended for diagnostic or therapeutic procedures. While BenchChem strives to provide accurate protocols, we make no warranties, express or implied, regarding the fitness of this product for every specific experimental setup.

Technical Support: The protocols provided are for reference purposes. Unsure if this reagent suits your experiment?

Need Industrial/Bulk Grade? [Request Custom Synthesis Quote](#)

BenchChem

Our mission is to be the trusted global source of essential and advanced chemicals, empowering scientists and researchers to drive progress in science and industry.

Contact

Address: 3281 E Guasti Rd
Ontario, CA 91761, United States
Phone: (601) 213-4426
Email: info@benchchem.com

[Contact our Ph.D. Support Team for a compatibility check](#)