

# Comparative Guide: NMR Analysis of 3-Chloro-4,5-difluorobenzonitrile

**Author:** BenchChem Technical Support Team. **Date:** February 2026

## Compound of Interest

Compound Name: 3-Chloro-4,5-difluorobenzonitrile

CAS No.: 103879-29-4

Cat. No.: B2736653

[Get Quote](#)

## Executive Summary & Application Context

**3-Chloro-4,5-difluorobenzonitrile** is a high-value intermediate in the synthesis of agrochemicals and pharmaceuticals (e.g., fluoro-quinolone antibiotics, herbicides). Its structural integrity is defined by the specific arrangement of the chlorine atom relative to the fluorine atoms.

In synthetic workflows, this compound is often derived from 3,4,5-trifluorobenzonitrile or 3,4-dichloro-5-fluorobenzonitrile. Distinguishing the product from these starting materials relies heavily on NMR spectroscopy, specifically the loss of symmetry in the proton signals and the emergence of distinct fluorine environments.

## Key Differentiators

Feature	3-Chloro-4,5-difluorobenzonitrile (Target)	3,4,5-Trifluorobenzonitrile (Reference)
Symmetry	Asymmetric ( )	Symmetric ( )
<sup>1</sup> H Signals	2 distinct signals (H2 and H6)	1 signal (2H, equivalent)
<sup>19</sup> F Signals	2 distinct signals (F4 and F5)	2 signals (1F and 2F, integral ratio 1:2)
Coupling	Complex second-order effects; distinct	A X or AM spin system

## <sup>1</sup>H NMR Spectrum Analysis

### Theoretical Basis & Assignments

The proton spectrum is the primary tool for confirming the regiochemistry of the chlorine substitution.

- H2 (Position 2): Located between the cyano group (CN) and the chlorine (Cl). It is meta to F4 and para to F5.
- H6 (Position 6): Located between the cyano group (CN) and the fluorine (F5). It is ortho to F5 and meta to F4.

### Spectral Comparison

Parameter	3-Chloro-4,5-difluorobenzonitrile	3,4,5-Trifluorobenzonitrile
Chemical Shift ( )	H2: ~7.45 - 7.55 ppm H6: ~7.35 - 7.45 ppm	H2,6: ~7.40 - 7.50 ppm
Multiplicity	H2: Doublet of Doublets (dd) or broad singlet H6: Doublet of Doublets (dd)	H2,6: Doublet of Doublets (dd) (appearing as triplet-like)
Coupling Constants ( )	H2: Hz; HzH6: Hz; Hz	Hz (averaged due to symmetry)



*Analyst Note: The diagnostic feature of the target molecule is the H6 proton. Because it is ortho to a fluorine (F5), it exhibits a large coupling constant (*

*Hz). The H2 proton, being meta to the nearest fluorine, shows a significantly smaller coupling (*

*Hz). In the symmetric reference compound, both protons are identical and show identical splitting patterns.*

## Visualization of Splitting Logic

The following diagram illustrates the coupling tree for the H6 proton in the target molecule, highlighting the large ortho-Fluorine coupling.

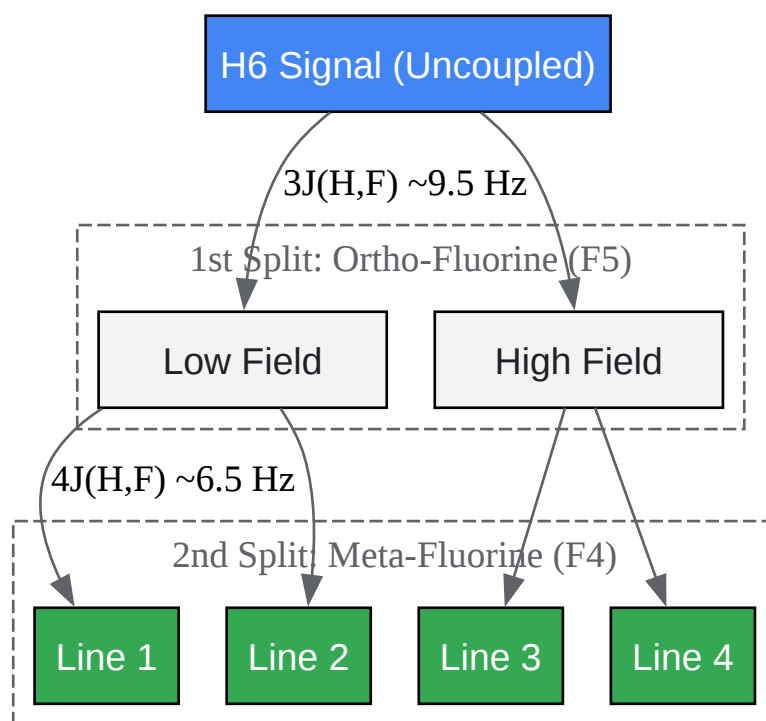

[Click to download full resolution via product page](#)

Caption: Splitting tree for Proton H6. The large ortho-coupling (3J) creates a wide doublet, which is further split by the meta-fluorine (4J) into a doublet of doublets.

## 19F NMR Spectrum Analysis

### Theoretical Basis

<sup>19</sup>F NMR is the most definitive method for characterizing this molecule due to the high sensitivity of fluorine chemical shifts to the local electronic environment.

- F4: Adjacent to Chlorine (Cl) and Fluorine (F5).
- F5: Adjacent to Hydrogen (H6) and Fluorine (F4).

### Spectral Comparison

Parameter	3-Chloro-4,5-difluorobenzonitrile	3,4,5-Trifluorobenzonitrile
Chemical Shift ( )	F4: ~ -130 to -135 ppm (Deshielded by Cl) F5: ~ -140 to -145 ppm	F4 (center): ~ -154 ppm F3,5 (sides): ~ -133 ppm
Integral Ratio	1 : 1	1 : 2 (Center : Sides)
Coupling Pattern	F4: ddd (Coupled to F5, H2, H6) F5: ddd (Coupled to F4, H6, H2)	F4: Triplet ( ) F3,5: Doublet ( )
Key Coupling ( )	Hz	Hz



*Critical Insight: The substitution of one fluorine (at pos 3) with chlorine causes a significant deshielding of the adjacent fluorine (F4) compared to the central fluorine in the trifluoro-precursor. Furthermore, the integration ratio changes from 1:2 (in the precursor) to 1:1 (in the target), providing an instant "Go/No-Go" QC check.*

## Experimental Protocols

### Standard Acquisition Parameters

To ensure reproducible data for regulatory or publication purposes, follow these acquisition parameters.

Sample Preparation:

- Solvent: Dissolve 10-15 mg of sample in 0.6 mL of CDCl<sub>3</sub> (Chloroform-d) or DMSO-d<sub>6</sub>.

- Note: DMSO-d6 may cause slight chemical shift variations due to hydrogen bonding with the CN group.
- Tube: Use high-quality 5mm NMR tubes (Wilmad 507-PP or equivalent) to minimize shimming errors.

Instrument Settings (400 MHz equivalent):

Parameter	<sup>1</sup> H NMR Protocol	<sup>19</sup> F NMR Protocol
Pulse Sequence	zg30 (30° pulse)	zg30 or zgig (Inverse Gated)
Sweep Width	12-14 ppm	200-300 ppm
Relaxation Delay (D1)	1.0 - 2.0 sec	2.0 - 5.0 sec (Ensure > 5T1)
Scans (NS)	16 - 64	32 - 128
Referencing	TMS (0.00 ppm) or Residual CHCl <sub>3</sub> (7.26 ppm)	CFCI <sub>3</sub> (0.00 ppm) or C <sub>6</sub> F <sub>6</sub> (-164.9 ppm)

\*Use Inverse Gated Decoupling (zgig) for <sup>19</sup>F if accurate integration is required to suppress the Nuclear Overhauser Effect (NOE).

## Workflow: Structural Verification

The following Graphviz diagram outlines the logical workflow for verifying the product identity using NMR data.

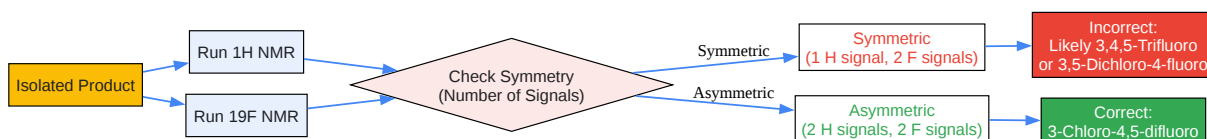

[Click to download full resolution via product page](#)

Caption: Logic flow for distinguishing the target compound from symmetric precursors/byproducts.

## References

- National Institute of Standards and Technology (NIST). 19F NMR Chemical Shifts of Fluorinated Aromatics. NIST Chemistry WebBook. Available at: [\[Link\]](#)
- Reich, H. J. Hans Reich's Collection: NMR Spectroscopy - 19F Chemical Shifts. University of Wisconsin-Madison. [\[1\]](#) Available at: [\[Link\]](#)
- Dolbier, W. R. Guide to Fluorine NMR for Organic Chemists. Wiley, 2009. (Standard text for coupling constants).

### Need Custom Synthesis?

BenchChem offers custom synthesis for rare earth carbides and specific isotopic labeling.

Email: [info@benchchem.com](mailto:info@benchchem.com) or [Request Quote Online](#).

## Sources

- [1. organicchemistrydata.org](https://www.organicchemistrydata.org) [[organicchemistrydata.org](https://www.organicchemistrydata.org)]
- To cite this document: BenchChem. [Comparative Guide: NMR Analysis of 3-Chloro-4,5-difluorobenzonitrile]. BenchChem, [2026]. [Online PDF]. Available at: [\[https://www.benchchem.com/product/b2736653#1h-and-19f-nmr-spectra-analysis-of-3-chloro-4-5-difluorobenzonitrile\]](https://www.benchchem.com/product/b2736653#1h-and-19f-nmr-spectra-analysis-of-3-chloro-4-5-difluorobenzonitrile)

### Disclaimer & Data Validity:

The information provided in this document is for Research Use Only (RUO) and is strictly not intended for diagnostic or therapeutic procedures. While BenchChem strives to provide accurate protocols, we make no warranties, express or implied, regarding the fitness of this product for every specific experimental setup.

**Technical Support:** The protocols provided are for reference purposes. Unsure if this reagent suits your experiment? [\[Contact our Ph.D. Support Team for a compatibility check\]](#)

**Need Industrial/Bulk Grade?** [Request Custom Synthesis Quote](#)

## BenchChem

Our mission is to be the trusted global source of essential and advanced chemicals, empowering scientists and researchers to drive progress in science and industry.

### Contact

Address: 3281 E Guasti Rd  
Ontario, CA 91761, United States  
Phone: (601) 213-4426  
Email: [info@benchchem.com](mailto:info@benchchem.com)