

Technical Support Center: Troubleshooting BrettPhos Pd G4 Reactions

Author: BenchChem Technical Support Team. **Date:** May 2026

Compound of Interest

Compound Name: *BrettPhosPdG4*

CAS No.: *1599466-83-7*

Cat. No.: *B2733968*

[Get Quote](#)

Topic: Troubleshooting Low Conversion Rates in BrettPhos Pd G4 Cross-Couplings Audience: Medicinal Chemists, Process Chemists, and Academic Researchers Content Type: Technical Guide & FAQ

System Overview & Mechanistic Grounding

BrettPhos Pd G4 (Generation 4) is a state-of-the-art palladium precatalyst designed for the formation of C–N bonds, particularly with primary amines.^[1] Unlike earlier generations, the G4 scaffold features a methylated amino group on the biphenyl backbone.^{[2][3]} Upon activation, this releases N-methylcarbazole rather than carbazole (a potential inhibitor and genotoxin), ensuring higher catalyst longevity and cleaner reaction profiles [1, 2].^[1]

The Critical Insight: Rate-Limiting Step

To troubleshoot effectively, you must understand the kinetics. For BrettPhos systems, the rate-limiting step is typically Oxidative Addition (OA) [3].^{[1][4]}

- Implication: The bulky BrettPhos ligand creates a crowded Pd center. While this promotes reductive elimination (forming the product), it makes the initial attack on the aryl halide

difficult.

- Troubleshooting Logic: If conversion is low, your system likely lacks the energy or electronic bias to break the Ar–X bond.

Catalyst Activation Pathway

The G4 precatalyst must undergo deprotonation and reductive elimination to enter the catalytic cycle. Failure here results in 0% conversion.

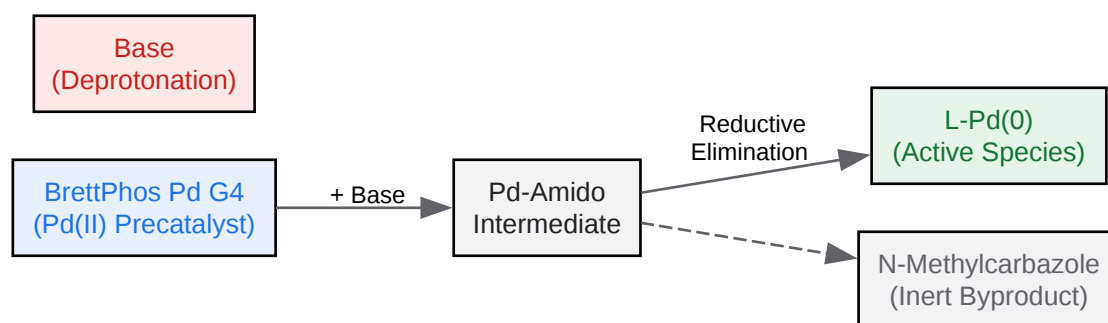

[Click to download full resolution via product page](#)

Figure 1: Activation pathway of BrettPhos Pd G4.[1] The precatalyst requires base to generate the active L-Pd(0) species in situ.[1][5]

Diagnostic Troubleshooting (Q&A)

Scenario A: Reaction never started (0% Conversion)

Q: I see no product and the aryl halide is untouched. Is the catalyst dead? A: It is more likely that the catalyst never activated.

- Root Cause: The G4 precatalyst requires a base to deprotonate the backbone amine. If your reaction uses a weak base (e.g., K_2CO_3) in an anhydrous, non-polar solvent (e.g., Toluene), the base may be too insoluble to initiate activation.[1]
- Solution:
 - Add a "Kickstarter": Add 1-2% water or use a catalytic amount of a soluble base (e.g., DBU) to initiate the cycle.[1]

- Switch Base: Move to NaOtBu or Cs₂CO₃.
- Check Lewis Basicity: If your substrate is a strong Lewis base (e.g., pyridine-rich), it may bind to the Pd(II) precatalyst and prevent the conformational change required for activation.^[1]

Q: The reaction mixture turned black immediately. What happened? A: "Pd Black" formation indicates rapid catalyst decomposition (agglomeration of Pd(0)).^[1]

- Root Cause: The active Pd(0) species was generated but had no aryl halide to react with (Oxidative Addition failed), or the ligand dissociated.
- Solution: Ensure the aryl halide is added before the catalyst and base. If using BrettPhos (bulky), the OA step is slow; consider increasing temperature to drive the OA step before the catalyst aggregates.

Scenario B: Reaction stalls (Partial Conversion)

Q: The reaction went to 50% conversion and stopped. Adding more catalyst didn't help. A: You are likely facing Product Inhibition or Poisoning.^[1]

- Root Cause: In Buchwald-Hartwig aminations, the amine product can sometimes bind to the metal. However, with BrettPhos, a common culprit is Iodide Inhibition. If you are using an Aryl Iodide, the released I⁻ ions can bridge Pd centers, forming inactive dimers [4].
- Solution:
 - Switch Halides: Use Aryl Bromides or Chlorides. Paradoxically, they are often faster than Iodides in these systems because they do not cause inhibition.
 - Solvent Swap: Switch to a solvent that solvates ions better (e.g., t-Amyl alcohol or Dioxane) to keep the halide sequestered.^[1]

Q: I am using a secondary amine and yields are low. Is BrettPhos the wrong choice? A: Likely, yes.

- Scientific Rationale: BrettPhos is optimized for Primary Amines.^{[1][6]} Its extreme bulk facilitates the coupling of smaller primary amines but can sterically hinder the approach of

secondary amines.

- Solution: Switch to RuPhos Pd G4. RuPhos is less sterically demanding in the specific quadrant required for secondary amine binding [3].

Optimization Matrix

Use this table to select conditions based on your specific failure mode.

Variable	Standard Condition	Optimization for Low Conversion	Why?
Solvent	1,4-Dioxane	t-Amyl Alcohol or Toluene	Alcohols can assist in proton transfer steps; Toluene is better for highly non-polar substrates.[1]
Base	NaOtBu (Strong)	K ₃ PO ₄ or Cs ₂ CO ₃	If functional groups are sensitive.[1] Note: Weak bases require higher temps (80°C+) to activate G4 efficiently.[1]
Temp	80°C	100°C - 110°C	BrettPhos systems are thermally stable. [1] Higher T overcomes the Oxidative Addition barrier (the rate-limiting step).[1]
Concentration	0.1 - 0.2 M	0.5 M	Higher concentration increases the rate of bimolecular steps (OA and Transmetallation). [1]
Additives	None	Water (0.1 equiv)	Trace water helps solubilize inorganic bases (Cs ₂ CO ₃ , K ₃ PO ₄), crucial for catalyst activation.[1]

Visual Troubleshooting Logic

Follow this decision tree to diagnose your specific issue.

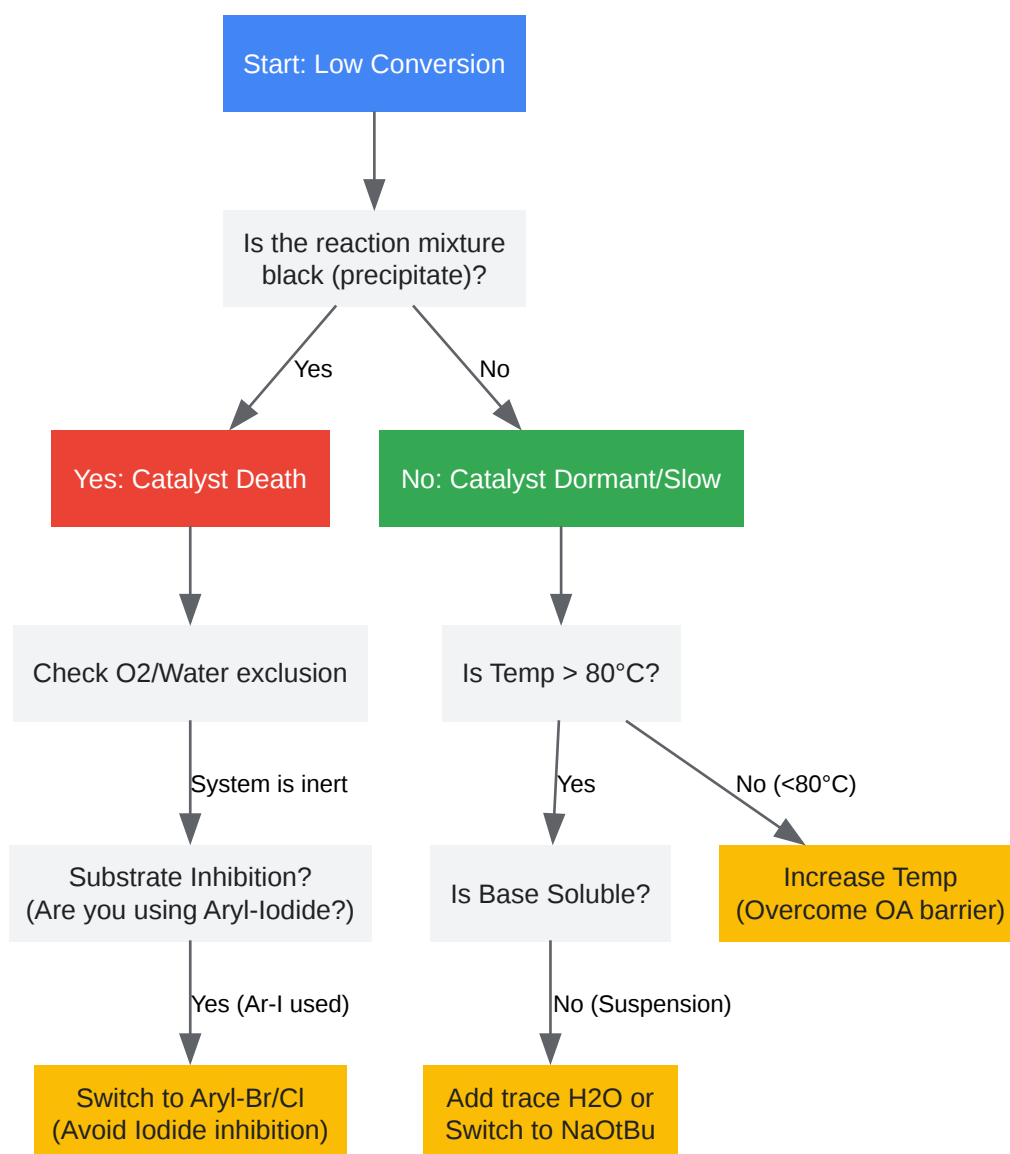

[Click to download full resolution via product page](#)

Figure 2: Decision tree for diagnosing low conversion in BrettPhos Pd G4 reactions.

Standardized Protocol (High-Fidelity)

To minimize variables, use this protocol for benchmarking before optimization.

Reagents:

- Aryl Halide (1.0 equiv)[1]
- Primary Amine (1.2 equiv)[1]

- BrettPhos Pd G4 (0.01 - 0.05 equiv / 1-5 mol%)[1]
- NaOtBu (1.4 equiv)[1]
- 1,4-Dioxane (anhydrous, 0.2 M concentration)[1]

Step-by-Step:

- Solid Addition: Charge a reaction vial with BrettPhos Pd G4, NaOtBu, and (if solid) the aryl halide and amine.
- Inerting: Seal the vial and purge with Nitrogen/Argon for 5 minutes. Note: G4 is air-stable, but the active species generated post-base addition is not.[1]
- Liquid Addition: Add anhydrous Dioxane and (if liquid) the amine/halide via syringe.
- Activation: Place in a pre-heated block at 100°C.
 - Why 100°C? BrettPhos is bulky.[5] High thermal energy ensures the precatalyst activates rapidly and the difficult oxidative addition step proceeds [1].
- Monitoring: Monitor by LCMS at 1 hour. If <10% conversion, refer to the Troubleshooting Tree above.

References

- Bruno, N. C., Niljianskul, N., & Buchwald, S. L. (2014). Design and Preparation of New Palladium Precatalysts for C–C and C–N Cross-Coupling Reactions. *Chemical Science*, 5(4), 1320-1324.[1] [Link](#)
- Sigma-Aldrich.[1][7] (n.d.). BrettPhos Pd G4 Product Information. Merck Millipore. [Link](#)
- Ruiz-Castillo, P., & Buchwald, S. L. (2016).[1] Applications of Palladium-Catalyzed C–N Cross-Coupling Reactions. *Chemical Reviews*, 116(19), 12564–12649.[1] [Link](#)[1]
- Ingoglia, B. T., & Buchwald, S. L. (2015). Oxidative Addition Complexes as Precatalysts for Cross-Coupling Reactions. *Organic Letters*, 17(11), 2680–2683.[1] [Link](#)[1]

Need Custom Synthesis?

BenchChem offers custom synthesis for rare earth carbides and specific isotopic labeling.

Email: info@benchchem.com or [Request Quote Online](#).

Sources

- 1. 95%, powder | Sigma-Aldrich [sigmaaldrich.com]
- 2. G3 and G4 Buchwald Precatalysts [sigmaaldrich.com]
- 3. scientificlabs.co.uk [scientificlabs.co.uk]
- 4. Ligand Effects of BrettPhos and RuPhos on Rate-Limiting Steps in Buchwald–Hartwig Amination Reaction Due to the Modulation of Steric Hindrance and Electronic Structure - PMC [pubmed.ncbi.nlm.nih.gov]
- 5. G3和G4 Buchwald预催化劑 [sigmaaldrich.com]
- 6. pdf.benchchem.com [pdf.benchchem.com]
- 7. Design and Preparation of New Palladium Precatalysts for C-C and C-N Cross-Coupling Reactions - PMC [pubmed.ncbi.nlm.nih.gov]
- To cite this document: BenchChem. [Technical Support Center: Troubleshooting BrettPhos Pd G4 Reactions]. BenchChem, [2026]. [Online PDF]. Available at: [<https://www.benchchem.com/product/b2733968/docs#technical-support-center-troubleshooting-brettphos-pd-g4-reactions>]

Disclaimer & Data Validity:

The information provided in this document is for Research Use Only (RUO) and is strictly not intended for diagnostic or therapeutic procedures. While BenchChem strives to provide accurate protocols, we make no warranties, express or implied, regarding the fitness of this product for every specific experimental setup.

Technical Support: The protocols provided are for reference purposes. Unsure if this reagent suits your experiment?

Need Industrial/Bulk Grade? [Request Custom Synthesis Quote](#)

BenchChem

Our mission is to be the trusted global source of essential and advanced chemicals, empowering scientists and researchers to drive progress in science and industry.

Contact

Address: 3281 E Guasti Rd

Ontario, CA 91761, United States

Phone: (601) 213-4426

Email: info@benchchem.com

[Contact our Ph.D. Support Team for a compatibility check](#)