

# Application Note: Palladium-Catalyzed Cross-Coupling Protocols with 2-Iodoanilines

**Author:** BenchChem Technical Support Team. **Date:** April 2026

## Compound of Interest

Compound Name: *N-Ethyl-2-iodoaniline;hydrochloride*

CAS No.: 2416231-71-3

Cat. No.: B2724199

[Get Quote](#)

## Strategic Overview: The 2-Iodoaniline Advantage

In drug discovery, 2-iodoaniline is a "privileged scaffold."<sup>[1]</sup> Its utility stems from the orthogonal reactivity of its two functional groups: the high-lability iodide (

) and the nucleophilic amine (

).

While the iodide undergoes rapid oxidative addition with Palladium(0), the adjacent amine offers a handle for spontaneous intramolecular cyclization. This unique "ortho-effect" allows researchers to access complex indole, quinoline, and carbazole cores—structures ubiquitous in therapeutics like Sumatriptan (migraine) and Sunitinib (oncology)—often in a single pot.

## Critical Challenges

Working with free 2-iodoanilines presents specific challenges that this guide addresses:

- Catalyst Poisoning: The free

group can coordinate to electrophilic Pd(II) species, arresting the catalytic cycle.

- **Regioselectivity:** In alkyne insertions (Larock), controlling the orientation of the incoming alkyne is non-trivial.
- **Oxidative Instability:** Anilines are prone to oxidation; protocols must ensure strict exclusion of oxygen unless specifically required for turnover.

## Protocol A: The Larock Indole Synthesis

Target: 2,3-Disubstituted Indoles Mechanism: Heteroannulation via Alkyne Insertion

The Larock synthesis is the gold standard for converting 2-iodoanilines into indoles. Unlike the Fischer indole synthesis, it proceeds under neutral/basic conditions and tolerates sensitive functional groups.

### Mechanistic Insight & Visualization

The reaction relies on the in situ generation of a chloride-ligated palladium species. The addition of Lithium Chloride (LiCl) is not optional; it is the critical factor that facilitates the displacement of the iodide and ensures the proper regioselectivity during the migratory insertion of the alkyne.

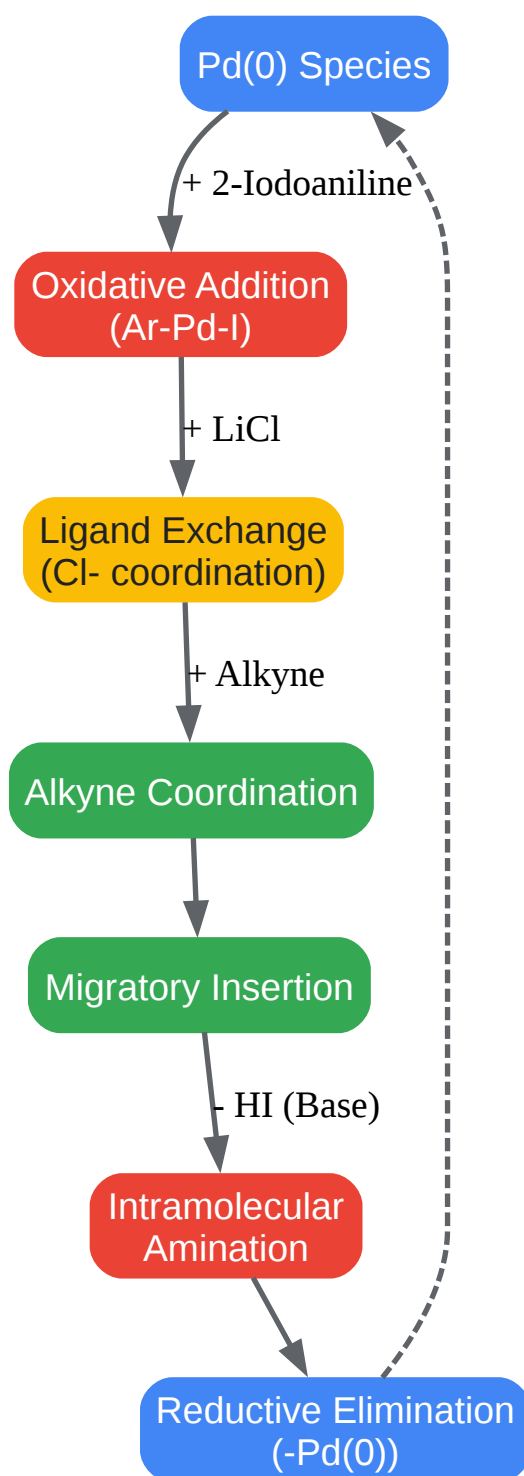

[Click to download full resolution via product page](#)

Figure 1: The catalytic cycle emphasizes the role of Chloride ions (from LiCl) in stabilizing the intermediate and directing alkyne insertion.

## Detailed Protocol

### Reagents:

- 2-Iodoaniline (1.0 equiv)[1][2]
- Internal Alkyne (1.2 equiv)
- (5 mol%)[1]
- or  
(3.0 equiv)
- LiCl (1.0 equiv) — CRITICAL ADDITIVE
- DMF (anhydrous, 0.2 M concentration)

### Step-by-Step:

- Catalyst Pre-loading: In a dry Schlenk tube equipped with a stir bar, combine (5 mol%), (3.0 equiv), and LiCl (1.0 equiv).
- Substrate Addition: Add 2-iodoaniline (1.0 equiv) and the internal alkyne (1.2 equiv).
- Solvation: Evacuate and backfill with Argon (3x). Add anhydrous DMF via syringe.
- Reaction: Heat the sealed vessel to 100 °C for 12–24 hours.
  - Note: The mixture will turn black as Pd(0) precipitates upon completion.
- Workup: Cool to room temperature. Dilute with diethyl ether and wash 3x with water (to remove DMF). Dry organic layer over , concentrate, and purify via flash chromatography.

Why this works: The bulky internal alkyne inserts such that the larger group ends up at the C2 position of the indole (steric control), while LiCl promotes the catalytic turnover.

## Protocol B: Sonogashira Coupling & Cacchi Cyclization

Target: 2-Substituted Indoles (from Terminal Alkynes) Mechanism: Copper-Cocatalyzed Alkynylation followed by Cyclization[1]

While Larock is ideal for internal alkynes, terminal alkynes require a Sonogashira approach. This can be performed as a one-pot, two-step sequence (The Cacchi Reaction).

### Experimental Workflow

Reagents:

- 2-Iodoaniline (1.0 equiv)[1][2]
- Terminal Alkyne (1.2 equiv)
- (2–3 mol%)
- CuI (1–2 mol%) — Required for terminal alkynes
- Triethylamine ( ) (Solvent/Base mixture)

Step-by-Step:

- Coupling (Step 1): Combine 2-iodoaniline, , and CuI in a flask. Add degassed (or /DMF 1:1). Add the terminal alkyne dropwise. Stir at RT to 40 °C for 2–4 hours.

- Checkpoint: Monitor TLC for the disappearance of 2-iodoaniline.[1] You now have the intermediate 2-alkynylaniline.[1]
- Cyclization (Step 2):
  - Method A (Thermal): Simply heat the reaction mixture to 80–100 °C. The amine attacks the activated alkyne.
  - Method B (Lewis Acid - Faster): Add a catalytic amount of  $\text{CuI}$  or additional  $\text{CuI}$  and heat to 60 °C.
- Purification: Standard aqueous workup and silica chromatography.

Key Distinction: Unlike the Larock synthesis, the regiochemistry here is fixed by the terminal alkyne; the substituent always ends up at the C2 position.

## Protocol C: Suzuki-Miyaura Coupling

Target: 2-Arylanilines (Biaryl Scaffolds) Mechanism: Boronic Acid Cross-Coupling[2]

This protocol addresses the synthesis of biaryls, precursors to carbazoles. The challenge here is preventing the free amine from inhibiting the Palladium catalyst.

## Ligand Selection Strategy

Standard

often fails with free anilines because the amine competes for the Pd center. We utilize S-Phos or Buchwald Precatalysts which are bulky and electron-rich, preventing amine coordination and facilitating oxidative addition.

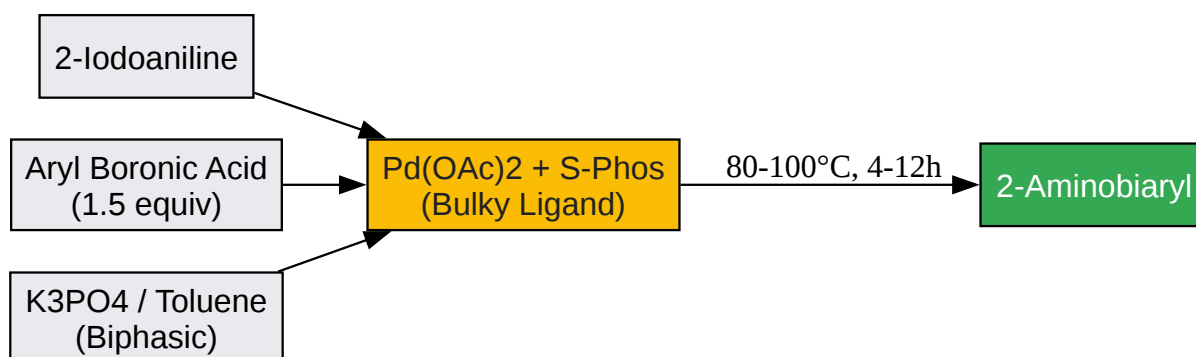

[Click to download full resolution via product page](#)

Figure 2: Workflow for Suzuki coupling of unprotected anilines.

Protocol:

- Setup: Charge a vial with 2-iodoaniline (1.0 equiv), Arylboronic acid (1.5 equiv), (2 mol%), and S-Phos (4 mol%).
- Base: Add (2.0 equiv).
- Solvent: Add Toluene/Water (10:1 ratio). The water is essential for the boronic acid activation.
- Reaction: Heat to 100 °C for 8 hours.
- Result: High yields of 2-aminobiaryls without N-arylation side products.

## Comparative Data & Troubleshooting

### Yield Comparison Table

Protocol	Substrate Scope	Typical Yield	Key Limiting Factor
Larock	Internal Alkynes	75–92%	Steric bulk of alkyne can slow reaction.
Sonogashira	Terminal Alkynes	80–95%	Homocoupling of alkyne (Glaser coupling).
Suzuki	Aryl Boronic Acids	85–98%	Protodeboronation of unstable boronic acids.

## Troubleshooting Guide

- Problem:Low conversion in Larock Synthesis.
  - Solution: Check your LiCl. It must be anhydrous.[3] If the reaction stalls, add 10% more catalyst and increase temp to 110 °C. Ensure the alkyne is not volatile.
- Problem:Homocoupling in Sonogashira (Alkyne-Alkyne).
  - Solution: This occurs if Oxygen is present. Degas solvents thoroughly (freeze-pump-thaw). Add the alkyne slowly (syringe pump) to keep its concentration low relative to the aryl iodide.
- Problem:Pd Black precipitation early in reaction.
  - Solution: The catalytic cycle is crashing. Increase ligand concentration (e.g., move from 1:2 to 1:4 Pd:Ligand ratio) or switch to a phosphine-free source like  
  
for simpler substrates.

## References

- Larock, R. C., & Yum, E. K. (1991). Synthesis of indoles via palladium-catalyzed heteroannulation of internal alkynes. *Journal of the American Chemical Society*.

- Sonogashira, K., Tohda, Y., & Hagihara, N. (1975). A convenient synthesis of acetylenes: catalytic substitutions of acetylenic hydrogen with bromoalkenes, iodoarenes and bromopyridines. *Tetrahedron Letters*.
- Cacchi, S., Fabrizi, G., & Parisi, L. (2005). Palladium-catalyzed synthesis of indoles from 2-alkynyltrifluoroacetanilides.[4] *Organic Letters*.
- Martin, R., & Buchwald, S. L. (2008). Palladium-catalyzed Suzuki-Miyaura cross-coupling reactions employing dialkylbiaryl phosphine ligands. *Accounts of Chemical Research*.
- Roesch, K. R., & Larock, R. C. (2001). Synthesis of isoquinolines and pyridines by the palladium-catalyzed iminoannulation of internal alkynes. *The Journal of Organic Chemistry*.

#### Need Custom Synthesis?

BenchChem offers custom synthesis for rare earth carbides and specific isotopic labeling.

Email: [info@benchchem.com](mailto:info@benchchem.com) or [Request Quote Online](#).

## Sources

- [1. pdf.benchchem.com \[pdf.benchchem.com\]](#)
- [2. pdf.benchchem.com \[pdf.benchchem.com\]](#)
- [3. Sonogashira Coupling \[organic-chemistry.org\]](#)
- [4. Preparation of 2,3-Disubstituted Indoles by Sequential Larock Heteroannulation and Silicon-Based Cross-Coupling Reactions - PMC \[pmc.ncbi.nlm.nih.gov\]](#)
- To cite this document: BenchChem. [Application Note: Palladium-Catalyzed Cross-Coupling Protocols with 2-Iodoanilines]. BenchChem, [2026]. [Online PDF]. Available at: [\[https://www.benchchem.com/product/b2724199/docs#application-note-palladium-catalyzed-cross-coupling-protocols-with-2-iodoanilines\]](https://www.benchchem.com/product/b2724199/docs#application-note-palladium-catalyzed-cross-coupling-protocols-with-2-iodoanilines)

---

#### Disclaimer & Data Validity:

The information provided in this document is for Research Use Only (RUO) and is strictly not intended for diagnostic or therapeutic procedures. While BenchChem strives to provide

accurate protocols, we make no warranties, express or implied, regarding the fitness of this product for every specific experimental setup.

**Technical Support:** The protocols provided are for reference purposes. Unsure if this reagent suits your experiment?

**Need Industrial/Bulk Grade?** [Request Custom Synthesis Quote](#)

## BenchChem

Our mission is to be the trusted global source of essential and advanced chemicals, empowering scientists and researchers to drive progress in science and industry.

### Contact

Address: 3281 E Guasti Rd

Ontario, CA 91761, United States

Phone: (601) 213-4426

Email: [info@benchchem.com](mailto:info@benchchem.com)

[Contact our Ph.D. Support Team for a compatibility check](#)