

# Technical Support Center: Storage and Handling of Light-Sensitive Iodoalkyne Intermediates

**Author:** BenchChem Technical Support Team. **Date:** March 2026

## Compound of Interest

Compound Name: 2-((6-Iodohex-2-yn-1-yl)oxy)tetrahydro-2H-pyran

CAS No.: 532414-06-5

Cat. No.: B2721619

[Get Quote](#)

Welcome to the technical support center for iodoalkyne intermediates. This guide is designed for researchers, scientists, and drug development professionals who work with these highly reactive and sensitive compounds. Iodoalkynes are powerful synthetic building blocks, but their utility is matched by their instability, particularly to light, heat, and oxygen. Improper storage can lead to decomposition, compromising experimental integrity and resulting in failed reactions.

This resource provides field-proven insights and troubleshooting protocols to ensure the long-term stability and purity of your iodoalkyne intermediates. The information is structured in a practical question-and-answer format to directly address the challenges you may encounter in the lab.

## Section 1: Troubleshooting Guide

This section addresses specific problems that may arise during the storage and handling of iodoalkyne intermediates.

**Question:** My iodoalkyne, which was initially a white or colorless solid/liquid, has developed a yellow or brown tint. What happened?

**Answer:** This discoloration is a classic indicator of decomposition.<sup>[1]</sup> The carbon-iodine (C-I) bond in iodoalkynes is susceptible to cleavage, especially when exposed to light (photolysis) or heat (thermolysis). This degradation process releases elemental iodine (I<sub>2</sub>), which imparts the

characteristic yellow-to-brown color.[1][2] The presence of oxygen or moisture can accelerate this process.[1][3]

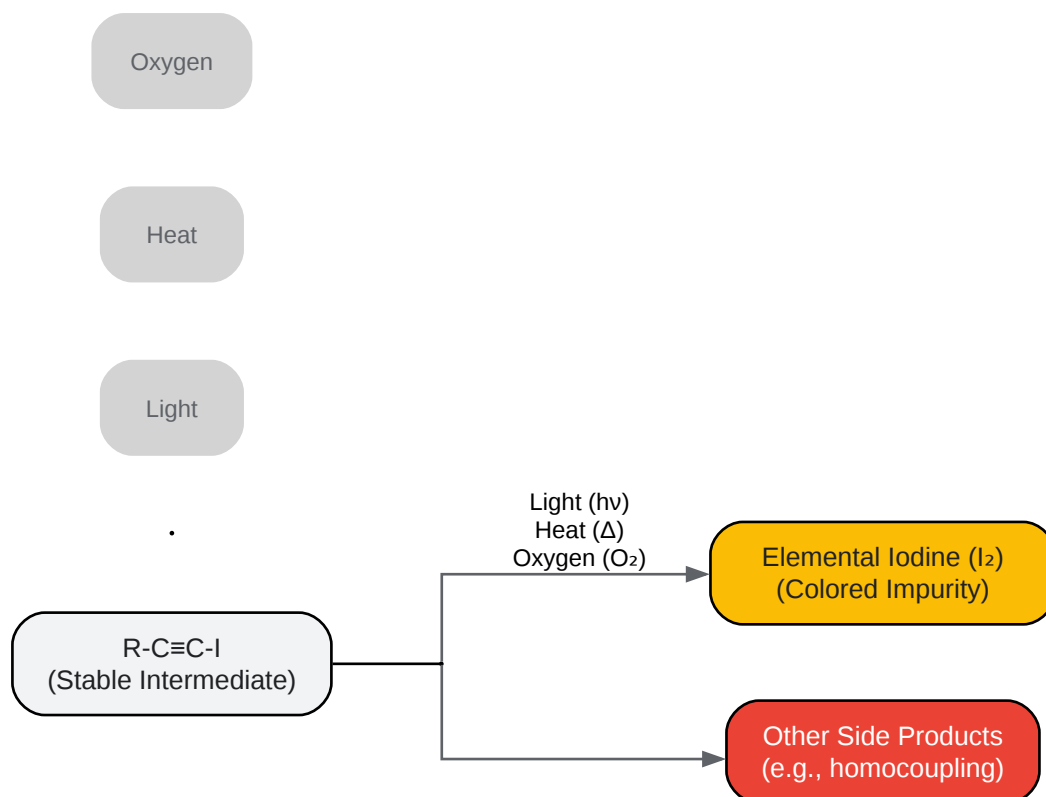

[Click to download full resolution via product page](#)

Caption: Iodoalkyne Degradation Pathway.

Question: My discolored iodoalkyne sample shows unexpected peaks in its  $^1H$  NMR or HPLC analysis. Can I still use it?

Answer: The appearance of new signals in NMR or additional peaks in an HPLC chromatogram confirms chemical degradation.[1] Whether the material is still usable depends on the extent of decomposition and the sensitivity of your downstream application.

Recommended Action Plan:

- **Quantify Impurities:** Use analytical techniques like quantitative NMR (qNMR) or HPLC with a reference standard to determine the percentage of the remaining active iodoalkyne.[4][5] For a less rigorous check, the relative integration of impurity peaks in  $^1\text{H}$  NMR can provide a rough estimate.[1]
- **Assess Fitness for Use:** If decomposition is minor (<5%) and the impurities are not expected to interfere with your reaction, you may proceed with caution. However, for sensitive applications like catalysis or final-step API synthesis, using a degraded intermediate is highly discouraged as it can lead to complex side reactions and purification challenges.[6]
- **Purification:** For minor decomposition where the primary impurity is elemental iodine, you may be able to purify the intermediate. A common method is to wash a solution of the compound with a dilute aqueous solution of sodium thiosulfate ( $\text{Na}_2\text{S}_2\text{O}_3$ ) to quench the  $\text{I}_2$ , followed by drying and removal of the solvent.[7] However, for significant degradation, resynthesis is often more practical.

Question: My reaction with a stored iodoalkyne is sluggish or failing, even though the material looks fine.

Answer: Even without visible discoloration, iodoalkynes can undergo degradation. The absence of color does not guarantee purity. The active concentration of your intermediate may be lower than expected due to the formation of non-colored byproducts or oligomerization.[8]

Troubleshooting Workflow:

- **Verify Storage Conditions:** Confirm that the compound was stored under the correct conditions (see Table 1 below). Accidental exposure to light or a freezer failure could be the cause.[9][10]
- **Perform a Quality Control Check:** Before running a large-scale reaction, always perform a quick purity check on stored intermediates. A simple TLC or a crude  $^1\text{H}$  NMR spectrum can be very informative.[8]
- **Use a Fresh Sample:** If possible, compare the reaction outcome with a freshly synthesized or newly purchased batch of the iodoalkyne. This will help determine if the stored material is the root cause of the issue.

## Section 2: Frequently Asked Questions (FAQs)

Q1: What are the ideal long-term storage conditions for solid iodoalkyne intermediates?

A1: The optimal conditions aim to mitigate exposure to light, heat, oxygen, and moisture.

Parameter	Recommendation	Rationale
Temperature	-20°C or below (Freezer)	Reduces thermal energy, slowing the rate of decomposition. <a href="#">[9]</a> <a href="#">[11]</a>
Atmosphere	Inert Gas (Argon or Nitrogen)	Prevents oxidation and degradation accelerated by oxygen and moisture. <a href="#">[3]</a> <a href="#">[10]</a>
Container	Amber Glass Vial or Foil-Wrapped Vial	Blocks UV and visible light, preventing photochemical reactions. <a href="#">[6]</a> <a href="#">[9]</a> <a href="#">[12]</a>
Seal	Tightly Sealed Cap with Parafilm®	Creates a physical barrier against atmospheric moisture and oxygen ingress. <a href="#">[8]</a>

Table 1: Recommended Long-Term Storage Conditions for Solid Iodoalkynes.

Q2: How should I store a stock solution of an iodoalkyne?

A2: Storing iodoalkynes in solution is generally not recommended for long periods as degradation can be faster than in the solid state. If a stock solution is necessary, prepare it fresh whenever possible.[\[6\]](#) For short- to medium-term storage (days to weeks), follow these guidelines:

- Use a Degassed Solvent: Remove dissolved oxygen from the solvent by sparging with argon or nitrogen.[\[6\]](#)
- Store in an Amber Vial: Use a vial specifically designed to block light.[\[9\]](#)[\[12\]](#)
- Store Cold and Dark: Store the solution at -20°C in a freezer.[\[6\]](#)

- Inert Atmosphere: Blanket the headspace of the vial with argon or nitrogen before sealing.  
[11]

Q3: Are there any chemical stabilizers I can add to my iodoalkyne?

A3: While some commercial iodoalkanes are sold with stabilizers like copper powder to scavenge free radicals, this is less common for iodoalkyne intermediates and can complicate downstream reactions. The most effective strategy is not to add stabilizers but to rigorously control the storage environment by excluding light, heat, and oxygen. In some specific applications, like perovskite precursor solutions, additives like sodium thiosulfate have been used to inhibit iodide oxidation.[13]

Q4: How should I handle iodoalkynes during an experiment to minimize degradation?

A4: Proper handling during weighing and reaction setup is as critical as long-term storage.

- Work in Subdued Light: Dim overhead lights and avoid direct sunlight. Use a yellow or red safelight if necessary, as longer wavelengths are less energetic.[6]
- Minimize Exposure: Weigh the compound quickly and add it to the reaction vessel promptly.  
[6]
- Protect Glassware: Wrap reaction flasks, separatory funnels, and chromatography columns with aluminum foil.[6][8][12]
- Maintain Inert Atmosphere: If the reaction is air-sensitive, use standard Schlenk line or glovebox techniques.[3]

## Section 3: Standard Operating Protocols

### Protocol 1: Preparing an Iodoalkyne for Long-Term Storage

Objective: To properly package a freshly synthesized or newly opened iodoalkyne intermediate for stable long-term storage.

Methodology:

- **Select the Right Container:** Choose a clean, dry amber glass vial with a screw cap that provides a tight seal.
- **Transfer the Compound:** In an environment with subdued light, transfer the solid iodoalkyne into the vial.
- **Purge with Inert Gas:** Gently flush the vial with a stream of dry argon or nitrogen for 15-30 seconds to displace air and moisture.[\[11\]](#)
- **Seal Tightly:** Immediately cap the vial. For extra protection, wrap the cap and neck of the vial with Parafilm®.
- **Label Clearly:** Label the vial with the compound name, structure, batch number, date, and storage conditions (e.g., "-20°C, Inert, Dark").[\[9\]](#)
- **Store Appropriately:** Place the vial inside a secondary container or a designated freezer box and store it in a freezer at -20°C or below.[\[9\]](#)[\[14\]](#)

## Protocol 2: Quality Control Check of a Stored Iodoalkyne via HPLC

Objective: To assess the purity of a stored iodoalkyne sample and detect degradation products.

Methodology:

- **Prepare a Standard:** If available, prepare a solution of a known-pure reference standard of the iodoalkyne at a defined concentration (e.g., 1 mg/mL).
- **Prepare the Sample:** Prepare a solution of the stored iodoalkyne at the same concentration as the standard.
- **HPLC Setup (Typical Conditions):**
  - **Instrumentation:** HPLC system with a UV detector.[\[4\]](#)
  - **Column:** C18 reverse-phase column (e.g., 4.6 x 250 mm, 5 µm).[\[4\]](#)
  - **Mobile Phase:** A gradient of acetonitrile and water is often a good starting point.

- Detection: Set the UV detector to a wavelength where the iodoalkyne has strong absorbance (e.g., 254 nm).[4]
- Analysis:
  - Inject the standard to determine its retention time and peak area.
  - Inject the stored sample.
  - Compare the chromatograms. Look for a decrease in the main peak area and the appearance of new peaks (often at different retention times) in the sample compared to the standard.[1]
- Purity Calculation: Calculate the purity by the area percentage method:  $\text{Purity (\%)} = (\text{Area of Main Peak} / \text{Total Area of All Peaks}) * 100$ . This provides a good estimate of chromatographic purity.[4][15]

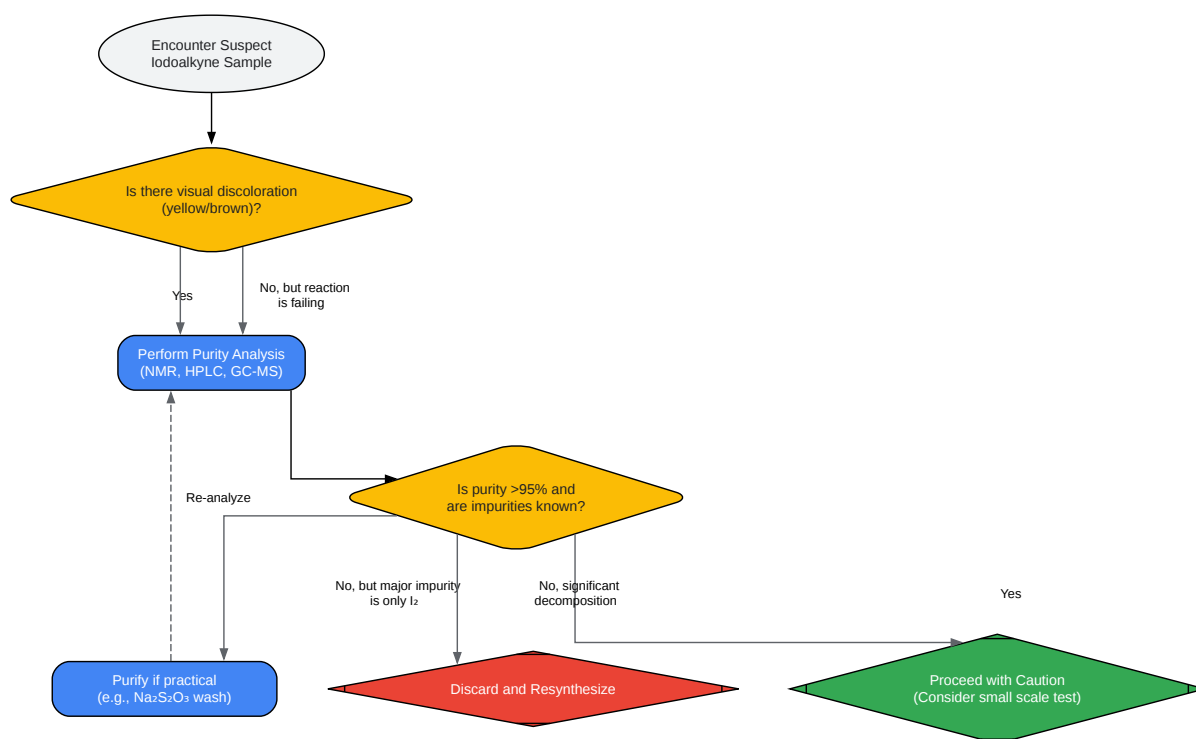

[Click to download full resolution via product page](#)

### Need Custom Synthesis?

BenchChem offers custom synthesis for rare earth carbides and specific isotopic labeling.

Email: [info@benchchem.com](mailto:info@benchchem.com) or [Request Quote Online](#).

## Sources

- [1. pdf.benchchem.com \[pdf.benchchem.com\]](https://pdf.benchchem.com)
- [2. Reactivity of Potassium Iodide Under Light - Allan Chemical Corporation | allanchem.com \[allanchem.com\]](https://allanchem.com)
- [3. ossila.com \[ossila.com\]](https://ossila.com)
- [4. pdf.benchchem.com \[pdf.benchchem.com\]](https://pdf.benchchem.com)
- [5. pdf.benchchem.com \[pdf.benchchem.com\]](https://pdf.benchchem.com)
- [6. benchchem.com \[benchchem.com\]](https://benchchem.com)
- [7. pubs.acs.org \[pubs.acs.org\]](https://pubs.acs.org)
- [8. How To \[chem.rochester.edu\]](https://chem.rochester.edu)
- [9. globalresearchchem.com \[globalresearchchem.com\]](https://globalresearchchem.com)
- [10. pdf.benchchem.com \[pdf.benchchem.com\]](https://pdf.benchchem.com)
- [11. lumiprobe.com \[lumiprobe.com\]](https://lumiprobe.com)
- [12. 5 Tips for Handling Photosensitive Reagents - Labtag Blog \[blog.labtag.com\]](https://blog.labtag.com)
- [13. Extending the shelf-life of precursor solutions and inhibiting light-induced oxidation of iodides for achieving highly efficient and durable perovskite solar cells - Journal of Materials Chemistry A \(RSC Publishing\) \[pubs.rsc.org\]](https://pubs.rsc.org)
- [14. camlab.co.uk \[camlab.co.uk\]](https://camlab.co.uk)
- [15. How to identified the purity of standard substance? - Chromatography Forum \[chromforum.org\]](https://chromforum.org)
- [To cite this document: BenchChem. \[Technical Support Center: Storage and Handling of Light-Sensitive Iodoalkyne Intermediates\]. BenchChem, \[2026\]. \[Online PDF\]. Available at: \[https://www.benchchem.com/product/b2721619#storage-conditions-for-light-sensitive-iodoalkyne-intermediates\]](https://www.benchchem.com/product/b2721619#storage-conditions-for-light-sensitive-iodoalkyne-intermediates)

---

### Disclaimer & Data Validity:

The information provided in this document is for Research Use Only (RUO) and is strictly not intended for diagnostic or therapeutic procedures. While BenchChem strives to provide accurate protocols, we make no warranties, express or implied, regarding the fitness of this product for every specific experimental setup.

**Technical Support:** The protocols provided are for reference purposes. Unsure if this reagent suits your experiment? [[Contact our Ph.D. Support Team for a compatibility check](#)]

**Need Industrial/Bulk Grade?** [Request Custom Synthesis Quote](#)

## BenchChem

Our mission is to be the trusted global source of essential and advanced chemicals, empowering scientists and researchers to drive progress in science and industry.

### Contact

Address: 3281 E Guasti Rd  
Ontario, CA 91761, United States  
Phone: (601) 213-4426  
Email: [info@benchchem.com](mailto:info@benchchem.com)