

Introduction: The Analytical Imperative for Complex Piperidine Derivatives

Author: BenchChem Technical Support Team. **Date:** May 2026

Compound of Interest

Compound Name: *[1,1'-Biphenyl]-3,4'-dicarbaldehyde*

CAS No.: 869959-13-7

Cat. No.: B2719025

[Get Quote](#)

In the landscape of modern drug discovery and development, piperidine scaffolds are ubiquitous, forming the core of numerous pharmacologically active agents.^[1] Their structural elucidation and the profiling of their related impurities are critical for ensuring safety and efficacy. The compound 1-Boc-4-(4-fluoro-N-methylbenzamido)piperidine (CAS 142695-43-4) is a key intermediate in the synthesis of various pharmaceutical compounds. A thorough understanding of its behavior under mass spectrometric analysis is paramount for researchers in process development, quality control, and metabolite identification.

This guide provides a comprehensive analysis of the predicted mass spectrometry fragmentation patterns of this molecule under both soft (Electrospray Ionization) and hard (Electron Ionization) ionization techniques. By dissecting the fragmentation pathways, we aim to provide a predictive framework for identifying this compound and its potential analogues, setting it apart from structurally similar molecules. This document is intended for researchers, scientists, and drug development professionals who require a deep, mechanistic understanding of mass spectrometry to support their work.

Molecular Structure and Predicted Fragmentation

Logic

The fragmentation of a molecule in a mass spectrometer is a predictable process governed by the stability of the resulting ions and neutral losses.[2] The structure of 1-Boc-4-(4-fluoro-N-methylbenzamido)piperidine contains several key features that will dictate its fragmentation: the bulky tert-butoxycarbonyl (Boc) protecting group, the central piperidine ring, a stable aromatic ring with an electronegative fluorine atom, and an amide linkage.

The stability of the carbocations formed during fragmentation is a primary driving force, with tertiary carbocations being more stable than secondary, which are more stable than primary.[2] [3] This principle will be central to predicting the most likely bond cleavages.

Electrospray Ionization (ESI-MS/MS) Fragmentation Pathway

Electrospray ionization is a soft ionization technique that typically results in the formation of a protonated molecule, $[M+H]^+$. [1] Subsequent tandem mass spectrometry (MS/MS) induces fragmentation through collision-induced dissociation (CID), revealing the molecule's structural backbone. For 1-Boc-4-(4-fluoro-N-methylbenzamido)piperidine, protonation is most likely to occur on the most basic sites: the piperidine nitrogen or the amide oxygen.

The key fragmentation pathways for the $[M+H]^+$ ion (m/z 351.2) are expected to be:

- **Loss of the Boc Group:** The tert-butyl group is prone to elimination as isobutylene (56 Da) via a rearrangement, a characteristic fragmentation for Boc-protected amines. This would result in a fragment ion at m/z 295.1. A subsequent loss of CO_2 (44 Da) could also occur, leading to a fragment at m/z 251.1.
- **Amide Bond Cleavage:** The amide bond can cleave to produce two characteristic ions:
 - The N-methyl-4-fluorobenzoyl iminium ion at m/z 152.1.
 - The protonated 1-Boc-4-aminopiperidine at m/z 201.2, which can further fragment by losing isobutylene to m/z 145.1.

- Piperidine Ring Fragmentation: While less common for the protonated molecule under typical CID energies, fragmentation of the piperidine ring itself can occur, often initiated by the protonated nitrogen.[4][5]

The most abundant fragments are likely to arise from the loss of the Boc group and the cleavage of the amide bond, as these pathways lead to stable, resonance-delocalized ions.

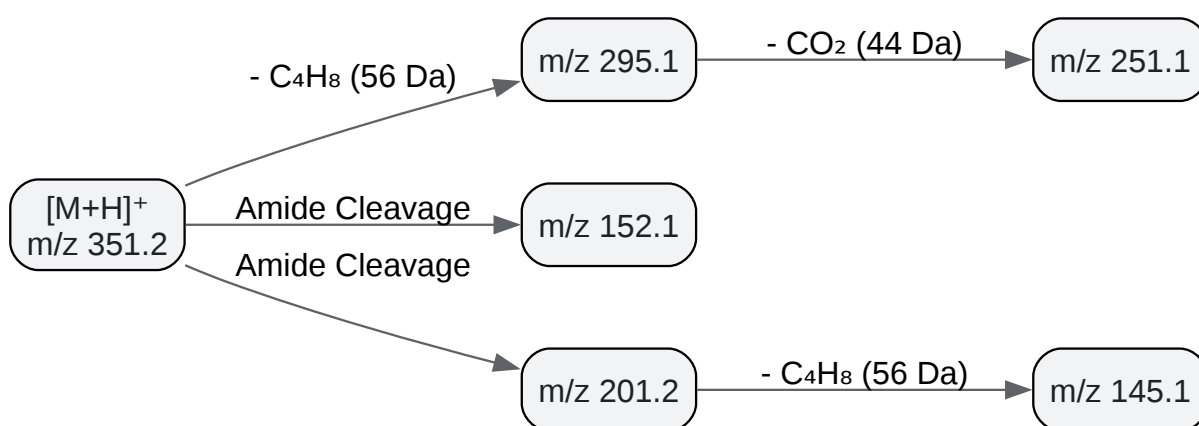

[Click to download full resolution via product page](#)

Caption: Predicted ESI-MS/MS fragmentation of CAS 142695-43-4.

Electron Ionization (EI) Fragmentation Pathway

Electron ionization is a high-energy technique that leads to extensive fragmentation and provides a detailed molecular fingerprint. The fragmentation is initiated by the removal of an electron to form a molecular ion ($M^{+\bullet}$).

Key EI fragmentation pathways include:

- α -Cleavage: This is a dominant fragmentation pathway for amines and piperidine derivatives. [1][6] Cleavage of the C-C bond adjacent to the nitrogen atom results in a stable iminium ion. For the piperidine ring in our molecule, this can lead to multiple fragment ions.
- Cleavage at Branching Points: C-C bonds at branching points are preferentially cleaved due to the formation of more stable carbocations.[3] The bond between the piperidine ring and the nitrogen of the amide group is a likely point of cleavage.

- Aromatic Fragmentation: The 4-fluorobenzoyl group can form a stable acylium ion at m/z 123.0. Aromatic rings themselves are quite stable and often appear as prominent ions.

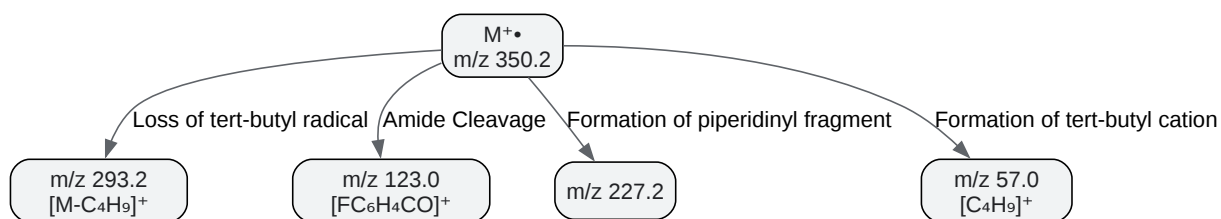

[Click to download full resolution via product page](#)

Caption: Predicted EI-MS fragmentation of CAS 142695-43-4.

Comparative Analysis

Comparison with an Unprotected Analogue

To highlight the influence of the Boc group, let's consider the fragmentation of the corresponding unprotected compound, 4-(4-fluoro-N-methylbenzamido)piperidine.

Feature	1-Boc-4-(4-fluoro-N-methylbenzamido)piperidine	4-(4-fluoro-N-methylbenzamido)piperidine
[M+H] ⁺	351.2	251.1
Key ESI Fragments	Loss of isobutylene (m/z 295.1), Amide cleavage fragments (m/z 152.1, 201.2)	Amide cleavage fragments (m/z 152.1, 101.1)
Diagnostic Feature	Neutral loss of 56 Da or 100 Da is highly indicative of the Boc group.	Absence of the Boc-related losses. The base peak would likely be the 4-fluorobenzoyl fragment.

This comparison demonstrates that the Boc group provides a clear diagnostic marker in the mass spectrum. Its absence would significantly alter the fragmentation pattern, making it straightforward to distinguish between the protected and unprotected forms.

Comparison with Alternative Analytical Techniques

While mass spectrometry is powerful for structural elucidation, other techniques offer complementary information.

Technique	Strengths for CAS 142695-43-4	Limitations
Mass Spectrometry (LC-MS)	High sensitivity and specificity. Provides molecular weight and structural information from fragmentation.[7] Ideal for identifying impurities.	Isomers may not be distinguishable without chromatographic separation.
Nuclear Magnetic Resonance (NMR)	Provides detailed information about the carbon-hydrogen framework and the connectivity of atoms. Unambiguous structure determination.	Lower sensitivity compared to MS. Requires a larger amount of pure sample.
High-Performance Liquid Chromatography (HPLC-UV)	Excellent for quantification and separation of mixtures.	Provides limited structural information. A reference standard is required for identification.

The choice of technique depends on the analytical goal. For identification and structural confirmation, a combination of LC-MS and NMR is the gold standard. For routine quantification and purity checks, HPLC-UV is often sufficient.

Experimental Protocols

The following protocols are provided as a starting point and should be optimized for the specific instrumentation and analytical requirements.

Protocol 1: LC-MS/MS Analysis

This method is suitable for the identification and quantification of CAS 142695-43-4 in complex matrices.

1. Sample Preparation: a. Accurately weigh 1 mg of the sample and dissolve in 1 mL of methanol to create a 1 mg/mL stock solution. b. Perform serial dilutions with 50:50 methanol:water to achieve the desired concentration (e.g., 1 µg/mL).

2. Chromatographic Conditions:

- Column: C18 reverse-phase column (e.g., 2.1 x 50 mm, 1.8 µm).
- Mobile Phase A: 0.1% formic acid in water.
- Mobile Phase B: 0.1% formic acid in acetonitrile.
- Gradient: Start at 10% B, ramp to 95% B over 5 minutes, hold for 2 minutes, and return to initial conditions.
- Flow Rate: 0.3 mL/min.[1]
- Column Temperature: 40 °C.[1]
- Injection Volume: 2 µL.

3. Mass Spectrometer Conditions (ESI Positive Mode):

- Ionization Mode: Positive Electrospray Ionization (ESI+).[1]
- Capillary Voltage: 3.5 kV.
- Source Temperature: 120 °C.
- Desolvation Temperature: 350 °C.
- Full Scan (MS1): Scan from m/z 100-500 to identify the [M+H]⁺ precursor ion.
- Product Ion Scan (MS/MS): Select the precursor ion (m/z 351.2) and apply a range of collision energies (e.g., 10-40 eV) to generate a comprehensive fragmentation spectrum.

```
Sample [label="Sample Preparation\n(Dissolution & Dilution)"]; HPLC [label="HPLC Separation\n(C18 Column)"]; ESI [label="Electrospray Ionization\n(Positive Mode)"]; MS1 [label="MS1 Scan\n(Precursor Ion Selection)"]; CID [label="Collision-Induced Dissociation"]; MS2 [label="MS2 Scan\n(Fragment Ion Detection)"]; Data [label="Data Analysis"];
```

```
Sample -> HPLC; HPLC -> ESI; ESI -> MS1; MS1 -> CID; CID -> MS2; MS2 -> Data; }
```

Caption: General workflow for LC-MS/MS analysis.

Protocol 2: GC-MS Analysis

This method is suitable for volatile and thermally stable compounds. Derivatization may be necessary for polar molecules.

1. Sample Preparation: a. Dissolve the sample in a volatile solvent such as dichloromethane or ethyl acetate.

2. Chromatographic Conditions:

- Column: A non-polar capillary column (e.g., DB-5ms, 30 m x 0.25 mm x 0.25 μ m).
- Carrier Gas: Helium at a constant flow of 1 mL/min.
- Inlet Temperature: 250 °C.
- Oven Program: Start at 100 °C, hold for 1 minute, ramp to 280 °C at 15 °C/min, and hold for 5 minutes.[3]

3. Mass Spectrometer Conditions (EI Mode):

- Ionization Energy: 70 eV.[1]
- Source Temperature: 230 °C.
- Mass Range: Scan from m/z 40-500.[1]

Summary of Predicted Fragment Ions

Ionization	Predicted m/z	Proposed Structure/Origin
ESI	351.2	[M+H] ⁺
295.1	[M+H - C ₄ H ₈] ⁺	
251.1	[M+H - C ₄ H ₈ - CO ₂] ⁺	
201.2	[1-Boc-4-aminopiperidine + H] ⁺	
152.1	[N-methyl-4-fluorobenzoyl iminium ion]	
145.1	[4-aminopiperidine + H - C ₄ H ₈] ⁺	
EI	350.2	M ^{+•}
293.2	[M - C ₄ H ₉] ⁺	
123.0	[4-fluorobenzoyl] ⁺	
57.0	[tert-butyl] ⁺	

Conclusion

The mass spectrometric fragmentation of 1-Boc-4-(4-fluoro-N-methylbenzamido)piperidine is a predictable process governed by the inherent chemical properties of its functional groups. Under ESI conditions, the most diagnostic fragmentation pathways involve the loss of the Boc protecting group and cleavage of the amide bond. Under EI, α -cleavage and the formation of stable acylium and alkyl ions are expected to dominate the spectrum. By understanding these fragmentation patterns, researchers can confidently identify this molecule, distinguish it from related impurities or analogues, and select the most appropriate analytical methodology for their research objectives. This guide provides the foundational knowledge and practical protocols to achieve these goals, ensuring data of the highest quality and integrity.

References

- Application Notes: Mass Spectrometry Fragmentation of Novel Piperidine Derivatives - Benchchem.
- Mass spectrometry for characterization of homologous piperidine alkaloids and their activity as acetylcholinesterase inhibitors - PubMed. (2018-08-15).

- Mass spectrometry for characterization of homologous piperidine alkaloids and their activity as acetylcholinesterase inhibitors | Request PDF - ResearchGate.
- A Liquid Chromatography-mass Spectrometry Method to Determine the Content of Genotoxic Impurity Piperidine in Rimonabant - Alternative Therapies In Health And Medicine.
- MASS SPECTROMETRY: FRAGMENTATION PATTERNS - eGyanKosh.
- Mass Spectrometry - Fragmentation Patterns - Chemistry LibreTexts. (2023-08-29).
- mass spectra - fragmentation patterns - Chemguide.
- Application Note: Mass Spectrometry Fragmentation Patterns of Branched Alkanes - Benchchem.

Need Custom Synthesis?

BenchChem offers custom synthesis for rare earth carbides and specific isotopic labeling.

Email: info@benchchem.com or [Request Quote Online](#).

Sources

- [1. pdf.benchchem.com](https://pdf.benchchem.com) [pdf.benchchem.com]
- [2. chemguide.co.uk](https://chemguide.co.uk) [chemguide.co.uk]
- [3. pdf.benchchem.com](https://pdf.benchchem.com) [pdf.benchchem.com]
- [4. Mass spectrometry for characterization of homologous piperidine alkaloids and their activity as acetylcholinesterase inhibitors - PubMed](#) [pubmed.ncbi.nlm.nih.gov]
- [5. researchgate.net](https://researchgate.net) [researchgate.net]
- [6. chem.libretexts.org](https://chem.libretexts.org) [chem.libretexts.org]
- [7. alternative-therapies.com](https://alternative-therapies.com) [alternative-therapies.com]
- To cite this document: BenchChem. [Introduction: The Analytical Imperative for Complex Piperidine Derivatives]. BenchChem, [2026]. [Online PDF]. Available at: [<https://www.benchchem.com/product/b2719025/docs#introduction-the-analytical-imperative-for-complex-piperidine-derivatives>]

Disclaimer & Data Validity:

The information provided in this document is for Research Use Only (RUO) and is strictly not intended for diagnostic or therapeutic procedures. While BenchChem strives to provide

accurate protocols, we make no warranties, express or implied, regarding the fitness of this product for every specific experimental setup.

Technical Support: The protocols provided are for reference purposes. Unsure if this reagent suits your experiment?

Need Industrial/Bulk Grade? [Request Custom Synthesis Quote](#)

BenchChem

Our mission is to be the trusted global source of essential and advanced chemicals, empowering scientists and researchers to drive progress in science and industry.

Contact

Address: 3281 E Guasti Rd

Ontario, CA 91761, United States

Phone: (601) 213-4426

Email: info@benchchem.com

[Contact our Ph.D. Support Team for a compatibility check](#)