

# AC 253 as a Neuroprotective Agent: A Technical Guide

**Author:** BenchChem Technical Support Team. **Date:** April 2026

## Compound of Interest

Compound Name: AC 253  
Cat. No.: B2712999

[Get Quote](#)

For Researchers, Scientists, and Drug Development Professionals

## Executive Summary

**AC 253** is a potent and selective antagonist of the amylin receptor, demonstrating significant promise as a neuroprotective agent, particularly in the context of Alzheimer's disease. Its mechanism of action is centered on the inhibition of amyloid-beta ( $A\beta$ ) oligomer-induced neurotoxicity. By blocking the AMY3 receptor subtype, **AC 253** prevents the downstream signaling cascades that lead to synaptic dysfunction, neuronal cell death, and cognitive decline. This technical guide provides a comprehensive overview of the core data, experimental protocols, and signaling pathways associated with **AC 253**'s neuroprotective effects.

## Core Mechanism of Action

**AC 253** exerts its neuroprotective effects by competitively inhibiting the binding of amylin and  $A\beta$  oligomers to the amylin receptor, a G-protein coupled receptor. The AMY3 receptor subtype, in particular, has been identified as a key mediator of  $A\beta$ 's toxic effects on neurons.<sup>[1][2]</sup> Blockade of this receptor by **AC 253** abrogates the  $A\beta$ -induced impairment of hippocampal long-term potentiation (LTP), a cellular correlate of memory, and protects against  $A\beta$ -induced apoptotic cell death.<sup>[1][3][4][5]</sup> The neuroprotective action of **AC 253** involves the prevention of

several downstream signaling events, including increases in intracellular calcium, and the activation of protein kinase A (PKA), mitogen-activated protein kinase (MAPK), and Akt.[6][7][8]

## Quantitative Data

The following tables summarize the key quantitative data for **AC 253** and its more potent, cyclized analog, cAC253.

Compound	Assay	Receptor/Target	IC50	Reference
AC 253	Inhibition of hAmylin-evoked cAMP increase	AMY3 Receptor	~0.85 $\mu$ M	[1]
cAC253	Inhibition of hAmylin-evoked cAMP increase	AMY3 Receptor	~0.3 $\mu$ M	[1][9]
AC 253	Inhibition of <sup>125</sup> I-adrenomedullin binding	Amylin Receptor	25 nM	[6]

Compound	Assay	Cell Line	Binding Affinity (Kd)	Reference
AC 253	Cell Binding Assay	AMY3-expressing HEK293	2.6 $\pm$ 1.0 $\mu$ M	[10]
cAC253	Cell Binding Assay	AMY3-expressing HEK293	1.45 $\pm$ 0.5 $\mu$ M	[10]

## Signaling Pathways and Experimental Workflows

### A $\beta$ -Induced Neurotoxicity and AC 253 Intervention

The following diagram illustrates the signaling pathway initiated by A $\beta$  oligomers through the amylin receptor and the point of intervention for **AC 253**.

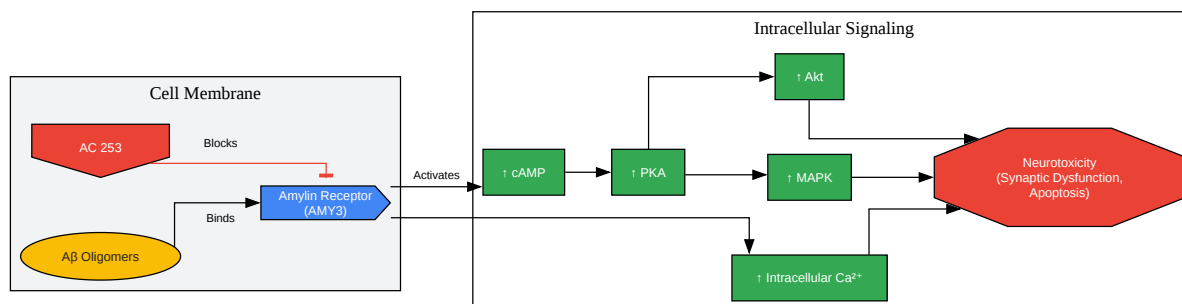

[Click to download full resolution via product page](#)

Aβ-induced neurotoxic signaling and AC 253's point of inhibition.

## Experimental Workflow: In Vitro Neuroprotection Assay

The following diagram outlines a typical workflow for assessing the neuroprotective effects of AC 253 in a cell-based assay.

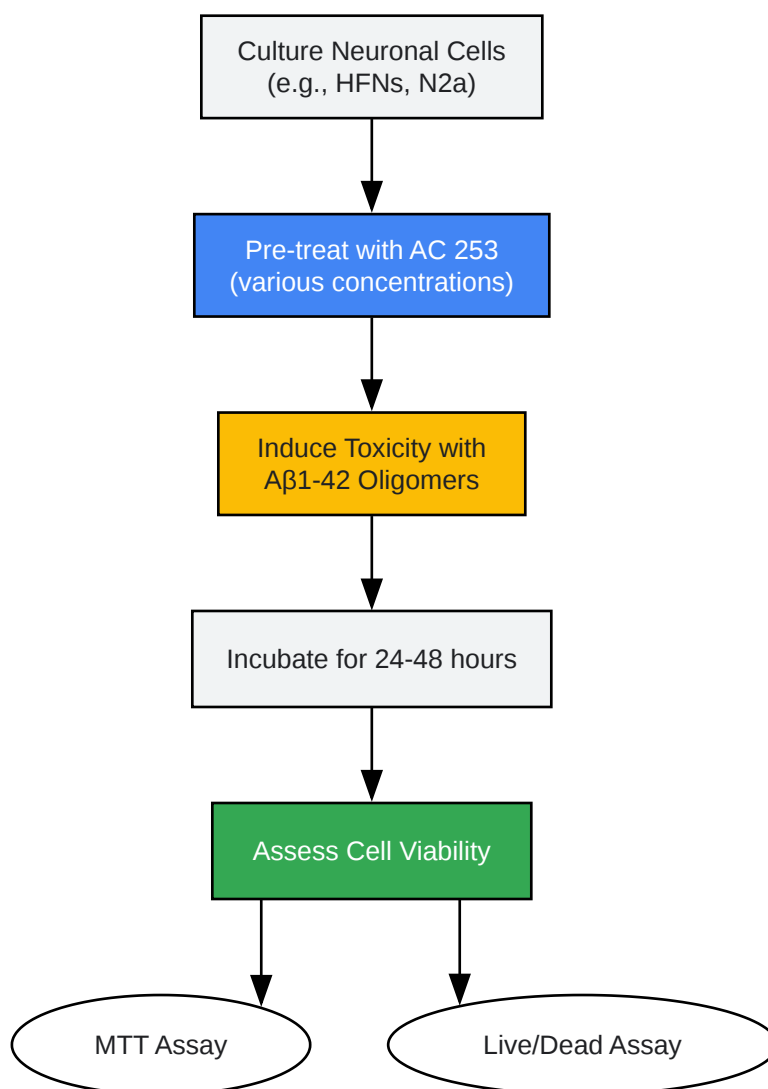

[Click to download full resolution via product page](#)

Workflow for in vitro assessment of **AC 253**'s neuroprotective efficacy.

## Experimental Protocols

### In Vitro Neuroprotection Assay Using MTT

Objective: To quantify the protective effect of **AC 253** against Aβ1-42-induced cytotoxicity in neuronal cell lines (e.g., human fetal neurons (HFNs) or N2a cells).[1][2]

Methodology:

- Cell Culture: Plate HFNs or N2a cells in 96-well plates at an appropriate density and culture under standard conditions until they reach approximately 80% confluency.

- **AC 253** Pre-treatment: Prepare serial dilutions of **AC 253** in serum-free culture medium. Remove the culture medium from the cells and add the **AC 253** solutions. Incubate for 1-2 hours.
- A $\beta$ 1-42 Oligomer Preparation: Prepare oligomeric A $\beta$ 1-42 according to established protocols.
- Toxicity Induction: Add the prepared A $\beta$ 1-42 oligomers to the wells containing the **AC 253**-treated cells to a final concentration known to induce significant cell death (e.g., 10  $\mu$ M). Include control wells with cells alone, cells with **AC 253** alone, and cells with A $\beta$ 1-42 alone.
- Incubation: Incubate the plates for 24-48 hours at 37°C in a humidified incubator with 5% CO<sub>2</sub>.
- MTT Assay:
  - Add MTT solution (3-(4,5-dimethylthiazol-2-yl)-2,5-diphenyltetrazolium bromide) to each well and incubate for 4 hours.
  - Solubilize the formazan crystals with a solubilization buffer (e.g., DMSO or a solution of SDS in HCl).
  - Measure the absorbance at 570 nm using a microplate reader.
- Data Analysis: Express cell viability as a percentage of the untreated control. Plot the percentage of viability against the concentration of **AC 253** to determine the dose-dependent neuroprotective effect.

## Measurement of cAMP Levels via In-Cell Western Assay

Objective: To determine the inhibitory effect of **AC 253** on amylin-induced cAMP production in cells expressing the AMY3 receptor.[\[1\]](#)[\[2\]](#)[\[4\]](#)

Methodology:

- Cell Culture: Seed HEK293 cells stably expressing the AMY3 receptor in 96-well plates and grow to confluency.
- Treatment:

- Starve the cells in serum-free medium for a designated period.
- Pre-treat the cells with various concentrations of **AC 253** for 30 minutes.
- Stimulate the cells with a fixed concentration of human amylin (e.g., 1  $\mu$ M) for 15 minutes to induce cAMP production.
- Fixation and Permeabilization:
  - Fix the cells with 4% paraformaldehyde in PBS.
  - Permeabilize the cells with a solution of 0.1% Triton X-100 in PBS.
- Immunostaining:
  - Block non-specific binding with a blocking buffer (e.g., Odyssey Blocking Buffer).
  - Incubate the cells with a primary antibody against cAMP.
  - Wash the cells and incubate with an appropriate IRDye-conjugated secondary antibody.
- Detection: Scan the plate using an infrared imaging system (e.g., Odyssey scanner) to quantify the fluorescence intensity, which is proportional to the cAMP level.
- Data Analysis: Normalize the cAMP signal to cell number (e.g., by co-staining with a nuclear stain). Plot the normalized cAMP levels against the concentration of **AC 253** to determine the IC50 value for the inhibition of amylin-induced cAMP production.

## Assessment of Hippocampal Long-Term Potentiation (LTP)

Objective: To evaluate the ability of **AC 253** to reverse A $\beta$ -induced deficits in synaptic plasticity in hippocampal slices.

Methodology:

- Hippocampal Slice Preparation: Prepare transverse hippocampal slices (300-400  $\mu$ m thick) from adult rodents using a vibratome in ice-cold artificial cerebrospinal fluid (aCSF).

- Slice Recovery: Allow the slices to recover in an interface chamber with oxygenated aCSF at room temperature for at least 1 hour.
- Electrophysiological Recording:
  - Transfer a slice to a recording chamber continuously perfused with oxygenated aCSF.
  - Place a stimulating electrode in the Schaffer collateral pathway and a recording electrode in the stratum radiatum of the CA1 region to record field excitatory postsynaptic potentials (fEPSPs).
- Baseline Recording: Establish a stable baseline of fEPSPs for at least 20 minutes by delivering single pulses at a low frequency (e.g., 0.033 Hz).
- A $\beta$  Application: Perfuse the slice with aCSF containing A $\beta$  oligomers to induce a depression of the fEPSP slope.
- **AC 253** Application: After the A $\beta$ -induced depression has stabilized, co-perfuse the slice with A $\beta$  and **AC 253**.
- LTP Induction: Induce LTP using a high-frequency stimulation protocol, such as theta-burst stimulation (TBS), which typically consists of multiple trains of high-frequency bursts (e.g., 10 bursts of 4 pulses at 100 Hz, repeated at 5 Hz).[\[11\]](#)
- Post-Induction Recording: Continue to record fEPSPs for at least 60 minutes after TBS to assess the magnitude and stability of LTP.
- Data Analysis: Normalize the fEPSP slope to the pre-LTP baseline. Compare the degree of potentiation in slices treated with A $\beta$  alone versus those treated with A $\beta$  and **AC 253**.

## Conclusion and Future Directions

**AC 253** has demonstrated a clear neuroprotective profile in preclinical models of Alzheimer's disease. Its well-defined mechanism of action, centered on the antagonism of the amylin receptor, provides a strong rationale for its further development. The development of more stable and brain-penetrant analogs, such as cAC253, addresses some of the limitations of peptide-based therapeutics.[\[1\]\[3\]](#) Future research should focus on comprehensive in vivo

efficacy and safety studies in higher animal models to pave the way for potential clinical investigation. The amylin receptor remains a promising therapeutic target for disease-modifying therapies for Alzheimer's disease and related neurodegenerative conditions.[1][5]

### Need Custom Synthesis?

BenchChem offers custom synthesis for rare earth carbides and specific isotopic labeling.

Email: [info@benchchem.com](mailto:info@benchchem.com) or [Request Quote Online](#).

## References

- 1. Cyclic AC253, a novel amylin receptor antagonist, improves cognitive deficits in a mouse model of Alzheimer's disease - PMC [[pmc.ncbi.nlm.nih.gov](https://pubmed.ncbi.nlm.nih.gov)]
- 2. [researchgate.net](https://www.researchgate.net) [[researchgate.net](https://www.researchgate.net)]
- 3. "Cyclic AC253, A Novel Amylin Receptor Antagonist, Improves Cognitive D" by Rania Soudy, Aarti Patel et al. [[digitalcommons.chapman.edu](https://digitalcommons.chapman.edu)]
- 4. [ovid.com](https://www.ovid.com) [[ovid.com](https://www.ovid.com)]
- 5. Cyclic AC253, a novel amylin receptor antagonist, improves cognitive deficits in a mouse model of Alzheimer's disease - PubMed [[pubmed.ncbi.nlm.nih.gov](https://pubmed.ncbi.nlm.nih.gov)]
- 6. [medchemexpress.com](https://www.medchemexpress.com) [[medchemexpress.com](https://www.medchemexpress.com)]
- 7. [glpbio.com](https://www.glpbio.com) [[glpbio.com](https://www.glpbio.com)]
- 8. Amyloid  $\beta$  (A $\beta$ ) Peptide Directly Activates Amylin-3 Receptor Subtype by Triggering Multiple Intracellular Signaling Pathways - PMC [[pmc.ncbi.nlm.nih.gov](https://pubmed.ncbi.nlm.nih.gov)]
- 9. [medchemexpress.com](https://www.medchemexpress.com) [[medchemexpress.com](https://www.medchemexpress.com)]
- 10. [researchgate.net](https://www.researchgate.net) [[researchgate.net](https://www.researchgate.net)]
- 11. Time-Dependent Reversal of Long-Term Potentiation by an Integrin Antagonist - PMC [[pmc.ncbi.nlm.nih.gov](https://pubmed.ncbi.nlm.nih.gov)]
- To cite this document: BenchChem. [AC 253 as a Neuroprotective Agent: A Technical Guide]. BenchChem, [2026]. [Online PDF]. Available at: [<https://www.benchchem.com/product/b2712999/docs#ac-253-as-a-neuroprotective-agent-a-technical-guide>]

---

### Disclaimer & Data Validity:

The information provided in this document is for Research Use Only (RUO) and is strictly not intended for diagnostic or therapeutic procedures. While BenchChem strives to provide accurate protocols, we make no warranties, express or implied, regarding the fitness of this product for every specific experimental setup.

**Technical Support:** The protocols provided are for reference purposes. Unsure if this reagent suits your experiment?

**Need Industrial/Bulk Grade?** [Request Custom Synthesis Quote](#)

## BenchChem

Our mission is to be the trusted global source of essential and advanced chemicals, empowering scientists and researchers to drive progress in science and industry.

### Contact

Address: 3281 E Guasti Rd  
Ontario, CA 91761, United States  
Phone: (601) 213-4426  
Email: [info@benchchem.com](mailto:info@benchchem.com)

[Contact our Ph.D. Support Team for a compatibility check](#)