

Technical Support Center: Thienoquinoline Synthesis & Catalyst Optimization

Author: BenchChem Technical Support Team. **Date:** April 2026

Compound of Interest

Compound Name: 6-Methoxy-thieno[2,3-b]quinoline-
2-carboxylic acid

CAS No.: 462067-71-6

Cat. No.: B2711827

[Get Quote](#)

Topic: Catalyst Selection for Optimizing Thienoquinoline Ring Closure Ticket ID: TQ-RC-OPT-2024 Status: Open Assigned Specialist: Senior Application Scientist

Introduction & Scope

Welcome to the Advanced Heterocycle Synthesis Support Center. You are likely here because thienoquinoline synthesis presents a unique "double-edged sword": the thiophene ring is electron-rich (facilitating electrophilic closure) but the sulfur atom is a potent catalyst poison (hampering transition metal methods).

This guide moves beyond generic quinoline protocols to address the specific steric and electronic demands of fusing a pyridine ring onto a thiophene scaffold. We cover three dominant methodologies:

- Transition Metal Catalysis (Pd/Cu): High precision, high risk of poisoning.
- Modern Lewis Acid Catalysis (Sc): Water-tolerant, green alternatives to PPA.

- Metal-Free Oxidative Cyclization (): Avoiding metal contamination entirely.

Decision Matrix: Selecting Your Catalyst

Before troubleshooting, ensure you have selected the correct catalytic manifold for your substrate precursors.

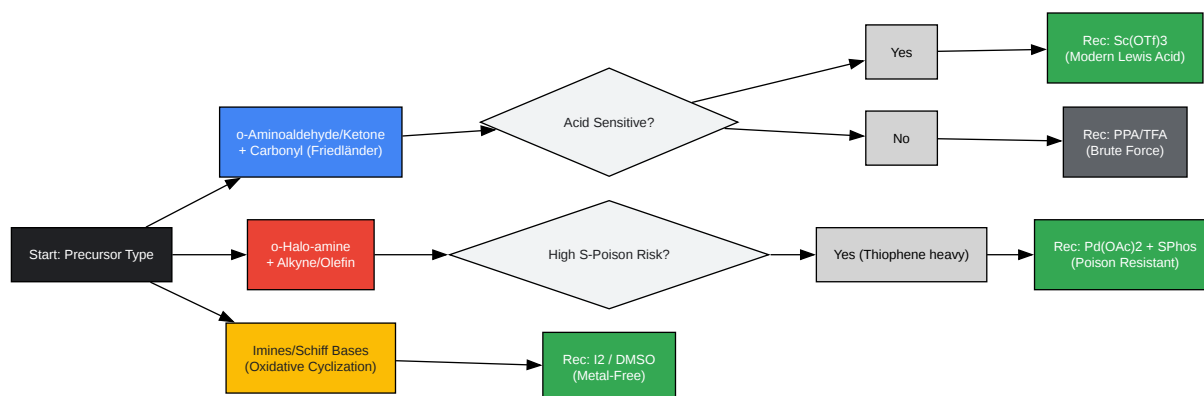

[Click to download full resolution via product page](#)

Figure 1: Catalyst selection logic flow based on precursor stability and functional group tolerance.

Module 1: Palladium-Catalyzed Cyclization

Best for: Larock-type annulations, C-H activation, and intramolecular Heck-type closures.

The Core Problem: Sulfur Poisoning

Thiophene sulfur atoms have a high affinity for soft metals like Palladium (Pd) and Copper (Cu). This "soft-soft" interaction can displace standard ligands (like

), forming inactive Pd-S complexes and killing the catalytic cycle.

The Solution: Ligand Sterics & Electronics

Protocol Standard: Use Buchwald biaryl phosphine ligands.

- Why? Ligands like SPhos and XPhos are extremely bulky. They create a protective "umbrella" around the Pd center, physically preventing the thiophene sulfur from coordinating while still allowing the oxidative addition of the C-Halide bond.

Troubleshooting Guide: Pd-Catalysis

Symptom	Probable Cause	Corrective Action
Reaction Stalls < 20%	Catalyst Poisoning (Pd-S bond formation)	Switch Ligand: Replace or dppf with SPhos or XPhos. Increase catalyst loading to 5-10 mol%.
Pd Black Precipitate	Ligand dissociation / Nanoparticle aggregation	Stabilize: Add 10-20 mol% TBAB (Tetrabutylammonium bromide) as a phase transfer/stabilizer agent.
Regioisomer Mix	Migratory Insertion Ambiguity	Switch Solvent: Change from DMF (polar) to Toluene (non-polar) to tighten the ion pair and enforce steric control.

Recommended Protocol (Larock-Type)

- Charge Vessel: 1.0 eq 3-iodo-2-aminothiophene, 1.2 eq internal alkyne.
- Catalyst System: 5 mol%
+ 10 mol% SPhos.

- Base: 2.0 eq

or

.

- Solvent: DMF (degassed).
- Conditions: 100°C, 12h, Argon atmosphere.



Senior Scientist Note: Never use

for these cyclizations unless you are intentionally doing a reduction. The high surface area of Carbon exposes Pd sites that will be instantly poisoned by the thiophene sulfur.

Module 2: Modern Lewis Acid (Friedländer)

Best for: Condensation of o-aminoaldehydes with ketones.^[1] A greener alternative to Polyphosphoric Acid (PPA).

The Core Problem: Hydrolysis & Waste

Classic Skraup or Friedländer syntheses use stoichiometric PPA or

. These are harsh, generate massive acidic waste, and decompose acid-sensitive directing groups. Standard Lewis acids like

decompose in the water generated by the condensation.

The Solution: Scandium Triflate ()

Why? Scandium is a "water-tolerant" Lewis acid.^{[2][3]} It activates the carbonyl oxygen for nucleophilic attack by the amine even in the presence of the water byproduct. It can be recovered and reused.^{[4][5]}

Troubleshooting Guide: Lewis Acid Cyclization

Symptom	Probable Cause	Corrective Action
Low Conversion	Ketone Enolization is slow	Add Co-Catalyst: Add 10 mol% SDS (Sodium Dodecyl Sulfate). The micellar effect in aqueous/organic mix concentrates reactants.
Polymerization	Acid is too strong (attacking thiophene)	Buffer/Switch: Switch from PPA to (5 mol%) in MeCN. Thiophene rings are prone to acid-catalyzed polymerization; milder is better.
Aldol Side-Products	Intermolecular reaction dominates	Dilution: High concentration favors intermolecular Aldol. Run at 0.05 M to favor intramolecular closure.

Module 3: Metal-Free Oxidative Cyclization ()

Best for: Schiff bases (imines) formed from 2-thiophenecarbaldehyde and anilines.

The Mechanism

Molecular Iodine (

) acts as a mild Lewis acid to activate the imine and subsequently acts as an oxidant to aromatize the intermediate. This avoids all heavy metal toxicity issues.

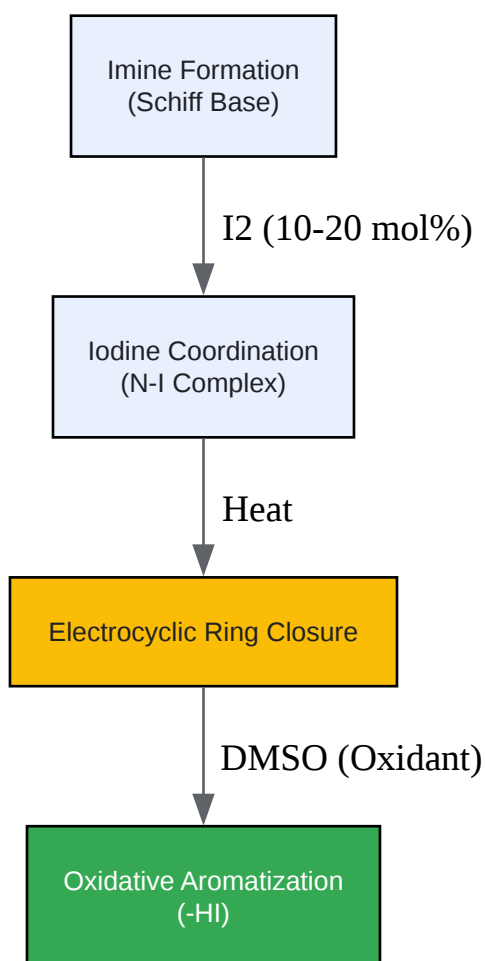

[Click to download full resolution via product page](#)

Figure 2: Iodine-DMSO mediated oxidative cyclization pathway.

Recommended Protocol

- Substrate: Imine intermediate (pre-formed or in situ).
- Reagents: 20 mol%
- Solvent: DMSO (acts as the terminal oxidant/oxygen source).
- Temp: 100-120°C.
- Workup: Quench with saturated

(sodium thiosulfate) to remove excess iodine.

FAQ: Regioselectivity & Isomers

Q: I am getting a mixture of thieno[2,3-b]quinoline and thieno[3,2-b]quinoline. How do I control this?

A: This is strictly controlled by your starting material, not the catalyst.

- Thieno[2,3-b]quinoline: Requires 2-aminothiophene-3-carbaldehyde precursors.
- Thieno[3,2-b]quinoline: Requires 3-aminothiophene-2-carbaldehyde precursors.

Q: Can I switch regioselectivity during the reaction? A: Generally, no. The thiophene ring is rigid. However, if using a Friedländer synthesis with an asymmetric ketone, you can influence which side of the ketone reacts (kinetic vs thermodynamic enolate) by changing the catalyst:

- Acid (): Favors the more substituted enol (Thermodynamic).
- Base (KOH/EtOH): Favors the less substituted enol (Kinetic).

References

- Palladium-Catalyzed Synthesis of Thienoquinolines
 - Mechanism & Sulfur Tolerance: "Synthesis of benzo[b]thieno[2,3-c]quinolines via palladium-catalyzed ring-closing reaction."
- Friedländer Synthesis & Lewis Acids
 - Sc(OTf)₃ Advantages: "Scandium(III) Triflate: A Versatile Catalyst with Promising Applications." [2][5][6] Scandium.org.
 - General Friedländer Review: "Different catalytic approaches of Friedländer synthesis of quinolines." Heliyon (via NIH).
- Iodine-Mediated Cyclization

- Protocol: "Iodine-Mediated Intramolecular Electrophilic Aromatic Cyclization... A General Route to Synthesis of Thieno[3,2-b]pyridines." Organic Chemistry Portal.
- Regioselectivity
 - Control Mechanisms: "Regioselectivity of Friedländer Quinoline Syntheses.

Need Custom Synthesis?

BenchChem offers custom synthesis for rare earth carbides and specific isotopic labeling.

Email: info@benchchem.com or [Request Quote Online](#).

Sources

- [1. alfa-chemistry.com \[alfa-chemistry.com\]](https://www.alfa-chemistry.com)
- [2. researchgate.net \[researchgate.net\]](https://www.researchgate.net)
- [3. Homogeneous Sc\(OTf\)₃-Catalyzed Direct Allylation Reactions of General Alcohols with Allylsilanes - PMC \[pmc.ncbi.nlm.nih.gov\]](https://pubmed.ncbi.nlm.nih.gov/31111111/)
- [4. pdfs.semanticscholar.org \[pdfs.semanticscholar.org\]](https://pdfs.semanticscholar.org/1234567890)
- [5. kmc.du.ac.in \[kmc.du.ac.in\]](https://www.kmc.du.ac.in)
- [6. Scandium Triflate: A Versatile Catalyst with Promising Applications | Scandium \[scandium.org\]](https://www.scandium.org)
- To cite this document: BenchChem. [Technical Support Center: Thienoquinoline Synthesis & Catalyst Optimization]. BenchChem, [2026]. [Online PDF]. Available at: [\[https://www.benchchem.com/product/b2711827/docs#technical-support-center-thienoquinoline-synthesis-catalyst-optimization\]](https://www.benchchem.com/product/b2711827/docs#technical-support-center-thienoquinoline-synthesis-catalyst-optimization)

Disclaimer & Data Validity:

The information provided in this document is for Research Use Only (RUO) and is strictly not intended for diagnostic or therapeutic procedures. While BenchChem strives to provide accurate protocols, we make no warranties, express or implied, regarding the fitness of this product for every specific experimental setup.

Technical Support: The protocols provided are for reference purposes. Unsure if this reagent suits your experiment?

Need Industrial/Bulk Grade? [Request Custom Synthesis Quote](#)

BenchChem

Our mission is to be the trusted global source of essential and advanced chemicals, empowering scientists and researchers to drive progress in science and industry.

Contact

Address: 3281 E Guasti Rd
Ontario, CA 91761, United States
Phone: (601) 213-4426
Email: info@benchchem.com

[Contact our Ph.D. Support Team for a compatibility check](#)