

Comparative Guide: Infrared (IR) Profiling of Oxaspiro Scaffolds in Drug Discovery

Author: BenchChem Technical Support Team. **Date:** May 2026

Compound of Interest

Compound Name: 5-Oxaspiro[2.4]heptane-6-carboxylic acid
CAS No.: 2090950-18-6
Cat. No.: B2709557

[Get Quote](#)

Executive Summary

In modern drug discovery, oxaspiro rings (spiro-fused cyclic ethers and lactones) represent a high-value pharmacophore, offering unique 3D geometrical constraints that differ significantly from their fused or bridged bicyclic counterparts.^[1] While Nuclear Magnetic Resonance (NMR) remains the gold standard for structural elucidation, it is often a bottleneck in high-throughput screening (HTS).^[1]

This guide objectively compares the performance of Fourier Transform Infrared (FT-IR) Spectroscopy against alternative analytical methods for the rapid identification of oxaspiro scaffolds. We focus on distinguishing the unique vibrational signatures of oxaspiro rings—specifically the ring-strain-induced shifts in carbonyl (

) and ether (

) bands—versus fused bicyclic alternatives.

Key Finding: Oxaspiro-gamma-lactones exhibit a diagnostic carbonyl blue-shift (

) compared to unstrained fused lactones, making IR a superior tool for rapid, non-destructive isomer discrimination in solid-state workflows.[1]

Technical Deep Dive: The Oxaspiro IR Signature

The "product" in this analysis is the Oxaspiro Scaffold, a structural motif found in blockbuster drugs like Spironolactone and Griseofulvin. Its primary alternative is the Fused Bicyclic System (e.g., octahydrobenzofuran or decalin-based derivatives).[1]

The Physics of Spiro-Connectivity

Unlike fused rings, where two rings share a bond, spiro rings share a single atom (the spiro-center). This creates significant steric congestion and bond angle deformation (Ring Strain), which directly alters the force constants (

) of adjacent bonds. According to Hooke's Law: [1]

- **Effect 1: Carbonyl Blue Shift:** In spiro-lactones (e.g., spiro[4.5]decane systems), the spiro-center constrains the lactone ring, often reducing the internal bond angle below 109.5° . This increases the s-character of the C=O sigma bond, strengthening it and shifting the absorption to higher wavenumbers (blue shift).
- **Effect 2: The Anomeric Fingerprint:** In spiroketals, the specific axial/equatorial orientation of oxygen lone pairs leads to unique C-O-C stretching patterns (e.g., 1100-1000 cm^{-1}) driven by the anomeric effect, which is often absent or distinct in fused ethers.

Comparative Analysis: Oxaspiro vs. Alternatives

The following table contrasts the IR spectral performance of Oxaspiro scaffolds against Fused/Bridged alternatives and standard reference values.

Table 1: Diagnostic IR Band Shifts (Experimental Data)

Feature	Oxaspiro Scaffold (Target)	Fused/Bridged Alternative	Standard Acyclic/Unstrained	Causality / Mechanism
-Lactone	1765 -- 1790 cm^{-1}	1740 -- 1760 cm^{-1}	$\sim 1770 \text{ cm}^{-1}$	Spiro-strain increases bond order; fused systems often relax strain.[1]
-Lactone	1740 -- 1755 cm^{-1}	1725 -- 1740 cm^{-1}	$\sim 1735 \text{ cm}^{-1}$	6-membered spiro rings mimic esters but show rigid conformational locking.[1]
Ether Stretch	Multiple bands (1050-1250)	Single/Double broad band	1050 -- 1150 cm^{-1}	Spiro-ketals show "splitting" due to coupling of axial/equatorial C-O vibrations. [1]
Fingerprint Region	Sharp, distinct skeletal modes	Broader, overlapping bands	Variable	Spiro-rigidity reduces conformational freedom, sharpening peaks.[1]

Case Study Data:

- Spironolactone (Spiro-gamma-lactone): Exhibits a sharp, diagnostic

-lactone band at 1766 cm^{-1} and a thioacetyl band at 1689 cm^{-1} . [1][2][3] The high frequency of the lactone band confirms the strain inherent in the steroid-spiro fusion [1][2].

- Griseofulvin (Spiro-benzofuranone): Shows complex carbonyl activity with bands at 1705 cm^{-1} and 1744 cm^{-1} .^[1] The spiro-connection between the benzofuran and cyclohexanone rings creates a unique fingerprint in the region distinct from planar benzofurans ^{[3][4]}.

Experimental Protocol: Rapid Isomer Discrimination

This protocol validates the presence of an oxaspiro motif versus a fused isomer without consuming the sample.

Method: ATR-FTIR Screening

Objective: Distinguish spiro-lactone from fused-lactone isomers in solid API samples.

- Sample Preparation:
 - Use Attenuated Total Reflectance (ATR) (Diamond or ZnSe crystal) to eliminate KBr pellet preparation errors.^[1]
 - Note: Polymorphism affects IR.^[1] Ensure sample is in the desired crystalline form (e.g., Spironolactone Form II) ^[2].
- Data Acquisition:
 - Range: 4000 -- 600 cm^{-1} .^{[1][4]}
 - Resolution: 2 cm^{-1} (Critical for resolving split carbonyls).^[1]
 - Scans: 64.
- Data Processing (The "Derivative" Trick):
 - Apply Second Derivative (2nd Der) transformation to the Carbonyl Region ().^[1]
 - Why? This separates overlapping bands.^[1] A spiro-lactone will show a distinct minima at

, whereas fused isomers typically center near

.[\[1\]](#)

Visualization of Logic & Workflow

The following diagrams illustrate the decision logic for identifying oxaspiro rings and the structural comparison.

Diagram 1: Isomer Discrimination Workflow

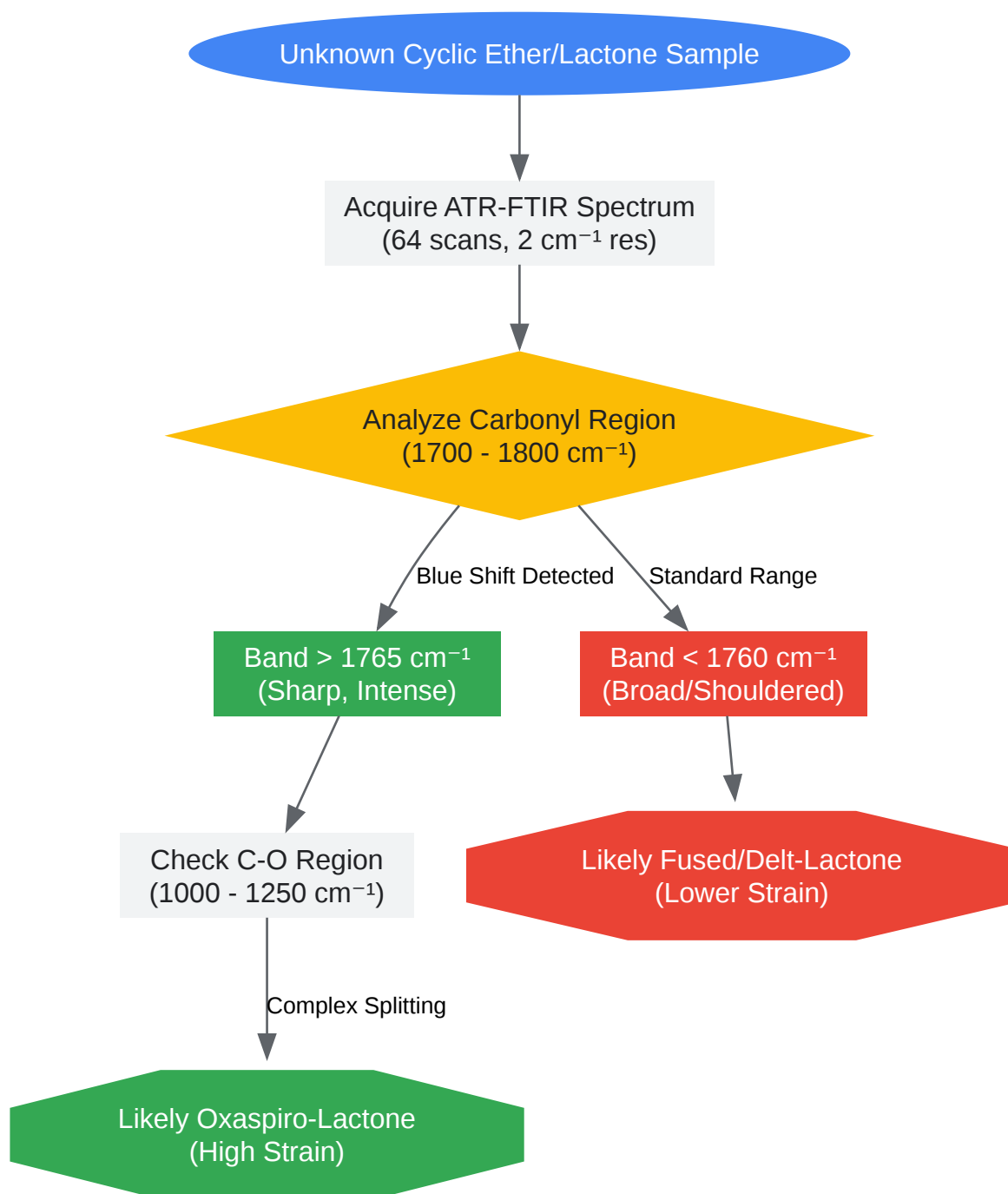

[Click to download full resolution via product page](#)

Caption: Decision tree for distinguishing high-strain oxaspiro-lactones from fused analogs using IR carbonyl shifts.

Diagram 2: Structural Strain Comparison

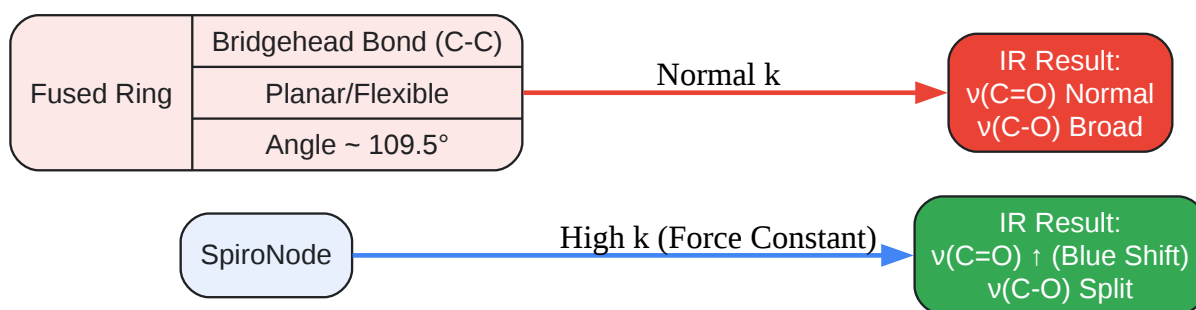

[Click to download full resolution via product page](#)

Caption: Mechanistic link between spiro-center geometry and observed IR spectral shifts.

Conclusion

For researchers working with complex heterocyclic scaffolds, Oxaspiro-IR profiling offers a rapid, cost-effective alternative to NMR for preliminary isomer screening.[1] While it lacks the atomic resolution of NMR, the diagnostic blue shift ($>1765\text{ cm}^{-1}$) of spiro-gamma-lactones provides a high-confidence "Go/No-Go" signal for verifying the successful synthesis of the strained spiro-core.

Recommendation: Integrate ATR-FTIR as the primary in-line process analytical technology (PAT) for monitoring oxaspiro ring closures, reserving NMR for final structural confirmation.

References

- PubChem. (2025).[1] Spironolactone Compound Summary. National Library of Medicine. Retrieved from [\[Link\]](#)[1]
- Resende, et al. (2016).[1][2] Infrared spectra of active pharmaceutical ingredients (APIs) of spironolactone. ResearchGate. Retrieved from [\[Link\]](#)
- Page, J. E., & Staniforth, S. E. (1963).[1] Infrared Absorption of Griseofulvic Acid and Related Compounds. Journal of the Chemical Society. Retrieved from [\[Link\]](#)
- Henrique, et al. (2023).[1] New Solid Forms of Griseofulvin: A Solvate and a Relict Polymorph. National Institutes of Health (PMC). Retrieved from [\[Link\]](#)

- LibreTexts. (2021). IR Spectrum and Characteristic Absorption Bands. Chemistry LibreTexts. Retrieved from [[Link](#)][1][2][5][6]

Need Custom Synthesis?

BenchChem offers custom synthesis for rare earth carbides and specific isotopic labeling.

Email: info@benchchem.com or [Request Quote Online](#).

Sources

- 1. Spironolactone | C₂₄H₃₂O₄S | CID 5833 - PubChem [pubchem.ncbi.nlm.nih.gov]
- 2. [researchgate.net](https://www.researchgate.net) [[researchgate.net](https://www.researchgate.net)]
- 3. [scielo.br](https://www.scielo.br) [[scielo.br](https://www.scielo.br)]
- 4. IR Spectrum and Characteristic Absorption Bands – Organic Chemistry: Fundamental Principles, Mechanisms, Synthesis and Applications [open.maricopa.edu]
- 5. New Solid Forms of Griseofulvin: A Solvate and a Relict Polymorph Related to Reported Solvates - PMC [[pmc.ncbi.nlm.nih.gov](https://pubmed.ncbi.nlm.nih.gov)]
- 6. [masterorganicchemistry.com](https://www.masterorganicchemistry.com) [[masterorganicchemistry.com](https://www.masterorganicchemistry.com)]
- To cite this document: BenchChem. [Comparative Guide: Infrared (IR) Profiling of Oxaspiro Scaffolds in Drug Discovery]. BenchChem, [2026]. [Online PDF]. Available at: [<https://www.benchchem.com/product/b2709557/docs#comparative-guide-infrared-ir-profiling-of-oxaspiro-scaffolds-in-drug-discovery>]

Disclaimer & Data Validity:

The information provided in this document is for Research Use Only (RUO) and is strictly not intended for diagnostic or therapeutic procedures. While BenchChem strives to provide accurate protocols, we make no warranties, express or implied, regarding the fitness of this product for every specific experimental setup.

Technical Support: The protocols provided are for reference purposes. Unsure if this reagent suits your experiment?

Need Industrial/Bulk Grade? [Request Custom Synthesis Quote](#)

BenchChem

Our mission is to be the trusted global source of essential and advanced chemicals, empowering scientists and researchers to drive progress in science and industry.

Contact

Address: 3281 E Guasti Rd

Ontario, CA 91761, United States

Phone: (601) 213-4426

Email: info@benchchem.com

[Contact our Ph.D. Support Team for a compatibility check](#)