

# Technical Comparison Guide: GC-MS Fragmentation Patterns of Benzyl Cycloheptanecarboxylate

**Author:** BenchChem Technical Support Team. **Date:** May 2026

## Compound of Interest

Compound Name:	<i>Benzyl cycloheptanecarboxylate</i>
CAS No.:	1260882-66-3
Cat. No.:	B2706540

[Get Quote](#)

## Executive Summary: The Structural Isomer Challenge

In pharmaceutical intermediate analysis and forensic chemistry, the precise identification of ester functionalities is critical. **Benzyl cycloheptanecarboxylate** (MW 232.32 Da) presents a specific analytical challenge: it is a structural isomer of phenethyl cyclohexanecarboxylate.

Both compounds share the formula

and possess similar non-polar retention characteristics on standard 5%-phenyl-methylpolysiloxane GC columns.

This guide provides an objective technical comparison of the GC-MS fragmentation performance of **benzyl cycloheptanecarboxylate** against its isomers and homologs. By analyzing the mechanistic causality of ionization, we establish a self-validating protocol to distinguish the benzyl ester (Target) from the phenethyl ester (Alternative 1) and the benzyl cyclohexyl homolog (Alternative 2).

## Theoretical Framework: Fragmentation Mechanics

To interpret the mass spectrum accurately, one must understand the driving forces behind the fragmentation. The two dominant mechanisms for these esters under Electron Ionization (EI, 70 eV) are

-Cleavage and Rearrangements.

### The Benzyl Ester Signature (The Target)

Benzyl esters are characterized by the stability of the benzyl cation. Upon ionization, the bond between the carbonyl carbon and the benzyloxy oxygen is susceptible to cleavage, but the most distinct pathway involves the cleavage of the benzyl-oxygen bond.

- Mechanism: The molecular ion (  $m/z$  232) undergoes fragmentation to yield the benzyl cation (  $m/z$  91), which rapidly rearranges to the highly stable tropylium ion ( $m/z$  91).
- Secondary Fragment: The remaining acylium ion (  $m/z$  125) appears at  $m/z$  125.

### The Phenethyl Ester Signature (The Alternative)

Phenethyl esters (  $m/z$  104)

) possess a hydrogen atom on the

$\alpha$ -carbon of the alcohol chain (relative to the oxygen). This enables a McLafferty-like rearrangement (specifically, a hydrogen transfer followed by elimination).

- Mechanism: The ester eliminates the carboxylic acid, generating a radical cation of styrene (  $m/z$  104).
- Diagnostic Result: A dominant base peak at  $m/z$  104 is the hallmark of phenethyl esters, distinguishing them from benzyl esters.

## Comparative Analysis: Target vs. Alternatives

The following table summarizes the quantitative mass spectral differences required for positive identification.

### Table 1: Diagnostic Ion Comparison

Feature	Benzyl Cycloheptanecarboxy- late ( <b>Target</b> )	Phenethyl Cyclohexanecarboxy- late ( <b>Isomer</b> )	Benzyl Cyclohexanecarboxy- late ( <b>Homolog</b> )
Molecular Weight	232 Da	232 Da	218 Da
Base Peak (100%)	m/z 91 (Tropylium)	m/z 104 (Styrene radical)	m/z 91 (Tropylium)
Molecular Ion ( )	m/z 232 (Trace/Weak)	m/z 232 (Trace/Weak)	m/z 218 (Trace/Weak)
Acylium Ion ( )	m/z 125 (Cycloheptyl- CO)	m/z 111 (Cyclohexyl- CO)	m/z 111 (Cyclohexyl- CO)
Secondary Ions	m/z 65, 55 (Ring fragments)	m/z 105 (Phenethyl cation)	m/z 65, 55
Key Distinction	High 91 / Low 104	High 104 / Moderate 91	Shift in Acylium (+14 Da diff)

“

*Analyst Note: If your spectrum shows m/z 104 as the base peak, you have likely misidentified the phenethyl isomer as the benzyl target.*

## Visualizing the Fragmentation Pathways[3][4][5]

The following diagram illustrates the divergent fragmentation pathways that allow for structural differentiation.

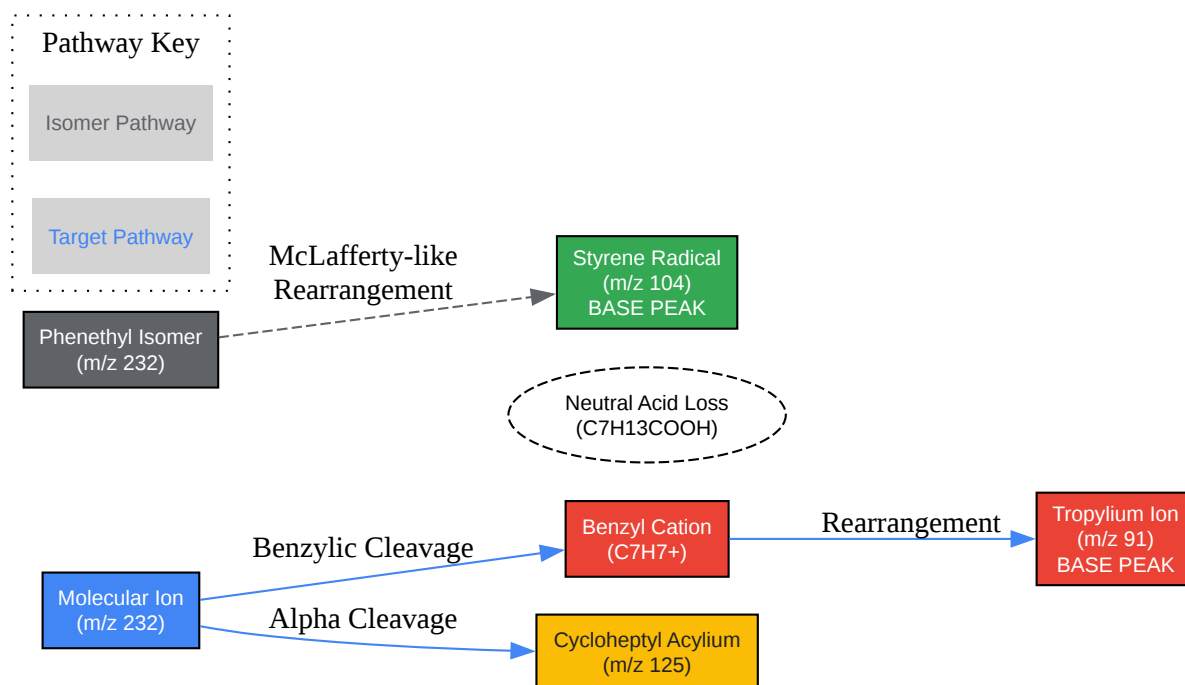

[Click to download full resolution via product page](#)

Figure 1: Mechanistic divergence between Benzyl and Phenethyl ester fragmentation.[1] The formation of m/z 91 vs. m/z 104 is the primary discriminator.

## Experimental Protocol: Self-Validating Identification

To ensure reproducibility and data integrity, follow this standardized GC-MS workflow. This protocol includes a "Decision Tree" logic step to validate the identity of the peak.

### Method Parameters[6]

- Instrument: GC-MS (Single Quadrupole or Q-TOF).

- Column: 30m x 0.25mm ID, 0.25µm film thickness (5%-phenyl-methylpolysiloxane, e.g., DB-5MS or equivalent).
- Carrier Gas: Helium at 1.0 mL/min (Constant Flow).
- Inlet: Splitless (250°C).
- Oven Program: 60°C (1 min hold)  
20°C/min to 280°C  
Hold 5 min.
- Ion Source: EI (70 eV), 230°C.
- Scan Range: m/z 40–350.

## Identification Workflow

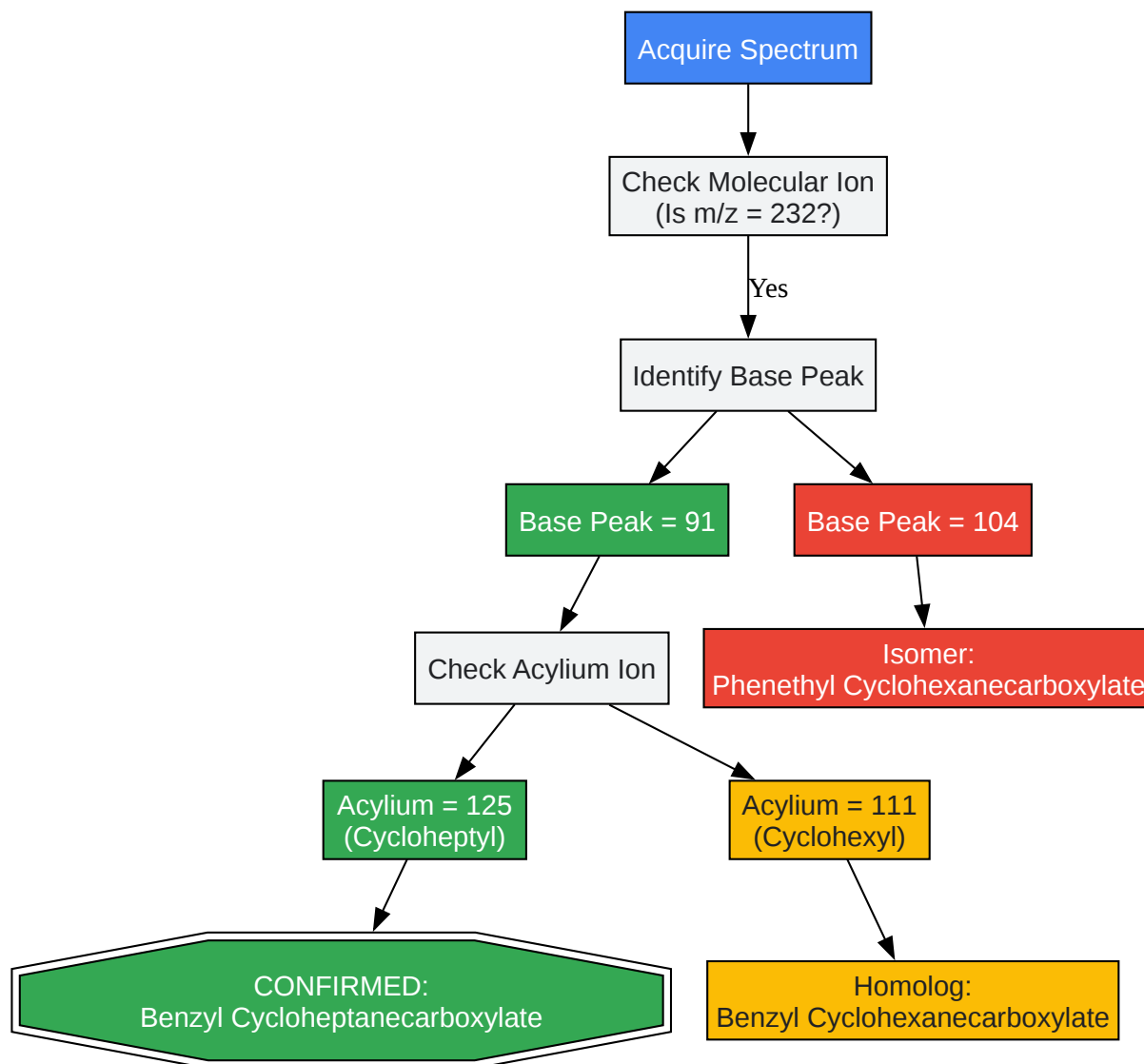

[Click to download full resolution via product page](#)

Figure 2: Decision tree for the identification of **Benzyl Cycloheptanecarboxylate**, filtering out common homologs and isomers.

## References

- NIST Mass Spectrometry Data Center. Benzyl cyclohexanecarboxylate (Homolog Data).<sup>[2]</sup> National Institute of Standards and Technology. Available at: [\[Link\]](#)
- PubChem. 2-Phenylethyl cyclohexanecarboxylate (Isomer Data).<sup>[3][4]</sup> National Library of Medicine. Available at: [\[Link\]](#)
- eGyanKosh. Mass Spectrometry: Fragmentation Patterns (Aromatic Esters). Available at: [\[Link\]](#)
- Chemistry LibreTexts. Fragmentation Patterns: Esters and Aromatics. Available at: [\[Link\]](#)<sup>[5][6]</sup>  
<sup>[1][7][8][9][10][11]</sup>

### Need Custom Synthesis?

BenchChem offers custom synthesis for rare earth carbides and specific isotopic labeling.

Email: [info@benchchem.com](mailto:info@benchchem.com) or [Request Quote Online](#).

## Sources

- 1. Mass Spectral Fragmentation Pathways of Phthalate Esters by Gas C...: Ingenta Connect [\[ingentaconnect.com\]](http://ingentaconnect.com)
- 2. Phenethyl phenylacetate | C<sub>16</sub>H<sub>16</sub>O<sub>2</sub> | CID 7601 - PubChem [\[pubchem.ncbi.nlm.nih.gov\]](http://pubchem.ncbi.nlm.nih.gov)
- 3. 2-Phenylethyl cyclohexanecarboxylate | C<sub>15</sub>H<sub>20</sub>O<sub>2</sub> | CID 568831 - PubChem [\[pubchem.ncbi.nlm.nih.gov\]](http://pubchem.ncbi.nlm.nih.gov)
- 4. Phenyl cyclohexanecarboxylate | C<sub>13</sub>H<sub>16</sub>O<sub>2</sub> | CID 557923 - PubChem [\[pubchem.ncbi.nlm.nih.gov\]](http://pubchem.ncbi.nlm.nih.gov)
- 5. [chem.libretexts.org](http://chem.libretexts.org) [\[chem.libretexts.org\]](http://chem.libretexts.org)
- 6. Diagnostic Fragmentation Pathways for Identification of Phthalate Metabolites in Non-Targeted Analysis Studies - PMC [\[pmc.ncbi.nlm.nih.gov\]](http://pmc.ncbi.nlm.nih.gov)
- 7. Benzyl Benzoate (CAS 120-51-4) - Chemical & Physical Properties by Cheméo [\[cheméo.com\]](http://cheméo.com)
- 8. Use of cyclodextrins as a cosmetic delivery system for fragrance materials: linalool and benzyl acetate - PubMed [\[pubmed.ncbi.nlm.nih.gov\]](http://pubmed.ncbi.nlm.nih.gov)

- [9. Collaborative Development of 2-Hydroxypropyl- \$\beta\$ -Cyclodextrin for the Treatment of Niemann-Pick Type C1 Disease - PMC \[pmc.ncbi.nlm.nih.gov\]](#)
- [10. Phenethyl acetate\(103-45-7\) MS spectrum \[chemicalbook.com\]](#)
- [11. tandfonline.com \[tandfonline.com\]](#)
- To cite this document: BenchChem. [Technical Comparison Guide: GC-MS Fragmentation Patterns of Benzyl Cycloheptanecarboxylate]. BenchChem, [2026]. [Online PDF]. Available at: [<https://www.benchchem.com/product/b2706540/docs#technical-comparison-guide-gc-ms-fragmentation-patterns-of-benzyl-cycloheptanecarboxylate>]

---

### Disclaimer & Data Validity:

The information provided in this document is for Research Use Only (RUO) and is strictly not intended for diagnostic or therapeutic procedures. While BenchChem strives to provide accurate protocols, we make no warranties, express or implied, regarding the fitness of this product for every specific experimental setup.

**Technical Support:** The protocols provided are for reference purposes. Unsure if this reagent suits your experiment?

**Need Industrial/Bulk Grade?** [Request Custom Synthesis Quote](#)

## BenchChem

Our mission is to be the trusted global source of essential and advanced chemicals, empowering scientists and researchers to drive progress in science and industry.

### Contact

Address: 3281 E Guasti Rd  
Ontario, CA 91761, United States  
Phone: (601) 213-4426  
Email: [info@benchchem.com](mailto:info@benchchem.com)

[Contact our Ph.D. Support Team for a compatibility check](#)

