

Troubleshooting unexpected oxidative dimerization in thienopyridines

Author: BenchChem Technical Support Team. **Date:** May 2026

Compound of Interest

Compound Name: *Thieno[2,3-b]pyridine-5-carboxylic acid*

CAS No.: *117390-38-2*

Cat. No.: *B2705886*

[Get Quote](#)

Technical Support Center: Thienopyridine Synthesis

Welcome to the technical support center for thienopyridine synthesis. This resource is designed for researchers, medicinal chemists, and process development scientists who are working with this important class of heterocyclic compounds. Thienopyridines are a cornerstone in medicinal chemistry, most notably as antiplatelet agents, but their synthesis can sometimes be hampered by unexpected side reactions.^[1]

One of the more challenging of these is oxidative dimerization, an unpredictable reaction that can significantly reduce the yield of the desired product and complicate purification. This guide provides in-depth troubleshooting strategies, frequently asked questions, and detailed protocols to help you diagnose, mitigate, and prevent this unwanted side reaction.

Frequently Asked Questions (FAQs)

Q1: What is oxidative dimerization in the context of thienopyridine synthesis?

A1: Oxidative dimerization is an intermolecular coupling reaction between two thienopyridine molecules, driven by an oxidizing agent. This results in the formation of a new carbon-carbon or carbon-nitrogen bond, leading to a dimeric byproduct with approximately double the molecular weight of the starting material. This can occur when the reaction conditions are favorable for the formation of reactive intermediates, such as radical cations or electrophilic species, that can then attack another thienopyridine molecule.

Q2: I've observed a significant amount of a high-molecular-weight impurity in my reaction. How can I confirm if it's a dimer?

A2: The most effective way to identify a suspected dimer is through Liquid Chromatography-Mass Spectrometry (LC-MS).[2][3][4] You should look for a mass peak that corresponds to approximately twice the mass of your starting thienopyridine, minus two hydrogen atoms (for a C-C or N-N linkage) or other leaving groups. Further structural confirmation can be obtained through isolation of the impurity using preparative HPLC, followed by detailed spectroscopic analysis, including ¹H NMR, ¹³C NMR, and 2D NMR techniques (COSY, HMBC, HSQC).[5]

Q3: What are the most common oxidizing agents that can cause dimerization?

A3: Strong oxidizing agents, particularly those that can act as electrophilic halogenating species, are often implicated. Sodium hypochlorite (NaOCl), the active ingredient in household bleach, has been shown to induce oxidative dimerization in certain 3-aminothienopyridine-2-carboxamides.[6] Other potent oxidants, such as peroxymonosulfate (Oxone), have also been reported to cause oxidative degradation of thienopyridines, which could potentially lead to dimerization under certain conditions.[7]

Q4: Can the substituents on my thienopyridine ring influence the likelihood of dimerization?

A4: Yes, the electronic properties of the substituents can play a significant role. Electron-donating groups (EDGs) on the thienopyridine ring, such as amino or alkoxy groups, can increase the electron density of the heterocyclic system, making it more susceptible to oxidation and subsequent dimerization. Conversely, electron-withdrawing groups (EWGs) can deactivate the ring towards oxidation, potentially suppressing this side reaction.

Q5: Are there any general precautions I can take to minimize the risk of oxidative dimerization?

A5: Absolutely. Working under an inert atmosphere, such as nitrogen or argon, can help to prevent unwanted oxidation from atmospheric oxygen. Additionally, using dry and degassed solvents is crucial, as trace amounts of water and oxygen can contribute to oxidative side reactions.

Troubleshooting Guide: Unexpected Dimer Formation

The appearance of a significant dimeric byproduct can be a frustrating obstacle. This guide provides a systematic approach to troubleshooting and resolving this issue.

Step 1: Confirm the Dimer Structure

Before attempting to modify your reaction conditions, it is crucial to confirm that the observed byproduct is indeed a dimer.

Protocol 1: LC-MS Analysis of Crude Reaction Mixture

- Sample Preparation: Dilute a small aliquot of your crude reaction mixture in a suitable solvent (e.g., acetonitrile or methanol).
- LC-MS Method:
 - Column: A C18 reversed-phase column is generally a good starting point.
 - Mobile Phase: A gradient of water and acetonitrile, both with 0.1% formic acid, is a common choice for good ionization.
 - Injection Volume: 1-5 μL .
 - MS Detector: Use an electrospray ionization (ESI) source in positive ion mode.
- Data Analysis:
 - Examine the mass spectrum for a peak at $[2M - 2H + H]^+$ or $[2M + H]^+$, where M is the molecular weight of your starting thienopyridine.

- The retention time of the dimer is typically longer than that of the monomer due to its larger size and increased hydrophobicity.

Step 2: Analyze the Reaction Conditions

Once the presence of a dimer is confirmed, a thorough review of your reaction parameters is necessary.

Parameter	Potential Cause of Dimerization	Recommended Action
Oxidizing Agent	Use of a harsh or non-selective oxidant (e.g., NaOCl).	Switch to a milder or more selective oxidizing agent. For S-oxidation, consider m-CPBA or MMPP. For other transformations, explore non-oxidative routes.
Solvent	Protic solvents (e.g., water, ethanol) can sometimes facilitate oxidative pathways.	Experiment with aprotic solvents such as dichloromethane (DCM), dioxane, or tetrahydrofuran (THF).
Temperature	Higher temperatures can accelerate side reactions.	Run the reaction at a lower temperature, even if it requires a longer reaction time.
Atmosphere	Presence of atmospheric oxygen.	Ensure the reaction is performed under a strict inert atmosphere (N ₂ or Ar).
pH	Basic or acidic conditions can influence the reactivity of the thienopyridine.	If possible, adjust the pH of the reaction mixture to be closer to neutral.

Step 3: Mitigating Dimerization in Oxidative Reactions

If an oxidative step is unavoidable in your synthetic route, the following strategies can help to suppress dimer formation.

Strategy 1: Choice of Oxidant

The choice of oxidizing agent is paramount. For instance, in the oxidation of 3-aminothieno[2,3-b]pyridine-2-carboxamides, switching from NaOCl to meta-chloroperoxybenzoic acid (m-CPBA) or magnesium monoperoxyphthalate (MMPP) can favor the formation of the S-oxide over the dimer.

Strategy 2: Control of Reaction Rate

Slow addition of the oxidizing agent can help to maintain a low concentration of reactive intermediates, thereby reducing the likelihood of intermolecular reactions.

Protocol 2: Slow Addition of Oxidant

- Dissolve your thienopyridine starting material in the chosen solvent and cool the mixture to the desired temperature (e.g., 0 °C).
- Dissolve the oxidizing agent in a separate flask with the same solvent.
- Using a syringe pump, add the oxidant solution to the thienopyridine solution dropwise over an extended period (e.g., 1-2 hours).
- Monitor the reaction progress by TLC or LC-MS to ensure complete consumption of the starting material without significant dimer formation.

Step 4: Alternative Non-Oxidative Synthetic Routes

In many cases, the most effective way to avoid oxidative dimerization is to choose a synthetic route that does not involve an oxidative step for the construction of the thienopyridine core.

Alternative Route 1: The Gewald Reaction

The Gewald reaction is a powerful one-pot synthesis of 2-aminothiophenes, which are versatile precursors to thienopyridines.^{[8][9][10][11][12]} This reaction involves the condensation of a ketone or aldehyde with an α -cyanoester in the presence of elemental sulfur and a base.

Diagram 1: The Gewald Reaction

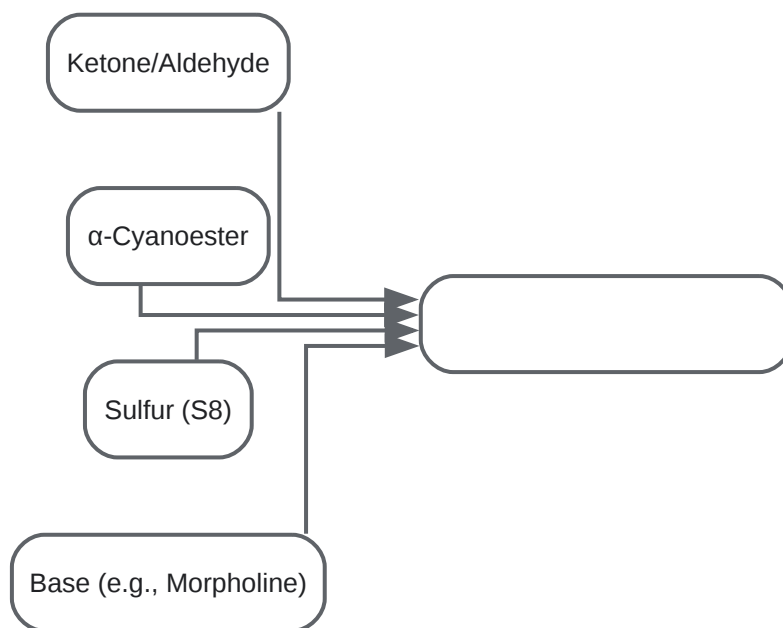

[Click to download full resolution via product page](#)

Caption: The Gewald reaction for 2-aminothiophene synthesis.

Alternative Route 2: The Friedländer Annulation

The Friedländer synthesis is a classic method for constructing quinoline and, by analogy, thienopyridine ring systems.^{[13][14][15][16]} This reaction involves the condensation of a 2-amino-3-carbonyl-substituted thiophene with a compound containing a reactive α -methylene group.

Diagram 2: The Friedländer Annulation for Thienopyridine Synthesis

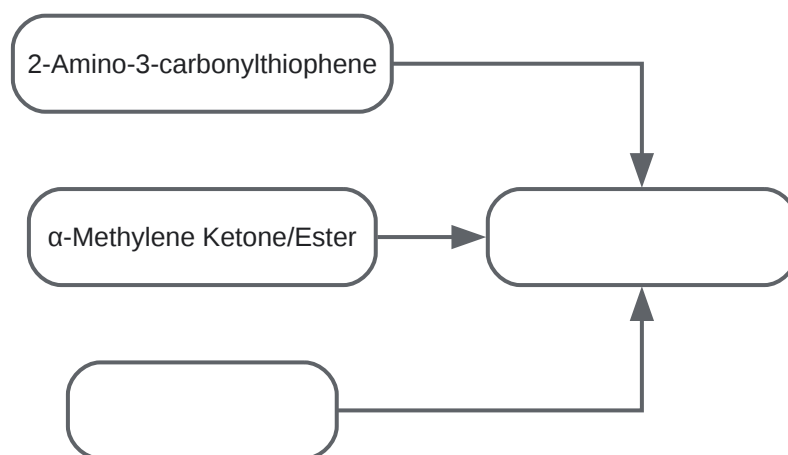

[Click to download full resolution via product page](#)

Caption: Friedländer annulation for thienopyridine synthesis.

By leveraging these troubleshooting strategies and considering alternative synthetic pathways, you can effectively overcome the challenge of unexpected oxidative dimerization and achieve a more efficient and reliable synthesis of your target thienopyridine compounds.

References

Need Custom Synthesis?

BenchChem offers custom synthesis for rare earth carbides and specific isotopic labeling.

Email: info@benchchem.com or [Request Quote Online](#).

Sources

- [1. researchgate.net \[researchgate.net\]](https://www.researchgate.net)
- [2. chimia.ch \[chimia.ch\]](https://www.chimia.ch)
- [3. cris.tau.ac.il \[cris.tau.ac.il\]](https://www.cris.tau.ac.il)
- [4. japsonline.com \[japsonline.com\]](https://www.japsonline.com)
- [5. Identification and characterization of a principal oxidation impurity in clopidogrel drug substance and drug product - PubMed \[pubmed.ncbi.nlm.nih.gov\]](https://pubmed.ncbi.nlm.nih.gov)

- 6. Sodium hypochlorite as a selective oxidant for organic compounds - Journal of the Chemical Society, Perkin Transactions 1 (RSC Publishing) [pubs.rsc.org]
- 7. Selective Oxidation of Clopidogrel by Peroxymonosulfate (PMS) and Sodium Halide (NaX) System: An NMR Study - PMC [pubmed.ncbi.nlm.nih.gov]
- 8. Synthesis and characterization of 2-aminothiophene derivatives by Gewald reaction [kr.cup.edu.in]
- 9. researchgate.net [researchgate.net]
- 10. Gewald reaction - Wikipedia [en.wikipedia.org]
- 11. researchgate.net [researchgate.net]
- 12. quod.lib.umich.edu [quod.lib.umich.edu]
- 13. researchgate.net [researchgate.net]
- 14. Friedländer synthesis - Wikipedia [en.wikipedia.org]
- 15. Friedlaender Synthesis [organic-chemistry.org]
- 16. researchgate.net [researchgate.net]
- To cite this document: BenchChem. [Troubleshooting unexpected oxidative dimerization in thienopyridines]. BenchChem, [2026]. [Online PDF]. Available at: [<https://www.benchchem.com/product/b2705886/docs#troubleshooting-unexpected-oxidative-dimerization-in-thienopyridines>]

Disclaimer & Data Validity:

The information provided in this document is for Research Use Only (RUO) and is strictly not intended for diagnostic or therapeutic procedures. While BenchChem strives to provide accurate protocols, we make no warranties, express or implied, regarding the fitness of this product for every specific experimental setup.

Technical Support: The protocols provided are for reference purposes. Unsure if this reagent suits your experiment?

Need Industrial/Bulk Grade? [Request Custom Synthesis Quote](#)

BenchChem

Our mission is to be the trusted global source of essential and advanced chemicals, empowering scientists and researchers to drive progress in science and industry.

Contact

Address: 3281 E Guasti Rd

Ontario, CA 91761, United States

Phone: (601) 213-4426

Email: info@benchchem.com

[Contact our Ph.D. Support Team for a compatibility check](#)