

Technical Guide: ¹H NMR Characterization of 4-Chloropyridine-2,5-Dicarboxylic Acid

Author: BenchChem Technical Support Team. **Date:** May 2026

Compound of Interest

Compound Name:	4-Chloropyridine-2,5-dicarboxylic acid
CAS No.:	1227945-07-4
Cat. No.:	B2705322

[Get Quote](#)

Executive Summary

4-Chloropyridine-2,5-dicarboxylic acid is a critical heterocycle used as a linker in Metal-Organic Frameworks (MOFs) and a scaffold in pharmaceutical synthesis. Its ¹H NMR spectrum is distinct but often misinterpreted due to the strong deshielding effects of the pyridine nitrogen and the two carboxyl groups.

The "Fingerprint" at a Glance:

- Solvent of Choice: DMSO-d₆ (for protonated form) or D₂O/NaOD (for dianion).
- Key Features: Two distinct singlets in the aromatic region (approx.[1] 8.0–9.5 ppm).[2]
- Differentiation: Unlike its symmetric isomer (4-chloro-2,6-dicarboxylic acid), which displays a single aromatic signal, the 2,5-isomer displays asymmetry, providing two resolved peaks of equal integration.

Theoretical Framework & Spectral Assignment

The ^1H NMR spectrum of **4-chloropyridine-2,5-dicarboxylic acid** is governed by the electron-deficient nature of the pyridine ring, further exacerbated by three electron-withdrawing groups: the nitrogen atom, two carboxylic acids (-COOH), and the chlorine atom (-Cl).

Predicted & Observed Shifts (DMSO-d6)

In DMSO-d6, the molecule exists in its protonated dicarboxylic acid form. The lack of symmetry results in two unique aromatic proton environments: H6 and H3.

Proton	Position	Multiplicity	Approx.[2] [3][4][5][6] [7] Shift (, ppm)	Integration	Structural Cause
H6	to N, to COOH	Singlet (s)	9.10 – 9.30	1H	Most deshielded due to proximity to electronegative Nitrogen and the anisotropic effect of the C5-COOH.
H3	to N, to COOH	Singlet (s)	8.30 – 8.50	1H	Deshielded by C2-COOH and ortho-Cl, but less than H6 because it is further from the ring Nitrogen.
-COOH	Positions 2, 5	Broad (br s)	13.0 – 14.5	2H	Highly acidic protons; chemical shift varies heavily with concentration and water content.

“

Technical Insight: Although H3 and H6 are para to each other, the coupling constant (

) is typically negligible (< 0.5 Hz) on standard 300/400 MHz instruments, resulting in sharp singlets.

Structural Logic Diagram

The following diagram illustrates the assignment logic based on electronic environments.

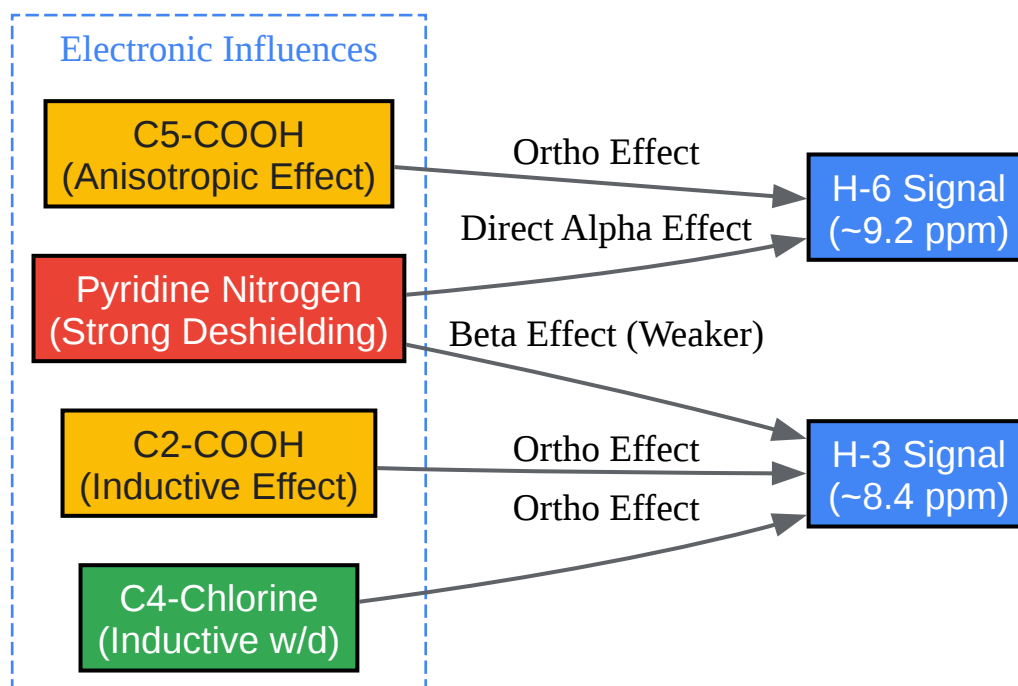

[Click to download full resolution via product page](#)

Figure 1: Correlation between structural substituents and observed chemical shifts. H6 is significantly more deshielded due to the alpha-nitrogen effect.

Comparative Analysis: Alternatives & Isomers

In drug development and ligand synthesis, "performance" equates to the ability to distinguish the target molecule from impurities, isomers, or precursors.

Distinguishing from the Symmetric Isomer (4-Chloro-2,6-PDCA)

The 2,6-isomer is a common alternative or impurity. NMR is the definitive method for differentiation.

Feature	4-Chloro-2,5-PDCA (Target)	4-Chloro-2,6-PDCA (Alternative)
Symmetry	Asymmetric ()	Symmetric ()
Aromatic Signals	Two distinct singlets (1H each)	One singlet (2H intensity)
Chemical Shift	Large gap (ppm)	Single peak at ppm
Conclusion	Resolved Regioisomer	Symmetric Regioisomer

Distinguishing from Precursor (4-Hydroxy-2,5-PDCA)

Synthesis often involves chlorinating the 4-hydroxy derivative (chelidamic acid analog) using

- Precursor (4-OH): Often exists as a pyridone tautomer. The ring protons are significantly more shielded (shifted upfield, often < 8.0 ppm) due to the electron-donating nature of the oxygen/nitrogen lone pair interaction.
- Product (4-Cl): The disappearance of the broad OH/NH signals and the downfield shift of the aromatic protons confirm successful chlorination.

Solvent Selection & Experimental Protocol

Solubility is the primary challenge with pyridine dicarboxylic acids. They are zwitterionic and insoluble in non-polar solvents like

Solvent Performance Comparison

Solvent	Suitability	Spectral Characteristics	Recommendation
DMSO-d6	High	Sharp peaks; COOH protons usually visible (broad).	Standard for Characterization.
D2O + NaOD	High	Soluble as dianion. Peaks shift upfield (shielding by). No COOH signal visible (exchange).	Best for Quantitative Purity Assays.
Methanol-d4	Medium	Moderate solubility. COOH protons exchange (disappear).	Alternative if DMSO is difficult to remove.
CDCl3	Fail	Insoluble.	Do Not Use.

Step-by-Step Protocol (DMSO-d6)

- Preparation: Weigh 10–15 mg of dried **4-chloropyridine-2,5-dicarboxylic acid**.
- Dissolution: Add 0.6 mL of DMSO-d6 (99.9% D).
 - Note: If the sample is cloudy, mild sonication (30s) is preferred over heating to avoid decarboxylation.
- Acquisition:
 - Scans: 16–32 (sufficient for >10 mg).
 - Relaxation Delay (D1): Set to

seconds. Carboxyl protons have long T1 relaxation times; insufficient delay will affect integration accuracy.

- Spectral Width: -2 to 16 ppm (to capture COOH).
- Processing:
 - Reference DMSO residual peak to 2.50 ppm.
 - Apply 0.3 Hz line broadening (LB) if signal-to-noise is low.

Workflow Visualization

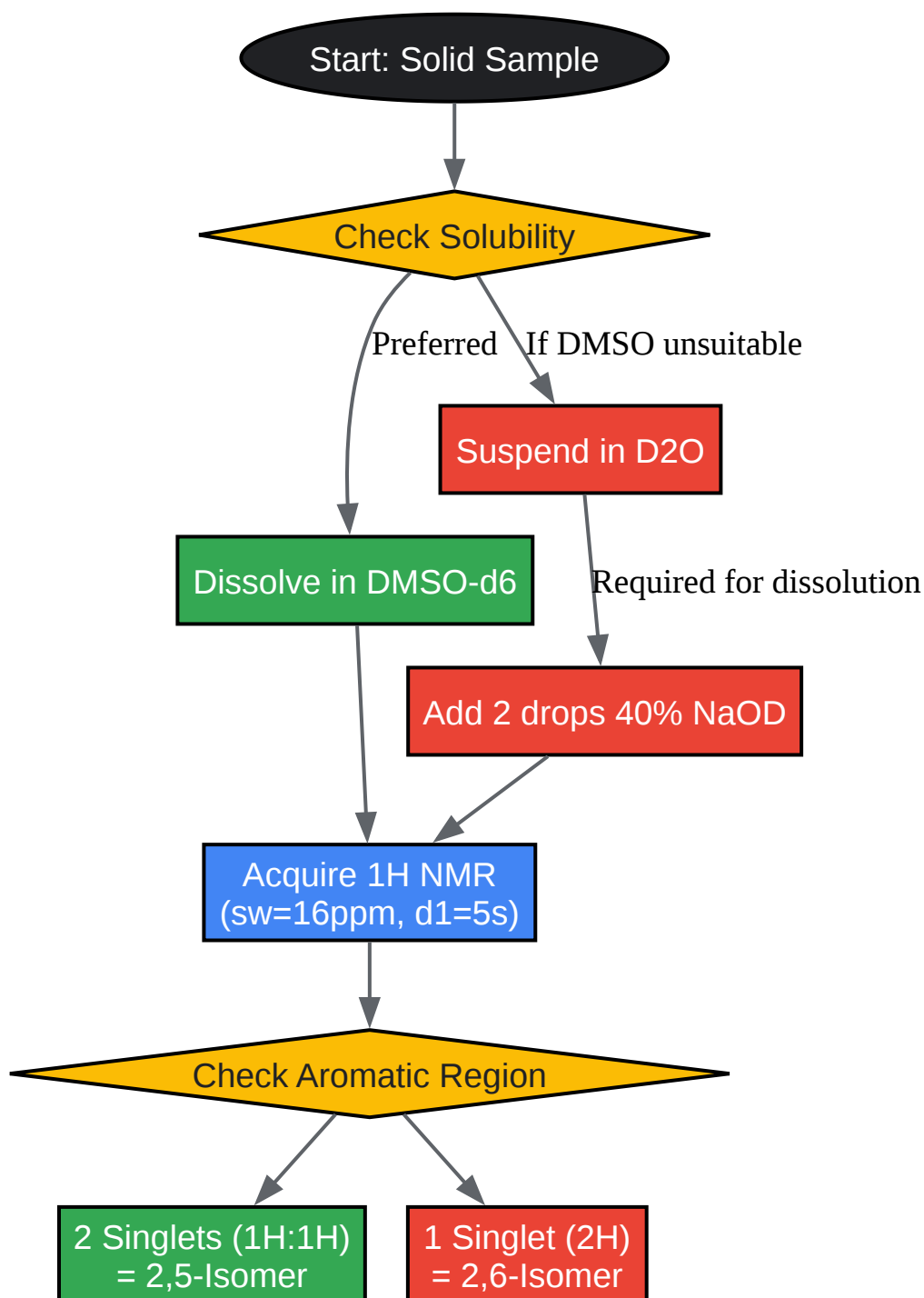

[Click to download full resolution via product page](#)

Figure 2: Decision tree for solvent selection and isomer confirmation.

Troubleshooting & Artifacts

- Water Peak Interference: In DMSO-d6, water appears at ~3.33 ppm.[7] However, the acidic COOH groups can catalyze proton exchange, broadening the water peak or shifting it downfield.
- Invisible Carboxyls: If the sample is "wet" (contains H2O), the COOH protons (13-14 ppm) may exchange rapidly with water and disappear or merge into a very broad hump in the baseline. This does not indicate impurity.
- Decarboxylation: Prolonged heating in DMSO can lead to thermal decarboxylation. If new peaks appear at ~8.6 ppm (monocarboxylic derivatives), discard the sample.

References

- Gottlieb, H. E., Kotlyar, V., & Nudelman, A. (1997).[8] NMR Chemical Shifts of Common Laboratory Solvents as Trace Impurities. *The Journal of Organic Chemistry*, 62(21), 7512–7515. [[Link](#)]
- Spivey, A. C., & Cernindak, R. (2005). Pyridine Synthesis via Electrophilic Substitution. *S. M. S. Science of Synthesis*, Vol 15.
- SDBS. (n.d.). Spectral Database for Organic Compounds, SDBS. National Institute of Advanced Industrial Science and Technology (AIST). (General reference for pyridine derivative shifts). [[Link](#)]

Need Custom Synthesis?

BenchChem offers custom synthesis for rare earth carbides and specific isotopic labeling.

Email: info@benchchem.com or [Request Quote Online](#).

Sources

- 1. nmr.oxinst.com [nmr.oxinst.com]
- 2. [Pyridine-2,6-dicarboxylic acid\(499-83-2\) 1H NMR](http://m.chemicalbook.com) [m.chemicalbook.com]
- 3. chemistryconnected.com [chemistryconnected.com]
- 4. web.pdx.edu [web.pdx.edu]

- [5. 4-chloropyridine\(626-61-9\) 1H NMR \[m.chemicalbook.com\]](#)
- [6. research.cbc.osu.edu \[research.cbc.osu.edu\]](#)
- [7. NMR Chemical Shifts of Impurities \[sigmaaldrich.com\]](#)
- [8. scs.illinois.edu \[scs.illinois.edu\]](#)
- To cite this document: BenchChem. [Technical Guide: 1H NMR Characterization of 4-Chloropyridine-2,5-Dicarboxylic Acid]. BenchChem, [2026]. [Online PDF]. Available at: [\[https://www.benchchem.com/product/b2705322/docs#technical-guide-1h-nmr-characterization-of-4-chloropyridine-2-5-dicarboxylic-acid\]](https://www.benchchem.com/product/b2705322/docs#technical-guide-1h-nmr-characterization-of-4-chloropyridine-2-5-dicarboxylic-acid)

Disclaimer & Data Validity:

The information provided in this document is for Research Use Only (RUO) and is strictly not intended for diagnostic or therapeutic procedures. While BenchChem strives to provide accurate protocols, we make no warranties, express or implied, regarding the fitness of this product for every specific experimental setup.

Technical Support: The protocols provided are for reference purposes. Unsure if this reagent suits your experiment?

Need Industrial/Bulk Grade? [Request Custom Synthesis Quote](#)

BenchChem

Our mission is to be the trusted global source of essential and advanced chemicals, empowering scientists and researchers to drive progress in science and industry.

Contact

Address: 3281 E Guasti Rd
Ontario, CA 91761, United States
Phone: (601) 213-4426
Email: info@benchchem.com

[Contact our Ph.D. Support Team for a compatibility check](#)

