

optimizing amide bond formation for electron-deficient anilines

Author: BenchChem Technical Support Team. **Date:** May 2026

Compound of Interest

Compound Name: *N*-(3,5-dichlorophenyl)-3-methylbenzamide

Cat. No.: B270707

[Get Quote](#)

Technical Support Guide: Optimizing Amide Bond Formation for Electron-Deficient Anilines

Case ID: AMIDE-OPT-2024 Subject: High-Throughput & Scale-Up Solutions for Low-Nucleophilicity Amines Support Level: Tier 3 (Senior Application Scientist)

The Core Challenge: The "Dead" Nucleophile

You are likely reading this because your standard EDC/HOBt or even HATU coupling failed. The issue is rarely the carboxylic acid activation; it is the aniline's nucleophilicity.

Anilines with electron-withdrawing groups (EWGs) like

,

,

, or multiple halogens often have a conjugate acid

below 2.0 (compared to ~4.6 for unsubstituted aniline). The nitrogen lone pair is heavily delocalized into the aromatic ring, rendering it chemically "invisible" to standard active esters.

The Solution Strategy: You cannot force the amine to be more reactive without altering the molecule. Therefore, you must increase the electrophilicity of the acyl donor to a level that compensates for the amine's lethargy.

Reagent Selection Matrix (The "Hardware")

Do not guess. Use this selection logic based on your substrate's electronic and steric profile.

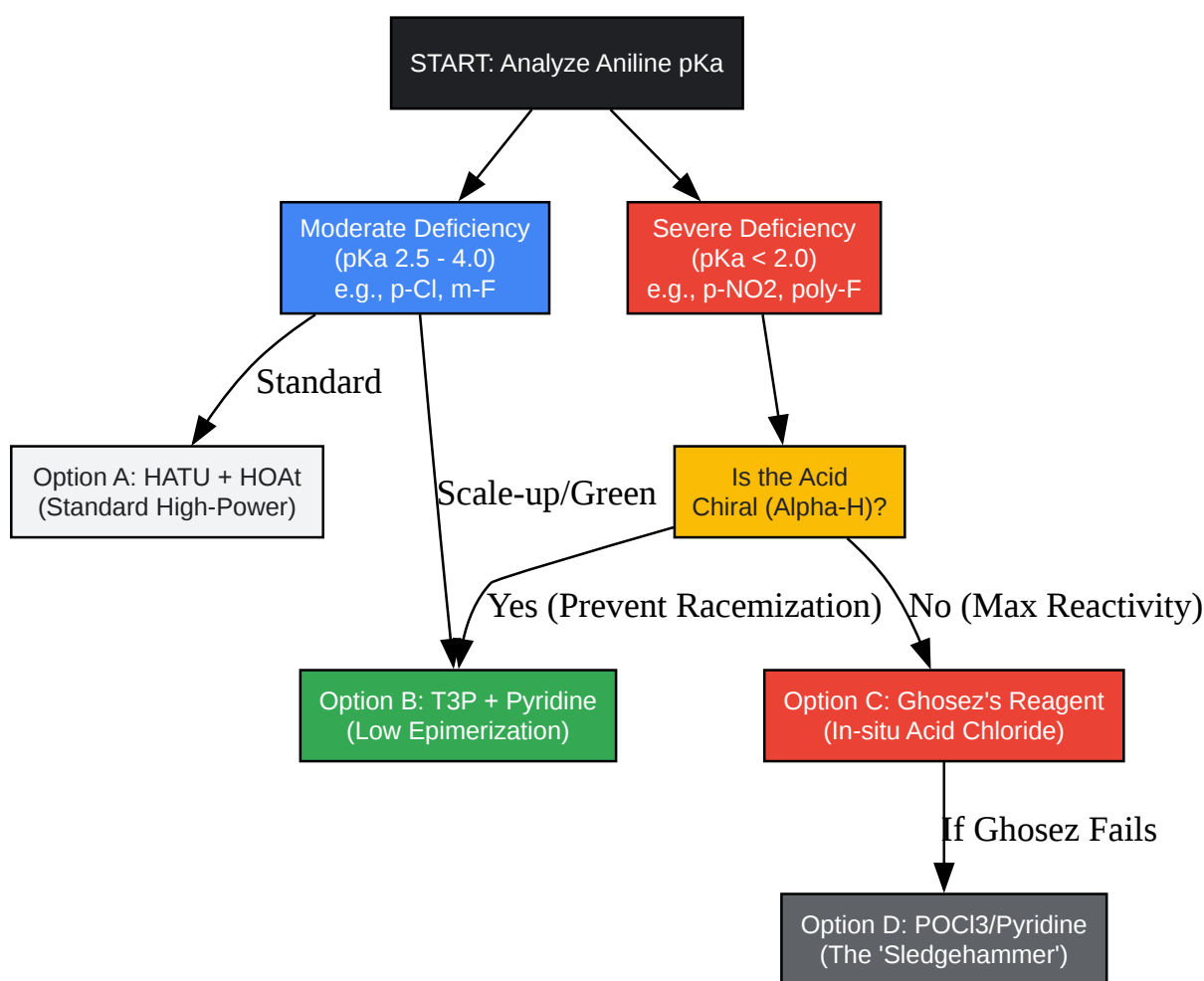

[Click to download full resolution via product page](#)

Figure 1: Decision matrix for coupling reagent selection based on aniline nucleophilicity and acid sensitivity.

Detailed Protocols

Protocol A: T3P (Propylphosphonic Anhydride) Coupling

Best for: Chiral acids, scale-up, and moderately deactivated anilines.[1] Why: T3P acts as a water scavenger, driving the equilibrium toward the amide. The byproduct is water-soluble, simplifying purification.[1][2][3]

- Stoichiometry: Acid (1.0 equiv), Aniline (1.1 equiv), Base (3.0–5.0 equiv), T3P (1.5–2.0 equiv, usually 50% w/w in EtOAc/DMF).
- Solvent: EtOAc (preferred for workup), Me-THF, or DMF (for solubility).
- Base Selection: Pyridine is superior to DIPEA/TEA for T3P couplings. It minimizes epimerization and acts as an efficient acyl transfer catalyst [1].
- Procedure:
 - Dissolve Acid and Aniline in the solvent.
 - Add Pyridine.[2][4][5] Cool to 0 °C.
 - Add T3P solution dropwise.
 - Allow to warm to RT.[4] Critical: If reaction is slow, heat to 50–60 °C. T3P is thermally stable, unlike HATU/EDC.
 - Workup: Wash with water, then 0.5M HCl, then NaHCO₃. The T3P byproducts wash away in the aqueous phase.[2]

Protocol B: Ghosez's Reagent (In-Situ Acid Chloride)

Best for: "Dead" anilines (

) and acid-sensitive substrates. Why: Converts acid to acid chloride under neutral conditions without generating HCl gas (unlike

).

- Reagent: 1-Chloro-N,N,2-trimethylpropenylamine (Ghosez's Reagent).

- Procedure:
 - Dissolve Carboxylic Acid (1.0 equiv) in dry DCM or CHCl₃.
 - Add Ghosez's Reagent (1.1–1.2 equiv) at 0 °C.
 - Stir at RT for 1–2 hours. (Monitor by TLC: Acid spot should disappear; quench an aliquot with MeOH to check for methyl ester formation).
 - Crucial Step: Once acid chloride is formed, add the Aniline (1.0–1.2 equiv) and Pyridine (2.0 equiv).
 - Reflux may be required for extremely electron-deficient anilines.

Troubleshooting Center (FAQs)

Q1: My reaction stalls at the "Active Ester" stage (seen on LCMS). Why?

- Diagnosis: The activation worked (HATU/T3P formed the intermediate), but the aniline is too weak to displace the leaving group.
- Fix:
 - Switch Mechanism: Move from Active Esters (HATU) to Acid Chlorides (Ghosez or). The chloride is a better leaving group than the OBt/OAt ester.
 - Catalysis: If using EDC/DCC, you must use DMAP (4-dimethylaminopyridine). DMAP forms a highly reactive N-acyl-pyridinium intermediate. Warning: DMAP causes racemization.

Q2: I see significant epimerization (racemization) of my chiral acid.

- Cause: Strong bases (TEA/DIPEA) or high heat promote proton abstraction at the alpha-position via the oxazolone pathway.
- Fix:

- Switch Base: Use Collidine (TMP) or Pyridine. They are weaker bases but sufficient to buffer the reaction.
- Use T3P: T3P/Pyridine is the gold standard for retaining chirality [2].
- Avoid DMAP: It is a notorious racemization agent.

Q3: The aniline is sterically hindered (ortho-substituted) AND electron-deficient.

- Fix: This is the "worst-case" scenario.
 - Use Microwave Irradiation (100–120 °C) with T3P in a sealed vessel.
 - If that fails, use the Merck Protocol (POCl₃/Pyridine): Dissolve acid and amine in pyridine, cool to -15 °C, add
. This generates a highly reactive phosphoryl chloride intermediate [3].

Mechanistic Insight

Understanding the T3P cycle helps explain why it works when EDC fails. It does not just "activate"; it chemically dehydrates the system.

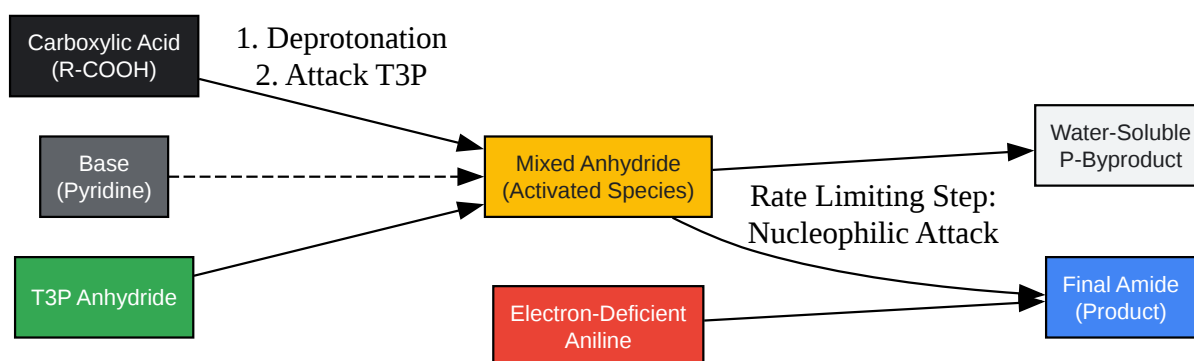

[Click to download full resolution via product page](#)

Figure 2: T3P activation pathway. The cyclic anhydride structure of T3P releases high energy upon ring-opening, driving the reaction forward.

Data Summary: Reagent Comparison

Feature	HATU / HOAt	T3P (Propylphosphonic anhydride)	Ghosez's Reagent
Reactivity	High	High	Very High (Acid Chloride)
Epimerization	Moderate	Very Low	Low (if neutral)
Moisture Sensitivity	Moderate	Low (Scavenger)	High
Workup	Chromatography often needed	Wash & Go (Aqueous)	Evaporation required
Safety	Explosive risk (HOBt/HOAt)	Safe (Stable liquid)	Corrosive
Cost	High	Moderate/Low (Bulk)	Moderate

References

- Dunetz, J. R., et al. (2011).^{[1][5]} "General and Scalable Amide Bond Formation with Epimerization-Prone Substrates Using T3P and Pyridine." *Organic Letters*.
- Montalbetti, C. A., & Falque, V. (2005).^{[6][7][8][9]} "Amide bond formation and peptide coupling."^{[2][9][10][11][12]} *Tetrahedron*.
- Valeur, E., & Bradley, M. (2009).^[9] "Amide bond formation: beyond the myth of coupling reagents." *Chemical Society Reviews*.^[9]

Need Custom Synthesis?

BenchChem offers custom synthesis for rare earth carbides and specific isotopic labeling.

Email: info@benchchem.com or [Request Quote Online](#).

Sources

- [1. General and Scalable Amide Bond Formation with Epimerization-Prone Substrates Using T3P and Pyridine \[organic-chemistry.org\]](#)
- [2. pub-mediabox-storage.rxweb-prd.com \[pub-mediabox-storage.rxweb-prd.com\]](#)
- [3. files01.core.ac.uk \[files01.core.ac.uk\]](#)
- [4. growingscience.com \[growingscience.com\]](#)
- [5. Amide synthesis by acylation \[organic-chemistry.org\]](#)
- [6. mch.estranky.sk \[mch.estranky.sk\]](#)
- [7. semanticscholar.org \[semanticscholar.org\]](#)
- [8. Montalbetti, C.A.G.N. and Falque, V. \(2005\) Amide Bond Formation and Peptide Coupling. Tetrahedron, 61, 10827-10852. - References - Scientific Research Publishing \[scirp.org\]](#)
- [9. books.rsc.org \[books.rsc.org\]](#)
- [10. pubs.rsc.org \[pubs.rsc.org\]](#)
- [11. researchgate.net \[researchgate.net\]](#)
- [12. Synthesis of amide derivatives for electron deficient amines and functionalized carboxylic acids using EDC and DMAP and a catalytic amount of HOBt as the coupling reagents - PMC \[pmc.ncbi.nlm.nih.gov\]](#)
- To cite this document: BenchChem. [optimizing amide bond formation for electron-deficient anilines]. BenchChem, [2026]. [Online PDF]. Available at: [\[https://www.benchchem.com/product/b270707/docs#optimizing-amide-bond-formation-for-electron-deficient-anilines\]](https://www.benchchem.com/product/b270707/docs#optimizing-amide-bond-formation-for-electron-deficient-anilines)

Disclaimer & Data Validity:

The information provided in this document is for Research Use Only (RUO) and is strictly not intended for diagnostic or therapeutic procedures. While BenchChem strives to provide accurate protocols, we make no warranties, express or implied, regarding the fitness of this product for every specific experimental setup.

Technical Support: The protocols provided are for reference purposes. Unsure if this reagent suits your experiment?

Need Industrial/Bulk Grade? [Request Custom Synthesis Quote](#)

BenchChem

Our mission is to be the trusted global source of essential and advanced chemicals, empowering scientists and researchers to drive progress in science and industry.

Contact

Address: 3281 E Guasti Rd

Ontario, CA 91761, United States

Phone: (601) 213-4426

Email: info@benchchem.com

[Contact our Ph.D. Support Team for a compatibility check](#)