

# The Multifaceted Biological Activities of Naphthalene-Sulfonamide Derivatives: A Technical Guide

**Author:** BenchChem Technical Support Team. **Date:** December 2025

## Compound of Interest

Compound Name: *6-amino-N-methylnaphthalene-2-sulfonamide*

Cat. No.: B027922

[Get Quote](#)

For Researchers, Scientists, and Drug Development Professionals

Naphthalene-sulfonamide derivatives have emerged as a versatile and privileged scaffold in medicinal chemistry, demonstrating a broad spectrum of biological activities. This technical guide provides an in-depth overview of the core biological activities of these compounds, with a focus on their anticancer, antimicrobial, and enzyme-inhibiting properties. This document summarizes key quantitative data, details relevant experimental protocols, and visualizes associated signaling pathways and workflows to serve as a comprehensive resource for researchers in the field.

## Anticancer Activity

Naphthalene-sulfonamide derivatives have shown significant promise as anticancer agents, exhibiting cytotoxicity against various cancer cell lines. Their mechanisms of action are diverse and often involve the inhibition of key signaling pathways and enzymes crucial for cancer cell proliferation and survival.

A notable mechanism of action for some naphthalene-sulfonamide hybrids is the modulation of the IL-6/JAK2/STAT3 signaling pathway.<sup>[1][2][3]</sup> This pathway is often dysregulated in cancer, contributing to tumor growth and proliferation.<sup>[3]</sup> Certain derivatives have been shown to downregulate the expression of key proteins in this pathway, including IL6, JAK2, and STAT3,

as well as downstream targets like BCL2, Cyclin D1, and c-MYC, while upregulating the pro-apoptotic protein BAX.[1][4]

Another anticancer mechanism exhibited by this class of compounds is the inhibition of tubulin polymerization.[5][6] Microtubules are essential for cell division, and their disruption can lead to cell cycle arrest in the G2/M phase and subsequent apoptosis.[5] Specific naphthalene-sulfonamide derivatives have been identified as microtubule-destabilizing agents that bind to the colchicine-binding site of tubulin.[5]

## Table 1: Anticancer Activity of Naphthalene-Sulfonamide Derivatives

| Compound ID                                                         | Cancer Cell Line | IC50 ( $\mu\text{M}$ ) | Reference |
|---------------------------------------------------------------------|------------------|------------------------|-----------|
| Series 1: 6-acetylnaphthalene-2-sulfonamide derivatives             |                  |                        |           |
| 5a                                                                  | MCF7 (Breast)    | 10.23                  | [3]       |
| 5b                                                                  | MCF7 (Breast)    | 8.58                   | [3]       |
| 5e                                                                  | MCF7 (Breast)    | 9.01                   | [3]       |
| 5i                                                                  | MCF7 (Breast)    | 9.39                   | [3]       |
| Series 2: Naphthalene-sulfonamide tubulin polymerization inhibitors |                  |                        |           |
| 5c                                                                  | MCF-7 (Breast)   | $0.51 \pm 0.03$        | [5]       |
| 5c                                                                  | A549 (Lung)      | $0.33 \pm 0.01$        | [5]       |
| Comparative Drugs                                                   |                  |                        |           |
| Cisplatin                                                           | MCF-7 (Breast)   | $11.15 \pm 0.75$       | [5]       |
| 5-Fu                                                                | MCF-7 (Breast)   | $11.61 \pm 0.60$       | [5]       |
| Tamoxifen                                                           | MCF-7 (Breast)   | $14.28 \pm 0.40$       | [5]       |
| CA-4                                                                | MCF-7 (Breast)   | $5.55 \pm 0.11$        | [5]       |

## Antimicrobial Activity

The naphthalene-sulfonamide scaffold has also been explored for its antimicrobial properties, with derivatives showing activity against a range of bacteria and fungi.[1][2] The mechanism of action for their antimicrobial effects can involve the inhibition of essential bacterial enzymes like DNA gyrase and topoisomerase IV, which are crucial for DNA replication and repair.[1][2]

## Table 2: Antimicrobial Activity of Naphthalene-Sulfonamide Derivatives

| Compound ID                                             | Microorganism | MIC ( $\mu\text{g/mL}$ ) | Reference |
|---------------------------------------------------------|---------------|--------------------------|-----------|
| Series 1: 6-acetylnaphthalene-2-sulfonamide derivatives |               |                          |           |
| 5b                                                      | E. coli       | 10                       | [2]       |
| II                                                      | E. coli       | 12.5                     | [2]       |
| II                                                      | S. aureus     | 62.5                     | [2]       |

## Enzyme Inhibition

The versatility of the naphthalene-sulfonamide scaffold extends to the inhibition of various enzymes implicated in a range of diseases.

**STAT3 Inhibition:** As mentioned in the anticancer section, direct inhibition of STAT3 phosphorylation is a key mechanism for some derivatives.[1][2]

**Topoisomerase Inhibition:** Certain naphthalene-sulfonamide compounds have demonstrated potent inhibitory activity against bacterial topoisomerase IV and moderate inhibition of DNA gyrase.[1][2]

**Protein Kinase Inhibition:** Naphthalene-sulfonamides have been identified as protein kinase inhibitors, often acting as competitive inhibitors with respect to ATP.[7][8] This includes the inhibition of enzymes like smooth muscle myosin light chain kinase (MLC-kinase), cAMP-dependent protein kinase, and protein kinase C.[7]

**Carbonic Anhydrase Inhibition:** The sulfonamide moiety is a well-known pharmacophore for carbonic anhydrase inhibitors, and naphthalene-sulfonamide derivatives have been investigated for this activity.[5]

**Table 3: Enzyme Inhibitory Activity of Naphthalene-Sulfonamide Derivatives**

| Compound ID                              | Enzyme Target                 | IC50 / Ki              | Reference |
|------------------------------------------|-------------------------------|------------------------|-----------|
| STAT3<br>Phosphorylation<br>Inhibition   |                               |                        |           |
| 5e                                       | STAT3                         | 3.01 $\mu$ M (IC50)    | [1][2]    |
| 5b                                       | STAT3                         | 3.59 $\mu$ M (IC50)    | [1][2]    |
| Cryptotanshinone<br>(Reference)          | STAT3                         | 3.52 $\mu$ M (IC50)    | [1][2]    |
| Compound I                               | STAT3                         | 6.84 $\mu$ M (IC50)    | [2]       |
| Bacterial<br>Topoisomerase<br>Inhibition |                               |                        |           |
| 5b                                       | E. coli Topoisomerase<br>IV   | 5.3 $\mu$ g/mL (IC50)  | [1][2]    |
| Norfloxacin<br>(Reference)               | E. coli Topoisomerase<br>IV   | 8.24 $\mu$ g/mL (IC50) | [1][2]    |
| 5e                                       | S. aureus<br>Topoisomerase IV | 7.65 $\mu$ g/mL (IC50) | [1][2]    |
| Norfloxacin<br>(Reference)               | S. aureus<br>Topoisomerase IV | 7.07 $\mu$ g/mL (IC50) | [1][2]    |
| Tubulin<br>Polymerization<br>Inhibition  |                               |                        |           |
| 5c                                       | Tubulin                       | 2.8 $\mu$ M (IC50)     | [5][6]    |
| Protein Kinase<br>Inhibition             |                               |                        |           |
| A-3                                      | MLC-Kinase                    | 7.4 $\mu$ M (Ki)       | [7]       |

## Experimental Protocols

Detailed methodologies for the key experiments cited are provided below.

### MTT Assay for Cytotoxicity

This colorimetric assay measures cell viability by assessing the metabolic activity of mitochondrial dehydrogenases.

**Principle:** Metabolically active cells reduce the yellow tetrazolium salt, 3-(4,5-dimethylthiazol-2-yl)-2,5-diphenyltetrazolium bromide (MTT), to purple formazan crystals.<sup>[9][10]</sup> The amount of formazan produced is proportional to the number of viable cells and is quantified by measuring the absorbance of the solubilized crystals.<sup>[11][12]</sup>

**Procedure:**

- **Cell Seeding:** Seed cells in a 96-well plate at a density of  $5 \times 10^3$  to  $1 \times 10^4$  cells per well in 100  $\mu$ L of complete culture medium and allow them to adhere overnight.
- **Compound Treatment:** Replace the medium with fresh medium containing serial dilutions of the naphthalene-sulfonamide derivatives. Include a vehicle control (e.g., DMSO) and a blank (medium only). Incubate for a specified period (e.g., 24, 48, or 72 hours).
- **MTT Addition:** Add 10  $\mu$ L of MTT solution (5 mg/mL in PBS) to each well and incubate for 2-4 hours at 37°C.
- **Formazan Solubilization:** For adherent cells, carefully remove the MTT solution and add 100-150  $\mu$ L of a solubilization solution (e.g., DMSO) to each well.<sup>[11]</sup> For suspension cells, centrifuge the plate to pellet the cells before removing the supernatant and adding the solubilization solution.
- **Absorbance Measurement:** Shake the plate on an orbital shaker for 15 minutes to ensure complete dissolution of the formazan. Measure the absorbance at 570 nm using a microplate reader. A reference wavelength of 630 nm can be used for background subtraction.
- **Data Analysis:** Calculate the percentage of cell viability relative to the vehicle control and plot a dose-response curve to determine the IC<sub>50</sub> value.

## Agar Well Diffusion Assay for Antimicrobial Activity

This method is used to assess the antimicrobial activity of a substance by measuring the zone of growth inhibition.

**Principle:** The test compound diffuses from a well through a solid agar medium that has been uniformly inoculated with a test microorganism. The diameter of the zone of inhibition is proportional to the antimicrobial activity of the compound.<sup>[13][14][15]</sup>

**Procedure:**

- **Media Preparation:** Prepare Mueller-Hinton agar (MHA) for bacteria or a suitable medium for fungi and pour into sterile Petri plates.
- **Inoculum Preparation:** Prepare a standardized microbial inoculum with a turbidity equivalent to the 0.5 McFarland standard.
- **Inoculation:** Uniformly spread the microbial inoculum over the entire surface of the agar plate using a sterile cotton swab to create a lawn.
- **Well Creation:** Aseptically create wells (6-8 mm in diameter) in the agar using a sterile cork borer.
- **Compound Application:** Add a defined volume (e.g., 20-100  $\mu$ L) of the naphthalene-sulfonamide derivative solution at a specific concentration into the wells. Include positive (known antibiotic) and negative (solvent) controls.
- **Incubation:** Incubate the plates under appropriate conditions (e.g., 37°C for 24 hours for bacteria).
- **Zone of Inhibition Measurement:** After incubation, measure the diameter of the clear zone of growth inhibition around each well in millimeters.

## STAT3 Phosphorylation Inhibition Assay (Western Blot)

This assay directly assesses the ability of a compound to inhibit the phosphorylation of STAT3 in a cellular context.

Principle: Western blotting is used to detect the levels of phosphorylated STAT3 (p-STAT3) and total STAT3 in cell lysates after treatment with the test compound. A reduction in the p-STAT3/total STAT3 ratio indicates inhibition.

Procedure:

- Cell Culture and Treatment: Plate cells (e.g., MCF7) and allow them to adhere. Serum-starve the cells if necessary, then pre-treat with various concentrations of the naphthalene-sulfonamide inhibitor for a specified time.
- Stimulation: Stimulate the cells with a cytokine such as IL-6 (e.g., 20 ng/mL) for 15-30 minutes to induce STAT3 phosphorylation.
- Cell Lysis: Wash the cells with ice-cold PBS and lyse them using a suitable lysis buffer (e.g., RIPA buffer) containing protease and phosphatase inhibitors.
- Protein Quantification: Determine the protein concentration of the lysates using a BCA or similar protein assay.
- SDS-PAGE and Western Blotting:
  - Separate equal amounts of protein on an SDS-polyacrylamide gel.
  - Transfer the separated proteins to a PVDF membrane.
  - Block the membrane with a blocking buffer (e.g., 5% non-fat milk in TBST).
  - Incubate the membrane with primary antibodies specific for phospho-STAT3 (e.g., Tyr705) and total STAT3. A loading control antibody (e.g., GAPDH or  $\beta$ -tubulin) should also be used.
  - Wash the membrane and incubate with the appropriate HRP-conjugated secondary antibodies.
  - Detect the protein bands using an enhanced chemiluminescence (ECL) substrate and an imaging system.



- Data Analysis: Quantify the band intensities using densitometry software and normalize the p-STAT3 signal to the total STAT3 signal.

## Visualizations

### Signaling Pathways and Experimental Workflows

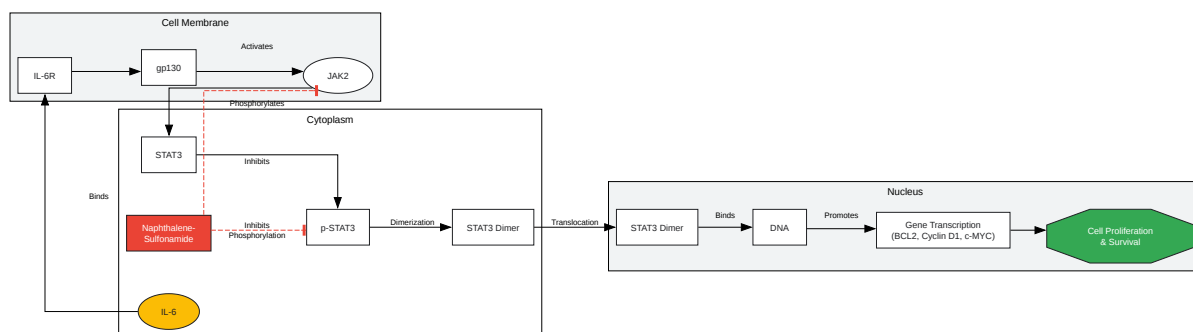

[Click to download full resolution via product page](#)

Caption: IL-6/JAK2/STAT3 signaling pathway and its inhibition by naphthalene-sulfonamide derivatives.

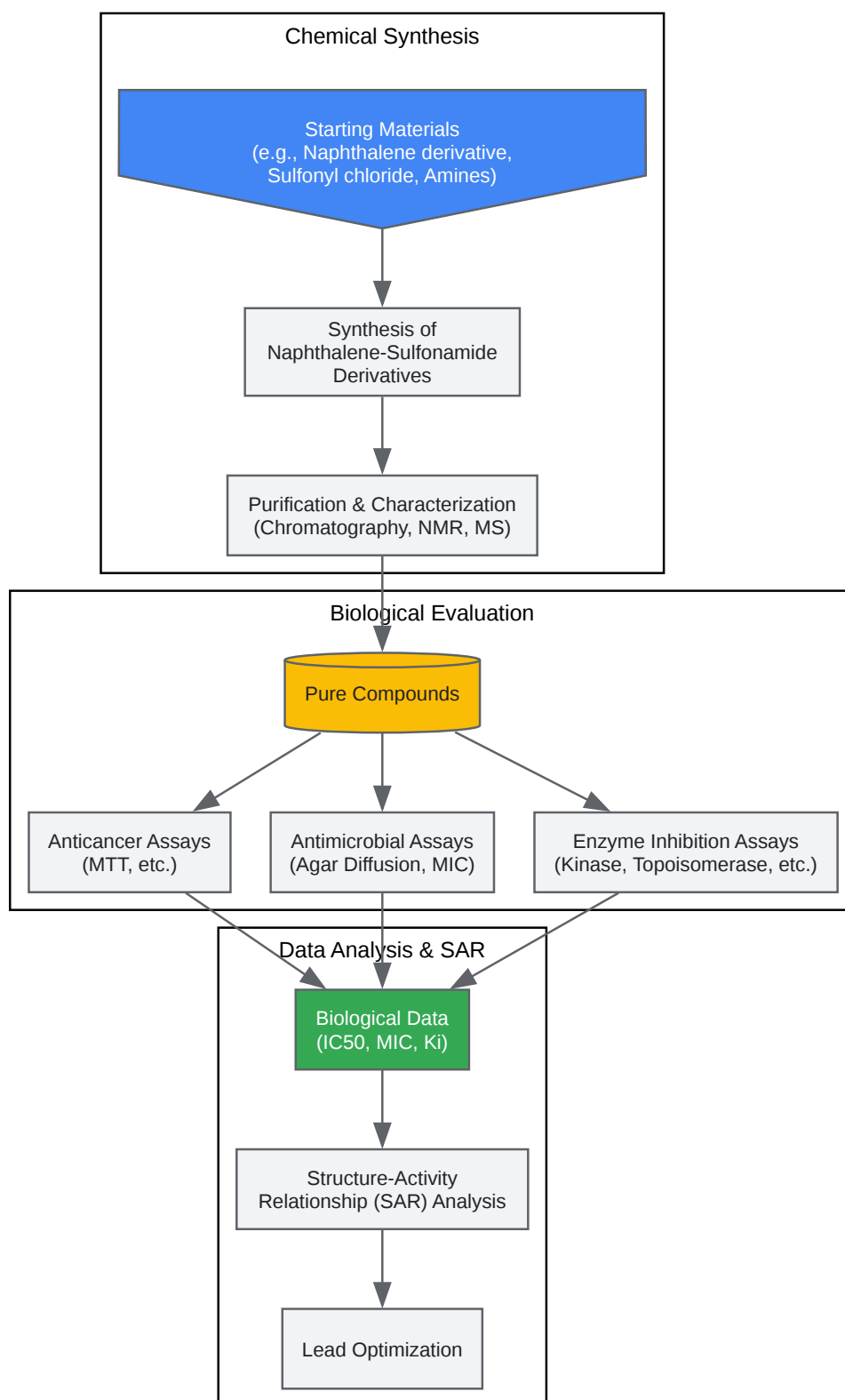

[Click to download full resolution via product page](#)

Caption: General experimental workflow for the synthesis and biological evaluation of naphthalene-sulfonamides.

Caption: Key structure-activity relationships (SAR) for naphthalene-sulfonamide derivatives.

### Need Custom Synthesis?

BenchChem offers custom synthesis for rare earth carbides and specific isotopic labeling.

Email: [info@benchchem.com](mailto:info@benchchem.com) or [Request Quote Online](#).

## References

- 1. Methods to assay inhibitors of DNA gyrase and topoisomerase IV activities - PubMed [pubmed.ncbi.nlm.nih.gov]
- 2. benchchem.com [benchchem.com]
- 3. Methods to Assay Inhibitors of DNA Gyrase and Topoisomerase IV Activities | Springer Nature Experiments [experiments.springernature.com]
- 4. academic.oup.com [academic.oup.com]
- 5. benchchem.com [benchchem.com]
- 6. benchchem.com [benchchem.com]
- 7. Cytotoxicity MTT Assay Protocols and Methods | Springer Nature Experiments [experiments.springernature.com]
- 8. chemistnotes.com [chemistnotes.com]
- 9. acmeresearchlabs.in [acmeresearchlabs.in]
- 10. m.youtube.com [m.youtube.com]
- 11. sigmaaldrich.com [sigmaaldrich.com]
- 12. High-throughput assays for DNA gyrase and other topoisomerases - PMC [pmc.ncbi.nlm.nih.gov]
- 13. Cell Viability Assays - Assay Guidance Manual - NCBI Bookshelf [ncbi.nlm.nih.gov]
- 14. Carbonic Anhydrase Activity Assay [protocols.io]
- 15. assaygenie.com [assaygenie.com]

- To cite this document: BenchChem. [The Multifaceted Biological Activities of Naphthalene-Sulfonamide Derivatives: A Technical Guide]. BenchChem, [2025]. [Online PDF]. Available at: [<https://www.benchchem.com/product/b027922#biological-activity-of-naphthalene-sulfonamide-derivatives>]

---

### Disclaimer & Data Validity:

The information provided in this document is for Research Use Only (RUO) and is strictly not intended for diagnostic or therapeutic procedures. While BenchChem strives to provide accurate protocols, we make no warranties, express or implied, regarding the fitness of this product for every specific experimental setup.

**Technical Support:** The protocols provided are for reference purposes. Unsure if this reagent suits your experiment? [[Contact our Ph.D. Support Team for a compatibility check](#)]

**Need Industrial/Bulk Grade?** [Request Custom Synthesis Quote](#)

## BenchChem

Our mission is to be the trusted global source of essential and advanced chemicals, empowering scientists and researchers to drive progress in science and industry.

### Contact

Address: 3281 E Guasti Rd

Ontario, CA 91761, United States

Phone: (601) 213-4426

Email: [info@benchchem.com](mailto:info@benchchem.com)