

Technical Support Center: Synthesis of 2-Iodo-3-methylbenzoic Acid

Author: BenchChem Technical Support Team. **Date:** May 2026

Compound of Interest

Compound Name: 2-Iodo-3-methylbenzoic acid

CAS No.: 108078-14-4

Cat. No.: B027227

[Get Quote](#)

Welcome to the technical support center for the synthesis of **2-Iodo-3-methylbenzoic acid**. This guide is designed for researchers, scientists, and drug development professionals to navigate the common challenges and troubleshoot byproduct formation during this synthesis. My aim is to provide not just solutions, but a deeper understanding of the underlying chemical principles to empower you in your experimental work.

Introduction to Synthetic Strategies

The synthesis of **2-Iodo-3-methylbenzoic acid** is primarily achieved through two main routes: the Sandmeyer reaction starting from 2-amino-3-methylbenzoic acid, and the direct electrophilic iodination of 3-methylbenzoic acid. Each pathway presents a unique set of challenges and potential byproducts. This guide will address specific issues you might encounter with a focus on the more common and often higher-yielding Sandmeyer approach, while also touching upon potential pitfalls of direct iodination.

Troubleshooting Guide & FAQs

Sandmeyer Reaction Route: Common Issues

The Sandmeyer reaction is a versatile method for introducing a variety of functional groups onto an aromatic ring via a diazonium salt intermediate.[1][2] However, the reactive nature of the diazonium salt can lead to several byproducts.

Answer:

The presence of 3-methylsalicylic acid (a phenol) is a classic byproduct of the Sandmeyer reaction when water is present and can react with the diazonium salt.

Causality: The diazonium salt intermediate is highly reactive and susceptible to nucleophilic attack. If water molecules are present in the reaction mixture, they can act as nucleophiles, leading to the formation of a phenol and the evolution of nitrogen gas. This is a common competitive side reaction.

Troubleshooting & Prevention:

- **Temperature Control:** Maintain a low temperature (typically 0-5 °C) during the diazotization step (formation of the diazonium salt from the amine with nitrous acid).[3] This increases the stability of the diazonium salt and minimizes its premature decomposition and reaction with water.
- **Anhydrous Conditions:** While the reaction is typically run in an aqueous acidic medium, minimizing excess water where possible is beneficial. Ensure your starting materials and solvents are of appropriate purity.
- **Controlled Addition of Iodide:** Add the potassium iodide solution slowly to the diazonium salt solution.[3] A slow, controlled addition ensures that the iodide ion is the predominant nucleophile available to react with the diazonium salt.

Corrective Action (Purification):

If you have already synthesized a batch with this impurity, you can often remove 3-methylsalicylic acid through careful recrystallization or column chromatography.

Answer:

The formation of dark, often polymeric or tar-like substances is frequently due to azo coupling reactions or other decomposition pathways of the diazonium salt.

Causality:

- **Azo Coupling:** The diazonium salt can act as an electrophile and react with an unreacted molecule of the starting material, 2-amino-3-methylbenzoic acid, or another electron-rich aromatic species in the reaction mixture. This leads to the formation of highly colored azo compounds.
- **Radical Reactions:** The Sandmeyer reaction proceeds through a radical mechanism.^{[1][4]} Uncontrolled radical reactions can lead to polymerization and the formation of complex, insoluble byproducts.

Troubleshooting & Prevention:

- **Stoichiometry:** Ensure complete conversion of the starting amine to the diazonium salt. The presence of unreacted amine is a primary cause of azo coupling. Use a slight excess of sodium nitrite and ensure it is added to an acidic solution of the amine.
- **pH Control:** Maintain a strongly acidic environment. This protonates the unreacted amine, deactivating it towards electrophilic attack by the diazonium salt.
- **Temperature Control:** As with phenol formation, low temperatures (0-5 °C) are crucial for minimizing decomposition and side reactions.

Answer:

This is a very pertinent issue, as the purity of your final product is highly dependent on the purity of your starting 2-amino-3-methylbenzoic acid. The synthesis of this starting material often involves the nitration of 3-methylbenzoic acid, which can be non-selective.

Source of Impurity:

The nitration of 3-methylbenzoic acid to form 2-nitro-3-methylbenzoic acid is a critical step. However, this reaction can produce other isomers such as 4-nitro-3-methylbenzoic acid and 6-nitro-3-methylbenzoic acid.^[5] These nitrated isomers will then be reduced to their

corresponding amines and subsequently iodinated, leading to a mixture of iodo-methylbenzoic acid isomers in your final product. It has been noted that existing nitration methods for m-toluic acid can result in many by-products and low selectivity.[5]

Troubleshooting & Prevention:

- **Starting Material Purity:** It is paramount to start with highly pure 2-amino-3-methylbenzoic acid. It is recommended to analyze the purity of your starting amine by techniques such as HPLC or NMR before proceeding with the Sandmeyer reaction.
- **Purification of the Amine:** If your starting amine is impure, consider purifying it by recrystallization.

Analytical Confirmation:

- **LC-MS:** This is an excellent technique to identify the presence of isomers, as they will have the same mass but different retention times.
- **¹H NMR:** Carefully analyze the aromatic region of the proton NMR spectrum. The different substitution patterns of the isomers will result in distinct splitting patterns and chemical shifts.

Direct Iodination Route: Key Challenge

Answer:

Yes, this is a well-documented challenge with the direct iodination of substituted benzoic acids.

Causality:

The directing effects of the methyl (-CH₃) and carboxylic acid (-COOH) groups on the aromatic ring influence the position of iodination. The methyl group is an ortho-, para-director, while the carboxylic acid group is a meta-director. This can lead to the formation of a mixture of mono-iodinated products, including the desired **2-iodo-3-methylbenzoic acid**, as well as other isomers like 4-iodo-3-methylbenzoic acid and 6-iodo-3-methylbenzoic acid. The separation of these regioisomers can be challenging due to their similar physical properties.[6][7]

Troubleshooting & Prevention:

- **Reaction Conditions:** While various catalysts and reaction conditions have been explored to improve regioselectivity, achieving perfect selectivity can be difficult.[8][9][10]
- **Alternative Route:** The Sandmeyer reaction, despite its own set of potential byproducts, often offers better regiochemical control, as the position of the iodo group is determined by the position of the amino group in the starting material.

Experimental Protocols

Protocol 1: Diazotization and Iodination of 2-amino-3-methylbenzoic acid (Sandmeyer Reaction)

- **Preparation of the Amine Solution:** In a three-necked flask equipped with a mechanical stirrer, a thermometer, and a dropping funnel, dissolve 2-amino-3-methylbenzoic acid in a suitable aqueous acid (e.g., dilute HCl or H₂SO₄). Cool the solution to 0-5 °C in an ice-salt bath.
- **Diazotization:** Prepare a solution of sodium nitrite in water. Add this solution dropwise to the cooled amine solution, ensuring the temperature remains below 5 °C. The addition should be slow enough to control the exothermic reaction.
- **Preparation of the Iodide Solution:** In a separate beaker, dissolve potassium iodide in water.
- **Iodination:** Slowly add the potassium iodide solution to the freshly prepared diazonium salt solution.[3] Continue stirring at 0-5 °C for a period, then allow the reaction to warm to room temperature and stir until nitrogen evolution ceases.
- **Work-up:** Quench any excess nitrous acid with urea or sulfamic acid. Decolorize the solution by adding a small amount of sodium thiosulfate.[3] The crude product can then be isolated by filtration.
- **Purification:** The crude product should be purified, for example, by recrystallization from a suitable solvent system (e.g., ethanol/water) to remove byproducts.

Protocol 2: Purity Analysis by High-Performance Liquid Chromatography (HPLC)

- Column: C18 reverse-phase column (e.g., 250 x 4.6 mm, 5 μ m).
- Mobile Phase: A gradient of methanol and water (with 0.1% formic acid or another suitable modifier) is often effective. For example, a starting condition of 50:50 methanol:water can be used.^[11]
- Flow Rate: 1.0 mL/min.
- Detection: UV detection at a suitable wavelength (e.g., 254 nm or 265 nm).^[11]
- Sample Preparation: Dissolve a small amount of your crude or purified product in the mobile phase or a suitable solvent.

Data Summary

Synthetic Route	Common Byproducts	Key Prevention Strategies
Sandmeyer Reaction	3-methylsalicylic acid, Azo compounds, Regioisomers from starting material	Strict temperature control (0-5°C), Purity of starting amine, Strong acid conditions
Direct Iodination	Regioisomers (e.g., 4-Iodo-3-methylbenzoic acid, 6-Iodo-3-methylbenzoic acid)	Use of regioselective catalysts, Consider Sandmeyer route for better control

Visualizing Reaction Pathways

Byproduct Formation in the Sandmeyer Synthesis of 2-Iodo-3-methylbenzoic Acid

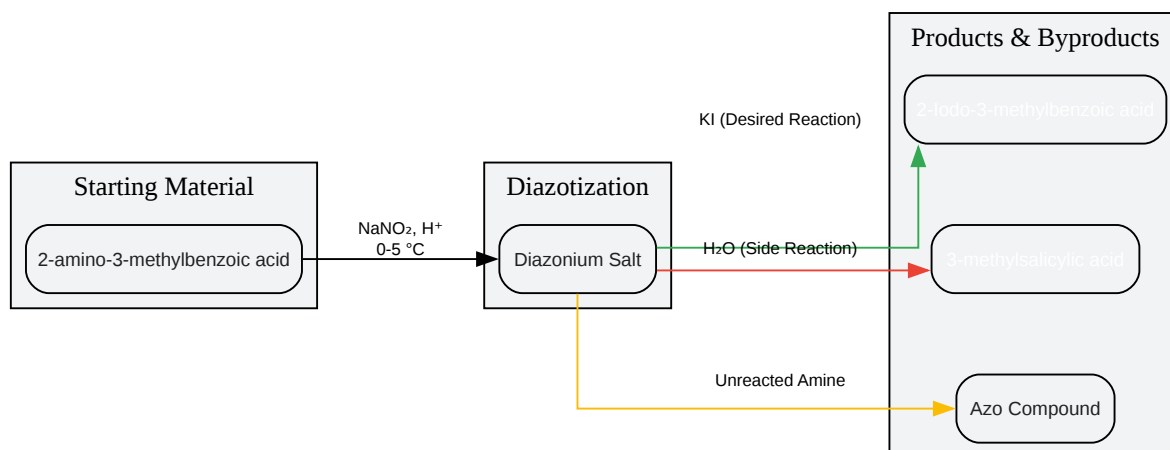

[Click to download full resolution via product page](#)

Caption: Key reaction pathways in the Sandmeyer synthesis.

Troubleshooting Logic for Impure Product

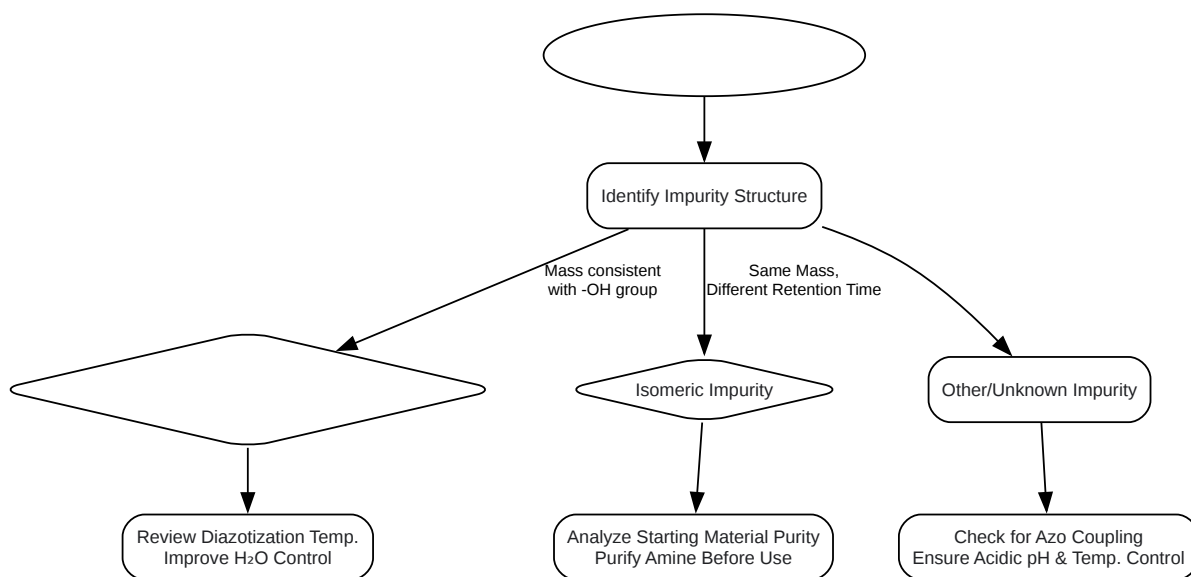

[Click to download full resolution via product page](#)

Caption: A logical workflow for troubleshooting impurities.

References

- Eureka | Patsnap. (n.d.). Method for preparing 2-amino-5-chloro-3-methylbenzoic acid.
- Google Patents. (n.d.). CN100406422C - Process for producing 5-iodo-2-methylbenzoic acid.
- Google Patents. (n.d.). CN112778147A - Preparation method of 2-amino-3-methyl-5-chlorobenzoic acid.
- Google Patents. (n.d.). CN111732520A - Preparation method of 3-methyl-2-aminobenzoic acid.
- EvitaChem. (n.d.). Buy **2-Iodo-3-methylbenzoic acid** (EVT-329522) | 108078-14-4.
- Google Patents. (n.d.). US7642374B2 - Process for producing 5-iodo-2-methylbenzoic acid.
- Google Patents. (n.d.). CN108129322B - Synthetic method of 2-nitro-3-methylbenzoic acid.
- Quick Company. (n.d.). Process For Producing 5 Iodo 2 Methylbenzoic Acid.
- PrepChem.com. (n.d.). Synthesis of 2-iodo-5-methyl-benzoic acid.
- ChemicalBook. (n.d.). 2-IODO-5-METHYLBENZOIC ACID synthesis.

- Google Patents. (n.d.). JP2003012597A - Method for producing monoiodine of methylbenzoic acid.
- Wikipedia. (n.d.). Sandmeyer reaction.
- Master Organic Chemistry. (2018). Reactions of Diazonium Salts: Sandmeyer and Related Reactions.
- Yakubov, S. H., et al. (2007). m-Iodosylbenzoic acid – a convenient recyclable reagent for highly efficient aromatic iodinations. Beilstein Journal of Organic Chemistry, 3, 19. Retrieved January 31, 2026, from [\[Link\]](#)
- ResearchGate. (2024). Ortho-iodination of aromatic carboxylic acids in aqueous media.
- Organic Chemistry Portal. (n.d.). Sandmeyer Reaction.

Need Custom Synthesis?

BenchChem offers custom synthesis for rare earth carbides and specific isotopic labeling.

Email: info@benchchem.com or [Request Quote Online](#).

Sources

1. Sandmeyer reaction - Wikipedia [en.wikipedia.org]
2. Sandmeyer Reaction [organic-chemistry.org]
3. prepchem.com [prepchem.com]
4. masterorganicchemistry.com [masterorganicchemistry.com]
5. CN108129322B - Synthetic method of 2-nitro-3-methylbenzoic acid - Google Patents [patents.google.com]
6. CN100406422C - Process for producing 5-iodo-2-methylbenzoic acid - Google Patents [patents.google.com]
7. US7642374B2 - Process for producing 5-iodo-2-methylbenzoic acid - Google Patents [patents.google.com]
8. JP2003012597A - Method for producing monoiodine of methylbenzoic acid - Google Patents [patents.google.com]
9. m-Iodosylbenzoic acid – a convenient recyclable reagent for highly efficient aromatic iodinations - PMC [[pmc.ncbi.nlm.nih.gov](https://pubmed.ncbi.nlm.nih.gov)]

- [10. researchgate.net \[researchgate.net\]](https://www.researchgate.net)
- [11. CN112778147A - Preparation method of 2-amino-3-methyl-5-chlorobenzoic acid - Google Patents \[patents.google.com\]](https://patents.google.com/patent/CN112778147A)
- To cite this document: BenchChem. [Technical Support Center: Synthesis of 2-Iodo-3-methylbenzoic Acid]. BenchChem, [2026]. [Online PDF]. Available at: [\[https://www.benchchem.com/product/b027227/docs#technical-support-center-synthesis-of-2-iodo-3-methylbenzoic-acid\]](https://www.benchchem.com/product/b027227/docs#technical-support-center-synthesis-of-2-iodo-3-methylbenzoic-acid)

Disclaimer & Data Validity:

The information provided in this document is for Research Use Only (RUO) and is strictly not intended for diagnostic or therapeutic procedures. While BenchChem strives to provide accurate protocols, we make no warranties, express or implied, regarding the fitness of this product for every specific experimental setup.

Technical Support: The protocols provided are for reference purposes. Unsure if this reagent suits your experiment?

Need Industrial/Bulk Grade? [Request Custom Synthesis Quote](#)

BenchChem

Our mission is to be the trusted global source of essential and advanced chemicals, empowering scientists and researchers to drive progress in science and industry.

Contact

Address: 3281 E Guasti Rd
Ontario, CA 91761, United States
Phone: (601) 213-4426
Email: info@benchchem.com

[Contact our Ph.D. Support Team for a compatibility check](#)

