

Application Note: 1-Ethylazepan-2-one in Polyamide Synthesis

Author: BenchChem Technical Support Team. **Date:** May 2026

Compound of Interest

Compound Name: 1-Ethylazepan-2-one

CAS No.: 19797-08-1

Cat. No.: B027321

[Get Quote](#)

Engineering Crystallinity and Solubility Profiles via - Substituted Lactam Copolymerization

Part 1: Scientific Rationale & Mechanism[1][2]

1.1 Introduction

The synthesis of Polyamide 6 (Nylon 6) via Anionic Ring-Opening Polymerization (AROP) is a mature industrial process. However, the resulting homopolymer often exhibits high crystallinity (

) and a high melting point (

), which can limit its application in flexible coatings, membrane technologies, and optical transparency.

1-Ethylazepan-2-one (also known as

-ethylcaprolactam or NECL) represents a critical "disruptor monomer" in this landscape. Unlike unsubstituted

-caprolactam, NECL possesses an ethyl group on the nitrogen atom. This substitution

eliminates the amide hydrogen responsible for the strong inter-chain hydrogen bonding () characteristic of nylons.

1.2 The "Crystal Disruption" Hypothesis

Incorporating **1-Ethylazepan-2-one** into a polyamide backbone introduces steric bulk and removes hydrogen bond donors.

- Thermodynamic Consequence: The enthalpy of crystallization () decreases significantly as NECL content increases.
- Kinetic Consequence: The polymerization rate of NECL is lower than caprolactam due to the higher stability of the secondary amine anion intermediate and steric hindrance at the reaction site.

Therefore, NECL is rarely used as a homopolymer in AROP. This guide focuses on its application as a functional comonomer to tune the

, and solubility of the final polyamide matrix.

1.3 Reaction Mechanism: The "Crossover" Propagation

In a copolymerization system containing Caprolactam (CLa) and **1-Ethylazepan-2-one** (NECL), the propagation involves two distinct active centers.

- Primary Initiation: The caprolactamate anion attacks the activator (-acetylcaprolactam).
- Crossover Propagation: The growing macro-anion can attack either a CLa monomer or a NECL monomer.
 - Attack on NECL: The ring opens to form a secondary amine anion (). This species is more basic but less nucleophilic due to steric hindrance, slowing the overall rate.

- Re-initiation: The

end-group must attack a CLA monomer to restore the faster kinetics.

Part 2: Experimental Protocol

Objective: Synthesis of a Poly(caprolactam-co-N-ethylcaprolactam) random copolymer (80:20 molar ratio) via Anionic Ring-Opening Polymerization.

2.1 Reagents & Materials

Reagent	Role	Purity / Specs	Handling Note
-Caprolactam (CLA)	Main Monomer	>99.9%, Flaked	Hygroscopic. Dry under vacuum at for 12h.
1-Ethylazepan-2-one (NECL)	Comonomer	>98% (CAS 2407-94-5)	Distill over before use.[1] Store under .
Sodium Caprolactamate	Initiator	1M in Caprolactam	Prepare fresh or use commercial grade (e.g., Brüggolen C10).
-Acetylcaprolactam	Activator	>99%	Liquid. Moisture sensitive.
Toluene	Quenching/Solvent	Anhydrous	For post-reaction washing.

2.2 Experimental Workflow

The following protocol utilizes a melt-mixing approach suitable for laboratory-scale glass reactors.

Step 1: System Preparation

- Equip a 250 mL flanged glass reactor with a high-torque overhead stirrer, nitrogen inlet/outlet, and a thermocouple.
- Flame-dry the reactor under a continuous stream of dry Nitrogen () to remove surface moisture. Critical: Moisture > 100 ppm will terminate the anionic centers.

Step 2: Monomer Melting & Mixing

- Charge 45.2 g (0.4 mol) of dried -Caprolactam and 14.1 g (0.1 mol) of **1-Ethylazepan-2-one** into the reactor.
- Heat the mixture to under slow stirring (50 rpm) until fully molten.
- Purge with for 20 minutes to degas the melt.

Step 3: Initiation (The "Two-Pot" Method) To ensure homogeneity, the catalyst system is split.

- Pot A (Activator): Add 0.85 g (5 mmol) of -Acetylcaprolactam to the molten monomer mix. Stir for 5 mins.
- Pot B (Initiator): Separately, prepare a small masterbatch of Sodium Caprolactamate in Caprolactam (or add 0.7 g of solid Na-Caprolactamate directly if handling allows inert transfer).
- Injection: Quickly inject the Initiator (Pot B) into the Reactor (Pot A).
- Increase stirring speed to 200 rpm immediately.

Step 4: Polymerization

- Raise temperature to

- . Note: We use a lower temperature than standard Nylon 6 () to favor the equilibrium conversion of the N-ethyl monomer.
- The viscosity will increase rapidly within 5-10 minutes (Weissenberg effect).
 - Maintain temperature for 60 minutes.
 - Annealing (Optional): For higher conversion, hold at for an additional 2 hours.

Step 5: Quenching & Isolation

- Stop heating and allow the polymer block to cool to room temperature.
- Crush the solid polymer block.
- Extraction: Reflux the crude polymer in Methanol or hot water for 6 hours to remove unreacted monomer (equilibrium monomer content is higher in copolymers).
- Dry in a vacuum oven at for 24 hours.

2.3 Characterization & Validation

Technique	Parameter	Expected Trend (vs. Pure PA6)
DSC	Melting Point ()	Depression ()
DSC	Crystallinity ()	Significant reduction ()
NMR ()	Composition	Peak at 3.4 ppm (N-CH ₂ -CH ₃) confirms incorporation.
Solubility	Solvent Resistance	Soluble in alcohol/CHCl ₃ mixtures (Pure PA6 is insoluble).

Part 3: Visualization

3.1 Mechanism of Copolymerization

This diagram illustrates the anionic attack sequence, highlighting the steric challenge introduced by the Ethyl group.

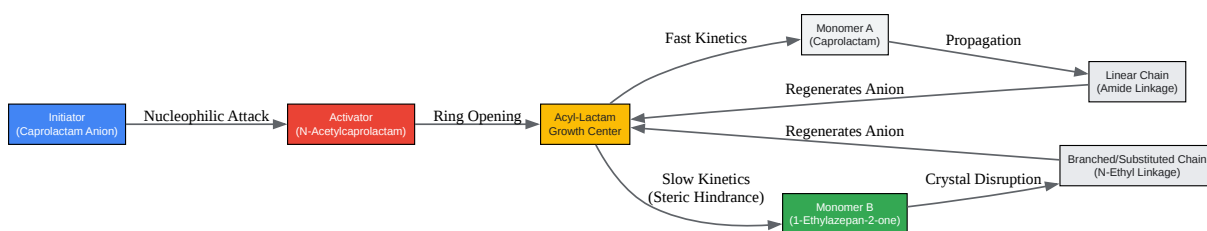

[Click to download full resolution via product page](#)

Figure 1: Reaction pathway for the anionic copolymerization of Caprolactam and **1-Ethylazepan-2-one**.

3.2 Experimental Setup Diagram

A visual guide to the reactor configuration required to maintain anhydrous conditions.

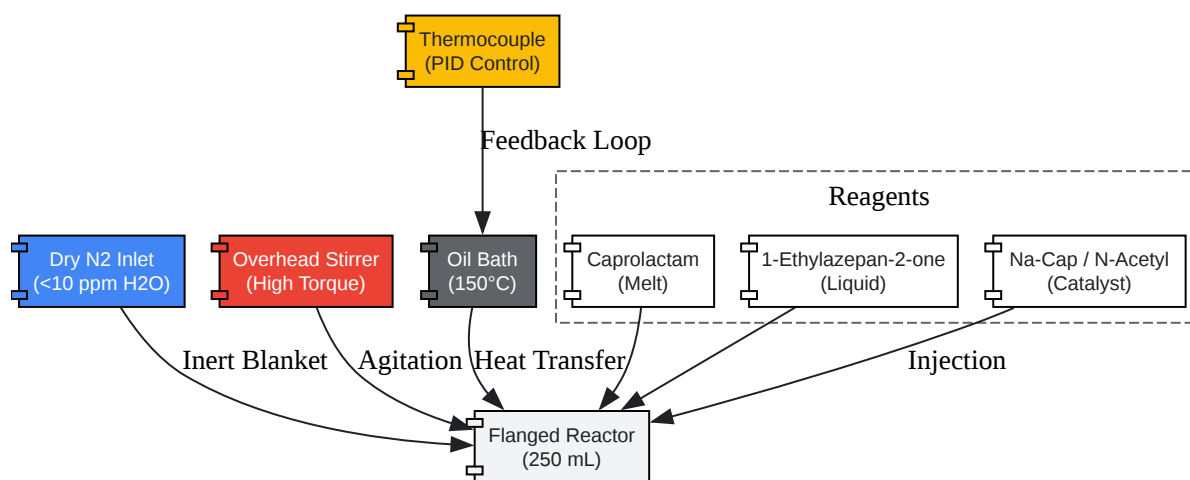

[Click to download full resolution via product page](#)

Figure 2: Reactor configuration for moisture-sensitive anionic polymerization.

Part 4: References

- Russo, A. et al. (2013).[2] Polymers and Related Composites via Anionic Ring-Opening Polymerization of Lactams: Recent Developments. MDPI Polymers. [\[Link\]](#)[1]
- Udipi, K. et al. (1997). Anionic Ring-Opening Polymerization of Lactams. Polymer Engineering & Science. [\[Link\]](#)
- National Center for Biotechnology Information. (2024). PubChem Compound Summary for CID 104693193, **1-Ethylazepan-2-one** derivatives. [\[Link\]](#)
- Cimecioglu, A. L. (2019). Copolymers of ϵ -caprolactone and ϵ -caprolactam via polyesterification. Royal Society of Chemistry, Polymer Chemistry. [\[Link\]](#)

- Hashimoto, K. (2010). Ring-Opening Polymerization of Lactams.[3][4] Living Anionic Polymerization. Progress in Polymer Science. [\[Link\]](#)

Need Custom Synthesis?

BenchChem offers custom synthesis for rare earth carbides and specific isotopic labeling.

Email: info@benchchem.com or [Request Quote Online](#).

Sources

- 1. 2(5H)-Furanone, 5-ethyl- (CAS 2407-43-4) - Chemical & Physical Properties by Cheméo [\[chemeo.com\]](https://chemeo.com)
- 2. Anionic ring-opening polymerization of ethylene oxide in DMF with cyclodextrin derivatives as new initiators - PubMed [\[pubmed.ncbi.nlm.nih.gov\]](https://pubmed.ncbi.nlm.nih.gov)
- 3. pubs.rsc.org [\[pubs.rsc.org\]](https://pubs.rsc.org)
- 4. mdpi.com [\[mdpi.com\]](https://mdpi.com)
- To cite this document: BenchChem. [Application Note: 1-Ethylazepan-2-one in Polyamide Synthesis]. BenchChem, [2026]. [Online PDF]. Available at: [\[https://www.benchchem.com/product/b027321/docs#application-note-1-ethylazepan-2-one-in-polyamide-synthesis\]](https://www.benchchem.com/product/b027321/docs#application-note-1-ethylazepan-2-one-in-polyamide-synthesis)

Disclaimer & Data Validity:

The information provided in this document is for Research Use Only (RUO) and is strictly not intended for diagnostic or therapeutic procedures. While BenchChem strives to provide accurate protocols, we make no warranties, express or implied, regarding the fitness of this product for every specific experimental setup.

Technical Support: The protocols provided are for reference purposes. Unsure if this reagent suits your experiment?

Need Industrial/Bulk Grade? [Request Custom Synthesis Quote](#)

BenchChem

Our mission is to be the trusted global source of essential and advanced chemicals, empowering scientists and researchers to drive progress in science and industry.

Contact

Address: 3281 E Guasti Rd

Ontario, CA 91761, United States

Phone: (601) 213-4426

Email: info@benchchem.com

[Contact our Ph.D. Support Team for a compatibility check](#)