

An In-depth Technical Guide to FK962: Chemical Structure and Properties

Author: BenchChem Technical Support Team. **Date:** April 2026

Compound of Interest

Compound Name:	FK962
CAS No.:	283167-06-6
Cat. No.:	B2693539

[Get Quote](#)

For Researchers, Scientists, and Drug Development Professionals

Abstract

FK962, with the IUPAC name N-(1-acetylpiperidin-4-yl)-4-fluorobenzamide, is a synthetic small molecule that has garnered significant interest for its potential therapeutic applications, particularly in the realm of neurodegenerative disorders and cognitive enhancement. This technical guide provides a comprehensive overview of the chemical structure, physicochemical properties, and the intricate signaling pathways modulated by **FK962**. It is intended to serve as a detailed resource for researchers and professionals involved in drug discovery and development, offering insights into its mechanism of action and methodologies for its study. All quantitative data are presented in structured tables, and key experimental protocols are detailed. Furthermore, signaling pathways and experimental workflows are visualized using Graphviz diagrams to facilitate a deeper understanding of the molecular interactions and experimental designs.

Chemical Structure and Physicochemical Properties

FK962 is a benzamide derivative characterized by a fluorinated phenyl ring linked to an acetylated piperidine moiety. Its chemical structure is fundamental to its biological activity, enabling it to interact with specific molecular targets.

Chemical Identifiers and Molecular Details

Property	Value	Reference
IUPAC Name	N-(1-acetylpiperidin-4-yl)-4-fluorobenzamide	
Chemical Formula	C ₁₄ H ₁₇ FN ₂ O ₂	[1]
Molecular Weight	264.30 g/mol	[1]
CAS Number	283167-06-6	
SMILES	CC(=O)N1CCC(CC1)NC(=O)C2=CC=C(C=C2)F	

Physicochemical Properties

Property	Value	Reference
Melting Point	Not available in the searched literature.	
Solubility	Not available in the searched literature.	
logP	Not available in the searched literature.	

Synthesis of FK962

While a detailed, step-by-step synthesis protocol for **FK962** is not readily available in the public domain, the synthesis of structurally similar N-substituted benzamides typically involves the coupling of a carboxylic acid derivative with an amine. A plausible synthetic route for **FK962** would involve the acylation of 4-amino-1-acetylpiperidine with 4-fluorobenzoyl chloride.

General Experimental Protocol for the Synthesis of N-substituted Benzamides

The following is a generalized protocol for the synthesis of benzamide derivatives, which can be adapted for the synthesis of **FK962**.

Materials:

- 4-fluorobenzoic acid
- Thionyl chloride or oxalyl chloride
- 4-amino-1-acetylpiperidine
- Anhydrous dichloromethane (DCM)
- Triethylamine (TEA) or other suitable base
- Anhydrous sodium sulfate or magnesium sulfate
- Silica gel for column chromatography
- Solvents for chromatography (e.g., hexane, ethyl acetate)

Procedure:

- **Activation of 4-fluorobenzoic acid:** 4-fluorobenzoic acid is converted to its more reactive acid chloride derivative. This is typically achieved by reacting it with thionyl chloride or oxalyl chloride in an anhydrous solvent like DCM, often with a catalytic amount of dimethylformamide (DMF). The reaction is usually carried out at room temperature or with gentle heating.
- **Amide Coupling:** The resulting 4-fluorobenzoyl chloride is then reacted with 4-amino-1-acetylpiperidine in an anhydrous solvent such as DCM in the presence of a base like triethylamine to neutralize the HCl byproduct. The reaction is typically stirred at room temperature until completion, which can be monitored by thin-layer chromatography (TLC).

- **Work-up and Purification:** Upon completion, the reaction mixture is washed with water and brine to remove any water-soluble impurities. The organic layer is then dried over anhydrous sodium sulfate or magnesium sulfate, filtered, and the solvent is removed under reduced pressure. The crude product is then purified, typically by flash column chromatography on silica gel using an appropriate solvent system (e.g., a gradient of ethyl acetate in hexane).
- **Characterization:** The final product, **FK962**, is characterized by standard analytical techniques such as ^1H NMR, ^{13}C NMR, and mass spectrometry to confirm its structure and purity.

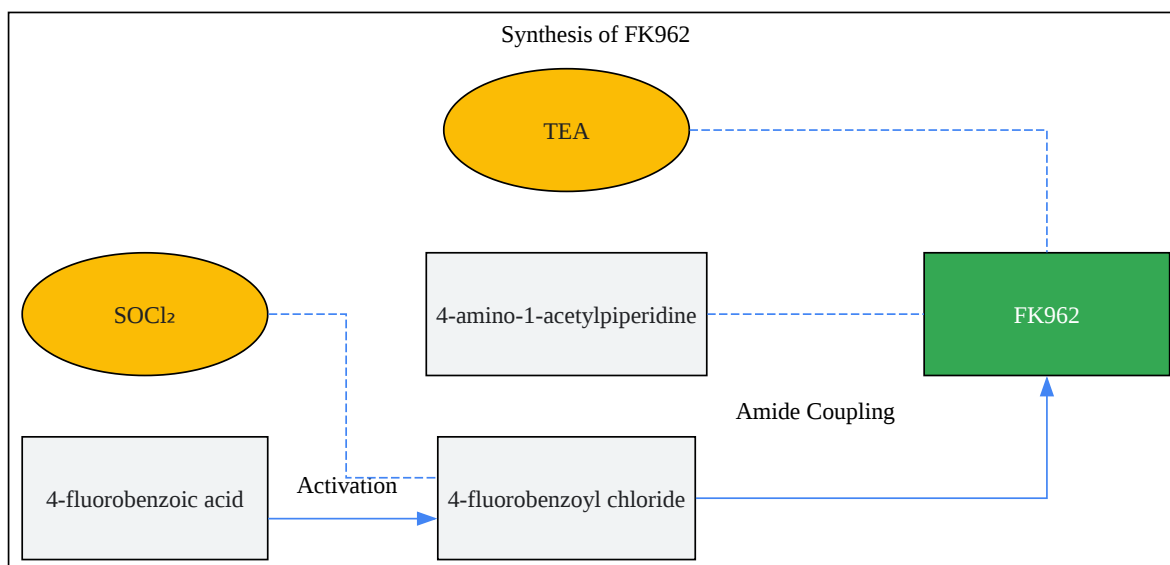

[Click to download full resolution via product page](#)

Caption: Plausible synthetic workflow for **FK962**.

Biological Activity and Mechanism of Action

FK962 is primarily recognized as an enhancer of somatostatin release and has demonstrated neuroprotective and cognitive-enhancing properties in various preclinical models.[2] Its mechanism of action appears to be multifaceted, involving at least two distinct signaling pathways.

Somatostatin Release Enhancement

FK962 has been shown to potentiate the release of somatostatin, a neuropeptide that plays a crucial role in neurotransmission and cognitive processes.[2] Somatostatin exerts its effects by binding to a family of G-protein coupled receptors (GPCRs), namely SSTR1-5. The activation of these receptors typically leads to the inhibition of adenylyl cyclase, resulting in decreased intracellular cyclic AMP (cAMP) levels. This signaling cascade is implicated in the modulation of neuronal excitability and hormone secretion.

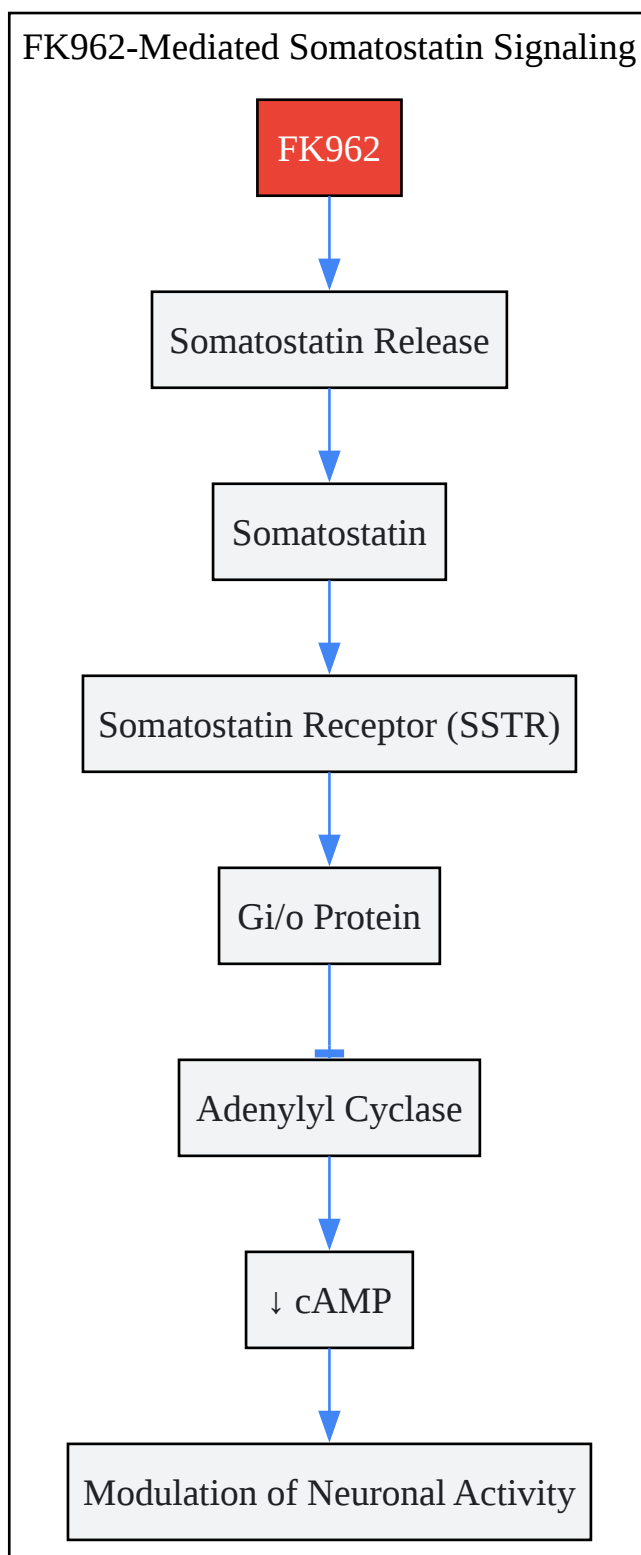

[Click to download full resolution via product page](#)

Caption: **FK962** enhances somatostatin release and signaling.

Neuroprotection via GDNF Signaling

In addition to its effects on the somatostatinergic system, **FK962** has been found to exert neuroprotective effects through the induction of Glial Cell Line-Derived Neurotrophic Factor (GDNF).[1] GDNF is a potent neurotrophic factor that promotes the survival and differentiation of various neuronal populations. The neuroprotective effects of **FK962** are mediated by the activation of the GDNF receptor, a receptor tyrosine kinase known as RET. This activation triggers two key downstream survival pathways: the PI3K/AKT and the MEK/ERK pathways. The simultaneous activation of both the AKT and ERK pathways is crucial for the neuroprotective effects of **FK962**.[\[1\]](#)

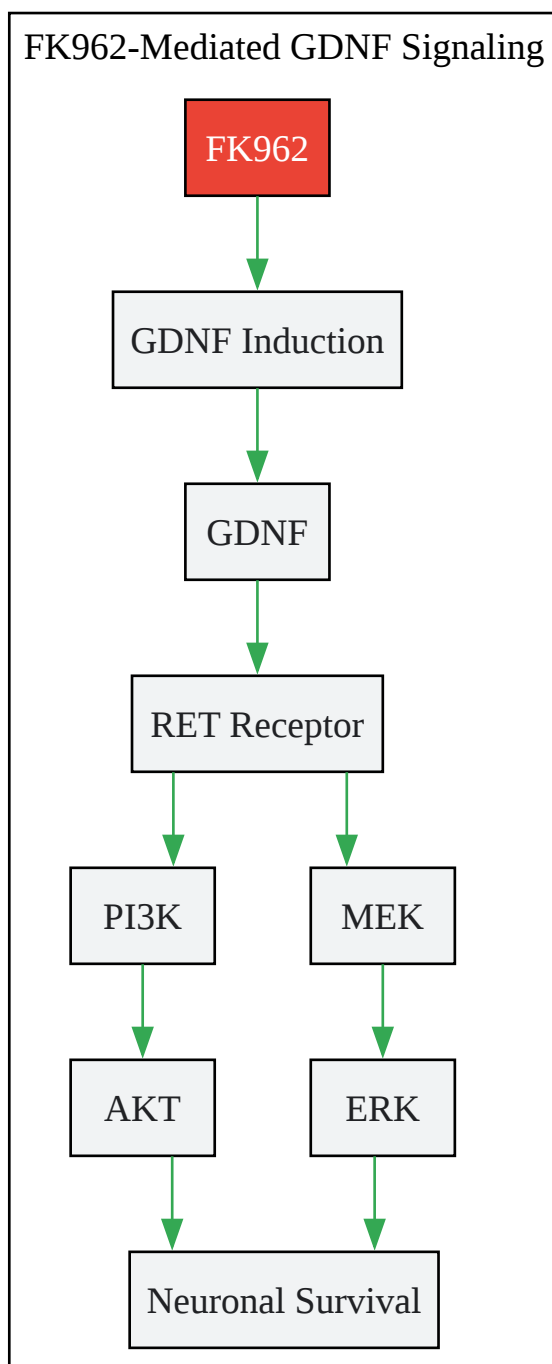

[Click to download full resolution via product page](#)

Caption: **FK962** promotes neuronal survival via GDNF signaling.

Experimental Protocols for Investigating Biological Activity

In Vitro Somatostatin Release Assay

This protocol is designed to measure the effect of **FK962** on somatostatin release from primary neuronal cultures or brain slices.

Materials:

- Primary hippocampal or cortical neuron cultures, or acute brain slices
- Artificial cerebrospinal fluid (aCSF)
- High potassium (K⁺) aCSF (for depolarization-induced release)
- **FK962** stock solution
- Somatostatin ELISA kit
- 96-well plates
- Plate reader

Procedure:

- Preparation of Cultures/Slices: Prepare primary neuronal cultures or acute brain slices according to standard laboratory protocols.
- Pre-incubation: Equilibrate the cultures/slices in aCSF for a defined period.
- Treatment: Replace the medium with aCSF containing various concentrations of **FK962** or vehicle control.
- Stimulation: To measure depolarization-induced release, replace the treatment medium with high K⁺ aCSF (containing **FK962** or vehicle) for a short period (e.g., 15 minutes).
- Sample Collection: Collect the supernatant (aCSF) from each well.
- Quantification: Measure the concentration of somatostatin in the collected supernatants using a commercially available somatostatin ELISA kit, following the manufacturer's instructions.

- Data Analysis: Normalize the somatostatin release to the total protein content of the cells/slices in each well. Compare the release in **FK962**-treated groups to the vehicle control group.

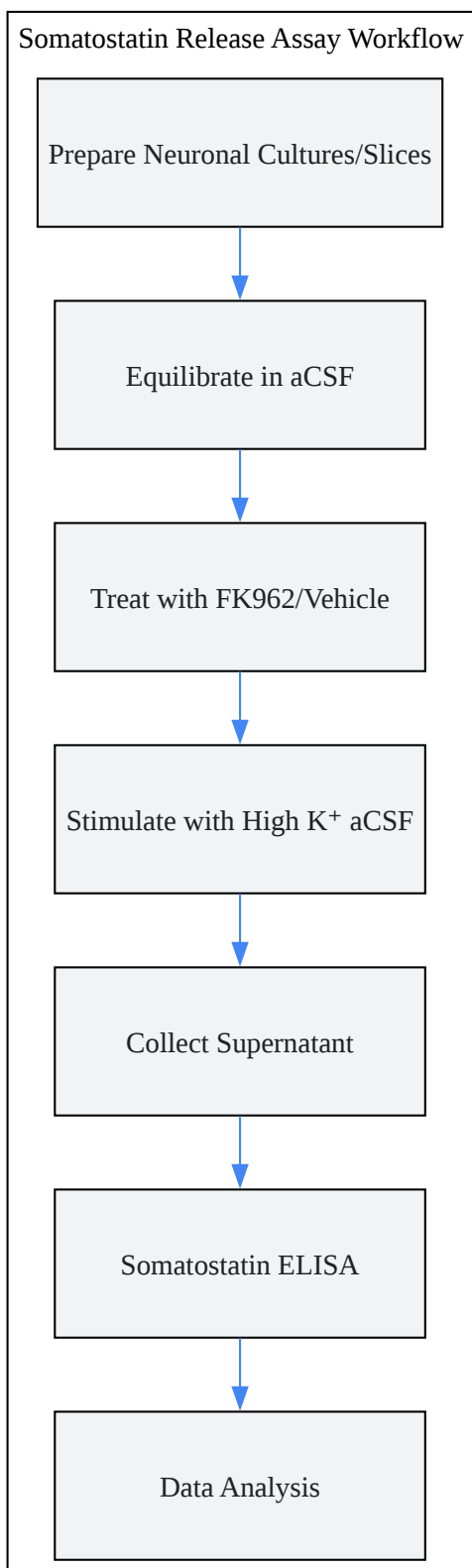

[Click to download full resolution via product page](#)

Need Custom Synthesis?

BenchChem offers custom synthesis for rare earth carbides and specific isotopic labeling.

Email: info@benchchem.com or [Request Quote Online](#).

References

- [1. iovs.arvojournals.org \[iovs.arvojournals.org\]](https://iovs.arvojournals.org)
- [2. FK962, a novel enhancer of somatostatin release, exerts cognitive-enhancing actions in rats - PubMed \[pubmed.ncbi.nlm.nih.gov\]](#)
- To cite this document: BenchChem. [An In-depth Technical Guide to FK962: Chemical Structure and Properties]. BenchChem, [2026]. [Online PDF]. Available at: [\[https://www.benchchem.com/product/b2693539/docs#an-in-depth-technical-guide-to-fk962-chemical-structure-and-properties\]](https://www.benchchem.com/product/b2693539/docs#an-in-depth-technical-guide-to-fk962-chemical-structure-and-properties)

Disclaimer & Data Validity:

The information provided in this document is for Research Use Only (RUO) and is strictly not intended for diagnostic or therapeutic procedures. While BenchChem strives to provide accurate protocols, we make no warranties, express or implied, regarding the fitness of this product for every specific experimental setup.

Technical Support: The protocols provided are for reference purposes. Unsure if this reagent suits your experiment?

Need Industrial/Bulk Grade? [Request Custom Synthesis Quote](#)

BenchChem

Our mission is to be the trusted global source of essential and advanced chemicals, empowering scientists and researchers to drive progress in science and industry.

Contact

Address: 3281 E Guasti Rd

Ontario, CA 91761, United States

Phone: (601) 213-4426

Email: info@benchchem.com

Contact our Ph.D. Support Team for a compatibility check