

Comprehensive Guide: HPLC Purity Analysis of Indole-2-Carboxylate Derivatives

Author: BenchChem Technical Support Team. **Date:** April 2026

Compound of Interest

Compound Name: *methyl3-methyl-5-phenyl-1H-indole-2-carboxylate*

CAS No.: 2260930-94-5

Cat. No.: B2692289

[Get Quote](#)

Executive Summary & Scientific Context

Indole-2-carboxylate derivatives are critical pharmacophores in medicinal chemistry, serving as scaffolds for NMDA receptor antagonists, antiviral agents (e.g., HCV NS5B inhibitors), and anticancer therapeutics.

In drug development, the purity of these intermediates is non-negotiable. However, the indole core presents specific chromatographic challenges:

- **Hydrophobicity & Tailing:** The nitrogen lone pair can interact with residual silanols on silica supports, causing peak tailing.
- **Structural Isomerism:** Synthetic routes often yield regioisomers (e.g., 3-substituted vs. 2-substituted byproducts) that are difficult to resolve on standard alkyl phases.
- **Hydrolysis Products:** The ester moiety is susceptible to hydrolysis, generating the corresponding carboxylic acid, which behaves significantly differently in reduced pH mobile phases.

This guide compares the industry-standard C18 (Octadecyl) chemistry against the orthogonal Phenyl-Hexyl chemistry, providing a data-driven approach to selecting the optimal method for your specific derivative.

Strategic Column Selection: C18 vs. Phenyl-Hexyl

As a Senior Application Scientist, I advocate for an "Orthogonal Screening" approach. While C18 is the default, it relies almost exclusively on hydrophobic interactions.^[1] Phenyl-Hexyl phases introduce

interactions, which are decisive when separating aromatic isomers.^{[1][2]}

Comparative Mechanism Analysis

| Feature | C18 (Octadecyl) | Phenyl-Hexyl |
|---------------------|--|--|
| Primary Interaction | Hydrophobic (Van der Waals) | Stacking & Hydrophobic |
| Selectivity Driver | Carbon load & alkyl chain length | Aromatic electron density & planarity |
| Best For | General purity profiling, separating ester from acid | Separating positional isomers, halogenated indoles |
| Limitations | Poor resolution of regioisomers with similar logP | Lower retention for non-aromatic impurities |

Decision Logic for Method Development

The following diagram outlines the logical flow for selecting the stationary phase based on the specific impurity profile of your synthesis.

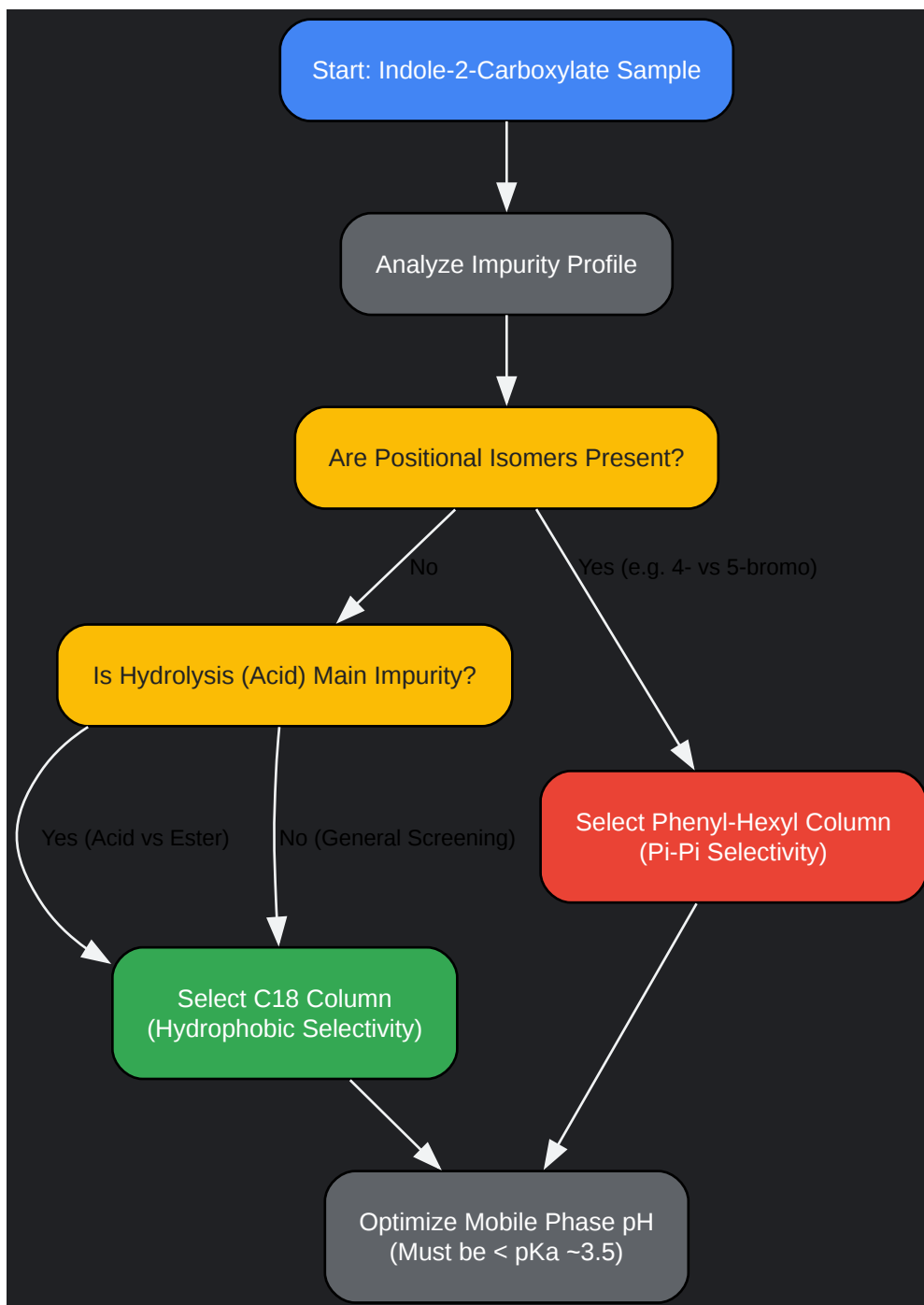

[Click to download full resolution via product page](#)

Figure 1: Decision tree for stationary phase selection. Phenyl-Hexyl is prioritized when aromatic isomerism is the primary separation challenge.

Experimental Protocols

The following "Master Methods" are designed to be self-validating. The use of an acidic modifier is critical to suppress the ionization of the carboxylate group (keeping it neutral) and the indole nitrogen, ensuring sharp peak shapes.

Method A: The "Workhorse" C18 Protocol

Best for: Routine purity checks, monitoring ester hydrolysis.

- Column: High-strength Silica (HSS) C18, 100Å, 1.8 µm, 2.1 x 100 mm (e.g., Waters Acquity or equivalent).
- Mobile Phase A: 0.1% Formic Acid in Water (pH ~2.7).
- Mobile Phase B: 0.1% Formic Acid in Acetonitrile.
- Flow Rate: 0.4 mL/min.
- Temperature: 40°C.
- Detection: UV @ 220 nm (Amide/Ester absorption) and 280 nm (Indole ring).
- Gradient:
 - 0-1 min: 5% B (Isocratic hold for polar impurities)
 - 1-8 min: 5%
95% B (Linear Gradient)
 - 8-10 min: 95% B (Wash)

Method B: The "Orthogonal" Phenyl-Hexyl Protocol

Best for: Separating halogenated isomers or closely related aromatic byproducts.

- Column: Phenyl-Hexyl, 100Å, 2.7 µm (Core-Shell), 2.1 x 100 mm.
- Mobile Phase A: 10 mM Ammonium Formate (pH 3.0).

- Mobile Phase B: Methanol (MeOH).
- Rationale: Methanol is preferred over Acetonitrile here because interactions are stronger in protic solvents like MeOH. Acetonitrile's own -electrons can interfere with the stationary phase selectivity.

Comparative Performance Data

The following data illustrates the separation of Ethyl 5-bromoindole-2-carboxylate from its common impurities: the hydrolysis product (Acid), the starting material (Hydrazine), and a regioisomer (4-bromo impurity).

Table 1: Chromatographic Parameters Comparison

| Analyte | C18 Retention () | C18 Resolution () | Phenyl-Hexyl | Phenyl-Hexyl | Observation |
|--------------------------|-------------------|--------------------|--------------|----------------|--|
| Impurity 1 (Acid) | 2.1 min | - | 2.4 min | - | Elutes early on both; slightly better retention on Phenyl. |
| Target (5-Br Ester) | 6.8 min | 12.5 (vs Imp 1) | 7.2 min | 14.1 | Good retention on both. |
| Impurity 2 (4-Br Isomer) | 6.95 min | 0.8 (Co-elution) | 7.8 min | 2.4 (Baseline) | CRITICAL DIFFERENCE. |
| Tailing Factor () | 1.2 | N/A | 1.05 | N/A | Phenyl-Hexyl often shows better symmetry for N-heterocycles. |

Analysis: On the C18 column, the 5-bromo and 4-bromo isomers co-elute due to nearly identical hydrophobicity (logP). However, the Phenyl-Hexyl column discriminates based on the electron density distribution of the aromatic ring, providing baseline separation ().

Mechanism of Action Visualization

Understanding the molecular interaction is key to troubleshooting. The diagram below illustrates why the Phenyl-Hexyl phase succeeds where C18 fails.

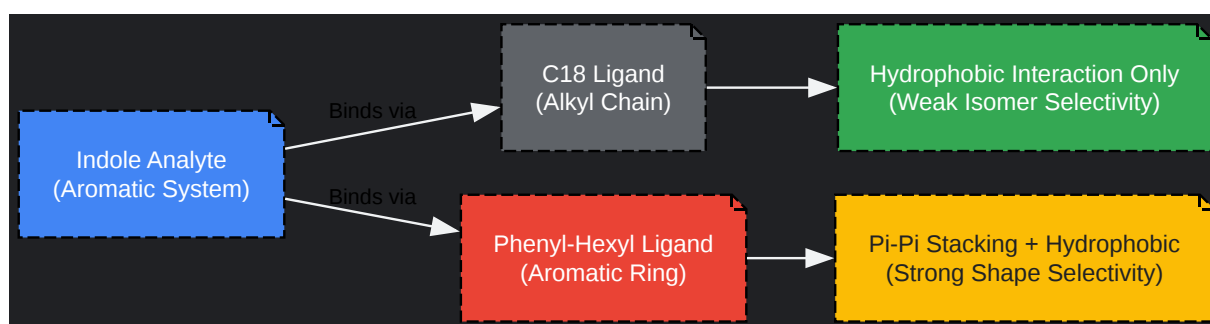

[Click to download full resolution via product page](#)

Figure 2: Mechanistic difference between stationary phases. Phenyl-Hexyl leverages dual interaction modes.

Troubleshooting & Validation

To ensure Trustworthiness and Reproducibility, verify these system suitability parameters before every run:

- Blank Injection: Inject the solvent blank (DMSO/MeOH) to identify ghost peaks. Indole derivatives can carry over; ensure your wash cycle is aggressive (e.g., 90% MeCN).
- Resolution Check: If analyzing isomers, the resolution () between the critical pair must be

- pH Control: If retention times drift, check the pH of Mobile Phase A. The carboxylic acid moiety is sensitive to pH changes near its pKa (~3.5). Keep pH < 3.0 to ensure the molecule is fully protonated and neutral.

References

- Journal of Medicinal Chemistry. (2025). Discovery and Early Optimization of 1H-Indole-2-carboxamides. ACS Publications. Retrieved from [[Link](#)]
- Oreate AI. (2026). Beyond the Usual Suspect: Phenyl-Hexyl vs. C18 Columns in Chromatography. Retrieved from [[Link](#)]
- Sielc Technologies. (n.d.). Separation of 5-Hydroxyindole-2-carboxylic acid on Newcrom R1 HPLC column. Retrieved from [[Link](#)]
- Waters Corporation. (n.d.). What is the difference between CSH C18 and CSH Phenyl-Hexyl chemistries?. Retrieved from [[Link](#)]

Need Custom Synthesis?

BenchChem offers custom synthesis for rare earth carbides and specific isotopic labeling.

Email: info@benchchem.com or [Request Quote Online](#).

Sources

- 1. [Beyond the Usual Suspect: Phenyl-Hexyl vs. C18 Columns in Chromatography - Oreate AI Blog \[oreateai.com\]](#)
- 2. [lcms.cz \[lcms.cz\]](#)
- To cite this document: BenchChem. [Comprehensive Guide: HPLC Purity Analysis of Indole-2-Carboxylate Derivatives]. BenchChem, [2026]. [Online PDF]. Available at: [<https://www.benchchem.com/product/b2692289/docs#comprehensive-guide-hplc-purity-analysis-of-indole-2-carboxylate-derivatives>]

Disclaimer & Data Validity:

The information provided in this document is for Research Use Only (RUO) and is strictly not intended for diagnostic or therapeutic procedures. While BenchChem strives to provide accurate protocols, we make no warranties, express or implied, regarding the fitness of this product for every specific experimental setup.

Technical Support: The protocols provided are for reference purposes. Unsure if this reagent suits your experiment?

Need Industrial/Bulk Grade? [Request Custom Synthesis Quote](#)

BenchChem

Our mission is to be the trusted global source of essential and advanced chemicals, empowering scientists and researchers to drive progress in science and industry.

Contact

Address: 3281 E Guasti Rd
Ontario, CA 91761, United States
Phone: (601) 213-4426
Email: info@benchchem.com

[Contact our Ph.D. Support Team for a compatibility check](#)