

# Application Note: High-Sensitivity LC-MS/MS Identification of Synthetic Cathinones in Biofluids

**Author:** BenchChem Technical Support Team. **Date:** April 2026

## Compound of Interest

Compound Name:	2-(Ethylamino)-N-methylpropanamide hydrochloride
CAS No.:	2137457-79-3
Cat. No.:	B2691018

[Get Quote](#)

## Introduction & Mechanistic Rationale

Synthetic cathinones (e.g., mephedrone, MDPV,  $\alpha$ -PVP, and 3-MMC), often marketed as "bath salts," are a rapidly evolving class of new psychoactive substances (NPS). Derived from the naturally occurring alkaloid cathinone found in the khat plant, these  $\beta$ -keto phenethylamines act as potent central nervous system stimulants.

For clinical and forensic toxicologists, the definitive identification of these compounds in biofluids (blood and urine) presents three distinct analytical challenges:

- **Low Physiological Concentrations:** Rapid metabolism and high potency mean that parent drug concentrations in blood are often in the low ng/mL range.
- **Positional Isomerism:** The illicit market frequently shifts between structural isomers (e.g., 3-MMC vs. 4-MMC) to evade legal frameworks. These isomers share identical molecular

weights and fragmentation patterns, rendering mass spectrometry alone insufficient for differentiation.

- Matrix Effects: Endogenous phospholipids in blood and high salt concentrations in urine can cause severe ion suppression during electrospray ionization (ESI).

To overcome these hurdles, Liquid Chromatography coupled with Tandem Mass Spectrometry (LC-MS/MS) has become the gold standard. This application note details a robust, self-validating LC-MS/MS methodology designed to achieve unambiguous identification and quantification of synthetic cathinones in complex biological matrices [1](#)[1].

## Experimental Design & Causality

Do not merely execute steps; understand the physicochemical rationale driving the protocol. Every phase of this workflow is engineered to exploit the specific chemical properties of cathinones.

## The Logic of Isomeric Separation

A critical failure point in standard LC-MS/MS protocols is the inability to resolve positional isomers. For example, 3-methylmethcathinone (3-MMC) and 4-methylmethcathinone (4-MMC) both exhibit a precursor ion of  $m/z$  178.1 and a primary product ion of  $m/z$  160.1. Standard C18 columns often co-elute these compounds.

The Solution: We utilize a Core-Shell Biphenyl stationary phase. Unlike C18, which relies purely on hydrophobic dispersion forces, biphenyl phases offer  $\pi$ - $\pi$  interactions. The subtle steric differences between the meta (3-) and para (4-) methyl placements on the aromatic ring interact differently with the biphenyl rings of the stationary phase, achieving baseline chromatographic resolution<sup>2</sup>[2].

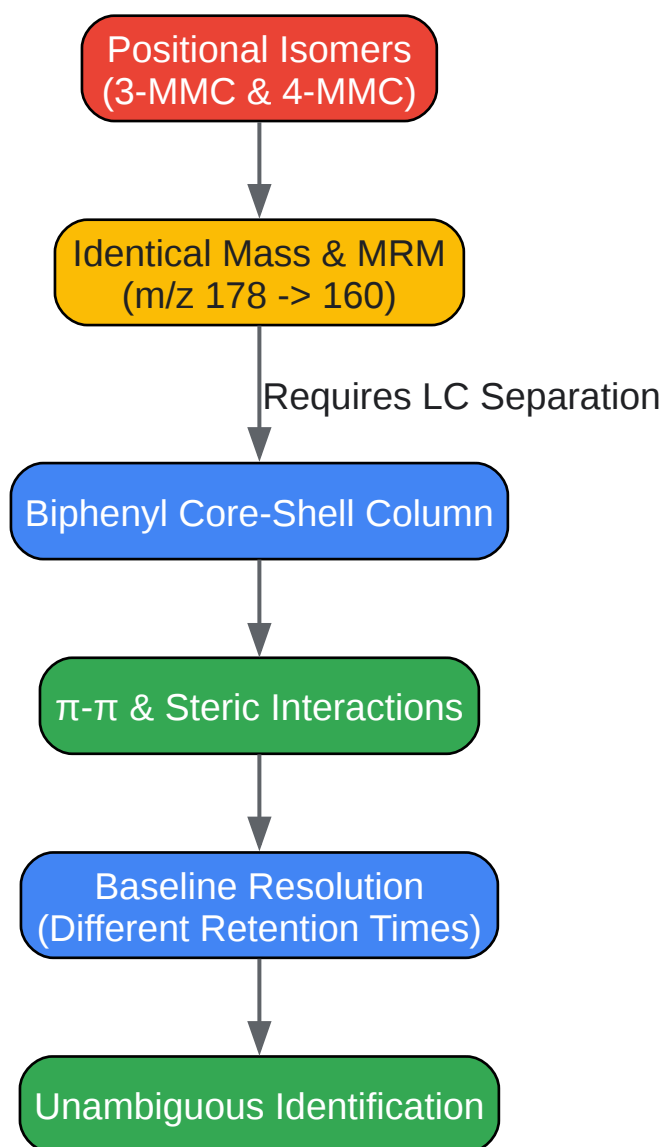

[Click to download full resolution via product page](#)

Fig 1. Mechanistic logic for separating positional cathinone isomers via LC-MS/MS.

## A Self-Validating Quality Control System

To ensure absolute trustworthiness, this protocol is designed as a self-validating system. Matched isotopically labeled internal standards (e.g., Mephedrone-d3,  $\alpha$ -PVP-d8) are spiked into the raw biofluid before any sample manipulation. Because the deuterated analogs share identical extraction recoveries and co-elute with the target analytes, they experience the exact same matrix-induced ion suppression/enhancement in the ESI source. By quantifying based on the Analyte/IS peak area ratio, the method mathematically normalizes physical losses and

matrix effects. Furthermore, the system mandates the monitoring of two MRM transitions (Quantifier and Qualifier); the ion ratio must fall within  $\pm 20\%$  of the reference standard to confirm peak purity.

## Step-by-Step Methodologies

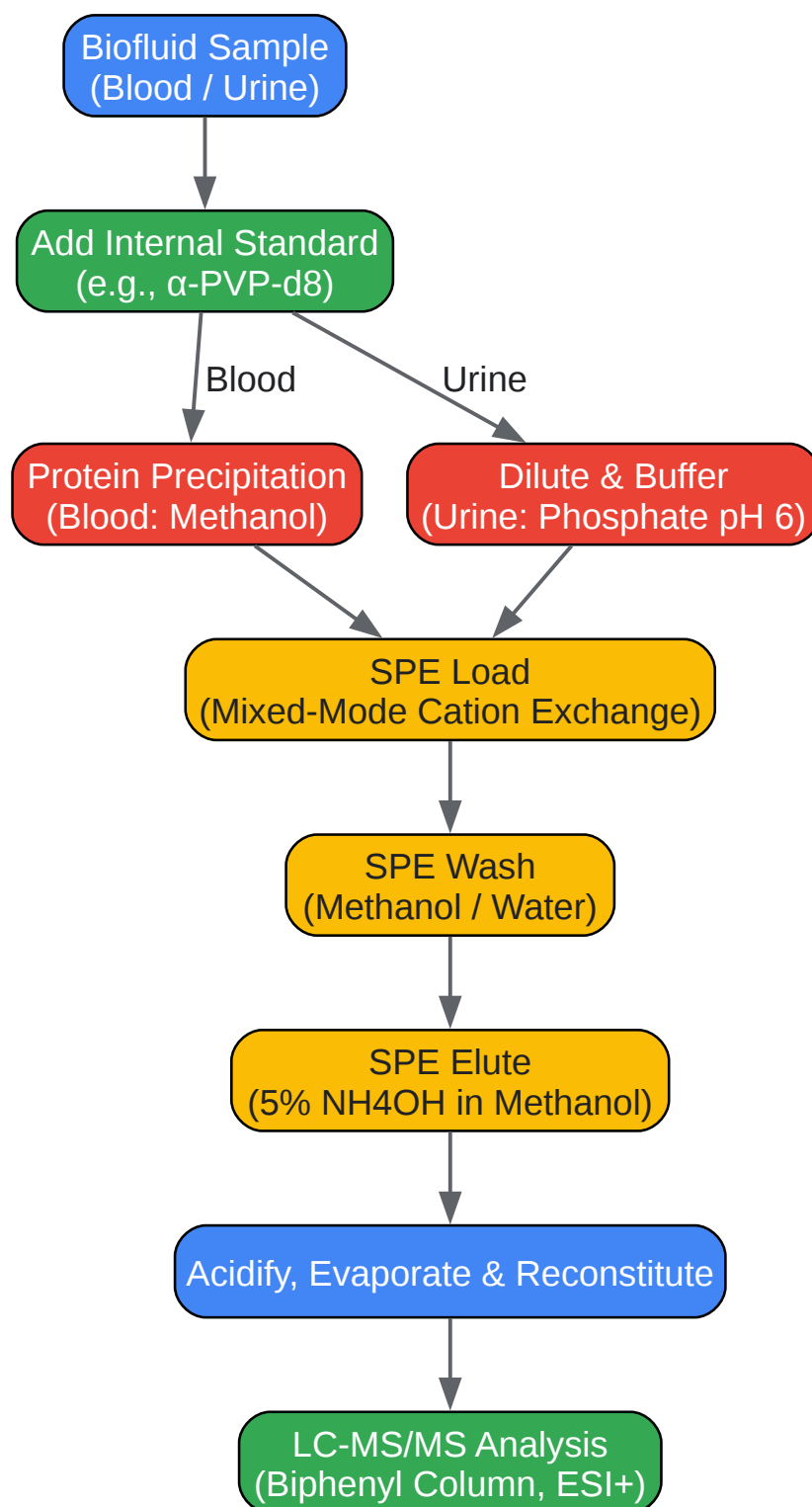

[Click to download full resolution via product page](#)

Fig 2. Sample preparation workflow for synthetic cathinones in blood and urine.

## Biofluid Stability & Storage

Causality Check: Synthetic cathinones, particularly their enantiomers, are highly susceptible to degradation in alkaline conditions and at room temperature<sup>3</sup>[3]. Whole blood samples must be stored at  $-20^{\circ}\text{C}$  in tubes containing sodium fluoride/potassium oxalate to inhibit enzymatic degradation.

## Extraction Protocol A: Mixed-Mode Cation Exchange (MCX) SPE

This protocol provides the highest cleanliness for both blood and urine, achieving Limits of Detection (LOD) in the sub-ng/mL range<sup>4</sup>[4].

Mechanism: Cathinones are basic amines (  $\text{pK}_a \approx 7.5\text{--}9.0$  ). By buffering the sample to pH 6, the analytes become fully protonated (cationic) and bind strongly to the sulfonic acid groups of the MCX sorbent via ionic interactions.

- Sample Aliquot & IS Addition: Aliquot 200 $\mu\text{L}$  of urine or whole blood into a microcentrifuge tube. Add 20 $\mu\text{L}$  of the deuterated Internal Standard mix ( 100ng/mL ).
- Pre-treatment:
  - For Blood: Add 600 $\mu\text{L}$  of ice-cold Methanol to precipitate proteins. Vortex for 1 min, centrifuge at 10,000 $\times g$  for 5 mins. Transfer the supernatant and dilute with 2mL of 0.1M Phosphate Buffer (pH 6.0).
  - For Urine: Dilute directly with 2mL of 0.1M Phosphate Buffer (pH 6.0).
- SPE Conditioning: Condition Oasis MCX cartridges ( 30mg,1cc ) with 1mL Methanol, followed by 1mL Phosphate Buffer (pH 6.0).
- Loading: Load the buffered sample onto the cartridge at a flow rate of 1mL/min .
- Washing (Matrix Removal): Wash with 1mL deionized water, followed by 1mL 100% Methanol. (Causality: Methanol removes neutral and acidic lipids that bind only via weak reversed-phase interactions, leaving the ionically bound cathinones intact).

- Elution: Elute analytes with 1mL of 5% Ammonium Hydroxide (  $\text{NH}_4\text{OH}$  ) in Methanol. (Causality: The high pH deprotonates the cathinones, breaking the ionic bond).
- Acidification & Evaporation (Critical Step): Add 50 $\mu\text{L}$  of 1% HCl in Methanol to the eluate. (Causality: Free-base cathinones are highly volatile. HCl converts them back to stable hydrochloride salts). Evaporate to dryness under a gentle stream of  $\text{N}_2$  at 40°C .
- Reconstitution: Reconstitute in 100 $\mu\text{L}$  of initial mobile phase (95:5 Water:Methanol with 0.1% Formic Acid).

## Extraction Protocol B: "Dilute-and-Shoot" for Urine

For high-throughput pain management or workplace testing where extreme sensitivity is less critical, urine can bypass SPE [5\[5\]](#).

- Centrifuge urine sample at 10,000 $\times g$  for 5 mins to remove particulates.
- Dilute 50 $\mu\text{L}$  of urine with 450 $\mu\text{L}$  of initial mobile phase containing the IS mixture.
- Vortex and inject directly into the LC-MS/MS.

## LC-MS/MS Analytical Conditions

- Column: Restek Raptor Biphenyl ( 100mm $\times$ 2.1mm, 2.7 $\mu\text{m}$  ) or equivalent.
- Mobile Phase A: 0.1% Formic Acid in Water. (Causality: Low pH promotes protonation  $[\text{M}+\text{H}]^+$  for robust positive-mode Electrospray Ionization).
- Mobile Phase B: 0.1% Formic Acid in Methanol.
- Gradient: 5% B (hold 1 min)  $\rightarrow$  ramp to 60% B over 6 mins  $\rightarrow$  ramp to 95% B over 1 min  $\rightarrow$  hold 2 mins  $\rightarrow$  re-equilibrate at 5% B. Flow rate: 0.4mL/min .
- MS Mode: Positive Electrospray Ionization (ESI+), Multiple Reaction Monitoring (MRM).

## Data Presentation & Validation Parameters

The following tables summarize the quantitative parameters necessary for establishing the self-validating system.

## Table 1: MRM Transitions and MS Parameters for Target Cathinones

Analyte	Precursor Ion (m/z)	Quantifier Ion (m/z)	Qualifier Ion (m/z)	Collision Energy (eV)
Mephedrone (4-MMC)	178.1	160.1	145.1	15 / 25
3-MMC	178.1	160.1	145.1	15 / 25
MDPV	276.2	126.1	175.1	20 / 25
α-PVP	232.2	126.1	91.1	20 / 30
Methylone	208.1	160.1	132.1	15 / 20
Mephedrone-d3 (IS)	181.1	163.1	-	15
α-PVP-d8 (IS)	240.3	134.2	-	20

(Note: While 3-MMC and 4-MMC share identical MRM transitions, they are unambiguously identified via their distinct retention times achieved by the biphenyl column).

## Table 2: Method Validation Parameters across Biofluids

Matrix	Extraction Method	LOD (ng/mL)	LOQ (ng/mL)	Linearity (ng/mL)	Mean Recovery (%)
Urine	Dilute-and-Shoot	1.0 - 5.0	5.0	5.0 - 500	N/A (Direct)
Urine	SPE (MCX)	0.04 - 0.16	0.1 - 0.5	0.5 - 250	85 - 98%
Blood	PPT + SPE (MCX)	0.1 - 2.0	2.0 - 5.0	5.0 - 250	75 - 92%

## Conclusion

The reliable identification of synthetic cathinones in biofluids demands an analytical strategy that anticipates the chemical behavior of the analytes. By leveraging the  $\pi$ - $\pi$  selectivity of biphenyl chromatography to resolve positional isomers, and employing mixed-mode cation exchange with targeted acidification to maximize recovery, this LC-MS/MS protocol provides a highly sensitive, self-validating framework suitable for rigorous clinical and forensic toxicology applications.

## References

- Maas, A., Sydow, K., Madea, B., & Hess, C. (2017). Separation of ortho, meta and para isomers of methylmethcathinone (MMC) and methylethcathinone (MEC) using LC-ESI-MS/MS: Application to forensic serum samples. PubMed. Available at:[\[Link\]](#)
- Aldubayyan, A. A., Castrignanò, E., & Elliott, S. (2022). Development and validation of a chiral LC-MS/MS method for the separation and quantification of four synthetic cathinones in human whole blood and its application in stability analysis. King's College London. Available at:[\[Link\]](#)
- Roy, D., Colyer, C. L., & Mellinger, A. L. (2023). Liquid Chromatography Tandem Mass Spectrometry Method for Novel Psychoactive Substances: Kratom and Synthetic Cathinones in Urine. LCGC International. Available at:[\[Link\]](#)
- Pascual-Caro, S., et al. (2020). Determination of Synthetic Cathinones in Urine and Oral Fluid by Liquid Chromatography High-Resolution Mass Spectrometry and Low-Resolution Mass Spectrometry: A Method Comparison. MDPI. Available at:[\[Link\]](#)
- Al-Awadhi, A., et al. (2018). A Quantitative LC-MS/MS Method for the Detection of 16 Synthetic Cathinones and 10 Metabolites and Its Application to Suspicious Clinical and Forensic Urine Samples. PMC. Available at:[\[Link\]](#)

### Need Custom Synthesis?

BenchChem offers custom synthesis for rare earth carbides and specific isotopic labeling.

Email: [info@benchchem.com](mailto:info@benchchem.com) or [Request Quote Online](#).

## Sources

- [1. A Quantitative LC–MS/MS Method for the Detection of 16 Synthetic Cathinones and 10 Metabolites and Its Application to Suspicious Clinical and Forensic Urine Samples - PMC \[pmc.ncbi.nlm.nih.gov\]](#)
- [2. Separation of ortho, meta and para isomers of methylmethcathinone \(MMC\) and methylethcathinone \(MEC\) using LC-ESI-MS/MS: Application to forensic serum samples - PubMed \[pubmed.ncbi.nlm.nih.gov\]](#)
- [3. kclpure.kcl.ac.uk \[kclpure.kcl.ac.uk\]](#)
- [4. mdpi.com \[mdpi.com\]](#)
- [5. chromatographyonline.com \[chromatographyonline.com\]](#)
- To cite this document: BenchChem. [Application Note: High-Sensitivity LC-MS/MS Identification of Synthetic Cathinones in Biofluids]. BenchChem, [2026]. [Online PDF]. Available at: [<https://www.benchchem.com/product/b2691018/docs#application-note-high-sensitivity-lc-ms-ms-identification-of-synthetic-cathinones-in-biofluids>]

---

### Disclaimer & Data Validity:

The information provided in this document is for Research Use Only (RUO) and is strictly not intended for diagnostic or therapeutic procedures. While BenchChem strives to provide accurate protocols, we make no warranties, express or implied, regarding the fitness of this product for every specific experimental setup.

**Technical Support:** The protocols provided are for reference purposes. Unsure if this reagent suits your experiment?

**Need Industrial/Bulk Grade?** [Request Custom Synthesis Quote](#)

# BenchChem

Our mission is to be the trusted global source of essential and advanced chemicals, empowering scientists and researchers to drive progress in science and industry.

## Contact

Address: 3281 E Guasti Rd

Ontario, CA 91761, United States

Phone: (601) 213-4426

Email: [info@benchchem.com](mailto:info@benchchem.com)

[Contact our Ph.D. Support Team for a compatibility check](#)