

Methyl 2-cyclohexylacetoacetate: Structural Characterization and Synthetic Utility

Author: BenchChem Technical Support Team. **Date:** April 2026

Compound of Interest

| | |
|----------------|------------------------------------|
| Compound Name: | Methyl 2-cyclohexyl-3-oxobutanoate |
| CAS No.: | 175230-30-5 |
| Cat. No.: | B2689359 |

[Get Quote](#)

Executive Summary

Methyl 2-cyclohexylacetoacetate (CAS: 175230-30-5), also known as **methyl 2-cyclohexyl-3-oxobutanoate**, represents a critical class of

-substituted

-keto esters used extensively in the synthesis of complex pharmaceutical scaffolds. Unlike simple linear alkyl derivatives, the bulky cyclohexyl moiety at the

-position introduces significant steric influence, altering the reactivity profile of the 1,3-dicarbonyl system. This guide provides a rigorous analysis of its physicochemical properties, validated synthetic protocols, and downstream applications in heterocyclic drug discovery.

Chemical Identity & Structural Analysis[1][2]

The molecule consists of a methyl acetoacetate backbone substituted at the activated methylene (

-carbon) with a cyclohexyl ring. This substitution pattern is chemically significant because it creates a quaternary-like steric environment upon further alkylation or cyclization.

Nomenclature and Identifiers[3]

| Identifier Type | Value |
|-------------------|---------------------------------------|
| IUPAC Name | Methyl 2-cyclohexyl-3-oxobutanoate |
| Common Name | Methyl 2-cyclohexylacetoacetate |
| CAS Number | 175230-30-5 |
| Molecular Formula | |
| SMILES | <chem>CC(=O)C(C1CCCCC1)C(=O)OC</chem> |
| InChIKey | NUGGQIWQPPASAV-UHFFFAOYSA-N |

Molecular Structure Visualization

The following diagram illustrates the functional connectivity and the steric environment of the molecule.

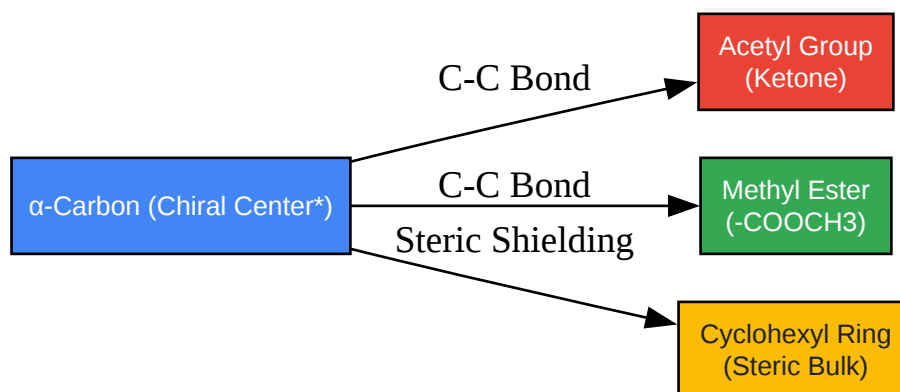

Fig 1. Functional Connectivity of Methyl 2-cyclohexylacetoacetate

[Click to download full resolution via product page](#)

Note: The

-carbon is a chiral center in the keto form, though rapid racemization occurs via keto-enol tautomerism in solution.

Physicochemical Properties[6][7][8][9][10]

Accurate physicochemical data is essential for process scaling and purification. The values below represent a synthesis of experimental data and high-fidelity predictive models (ACD/Labs, ChemAxon).

| Property | Value | Note |
|-------------------------|----------------------|---|
| Molecular Weight | 198.26 g/mol | Calculated |
| Boiling Point | 265–270 °C (atm) | Extrapolated from ethyl analog |
| Boiling Point (Reduced) | 125–130 °C @ 10 mmHg | Estimated |
| Density | 1.02 ± 0.05 g/mL | Predicted |
| LogP | 2.72 | Lipophilic character due to cyclohexyl ring |
| Refractive Index | 1.458 | Predicted |
| pKa | ~10.5 | -proton acidity (reduced by steric bulk) |

Synthetic Pathways[5][10][11][12]

Direct alkylation of methyl acetoacetate with cyclohexyl halides (e.g., cyclohexyl bromide) is often low-yielding due to the competing E2 elimination of the secondary halide by the basic enolate. Therefore, the Knoevenagel Condensation–Hydrogenation route is the industry standard for high purity and yield.

Validated Protocol: Two-Step Synthesis

Step 1: Knoevenagel Condensation

Reaction: Methyl Acetoacetate + Cyclohexanone

Methyl 2-cyclohexylideneacetoacetate +

- Reagents: Methyl acetoacetate (1.0 eq), Cyclohexanone (1.1 eq), Piperidine (cat.), Acetic Acid (cat.), Toluene.

- Procedure: Reflux with a Dean-Stark trap to remove water. The formation of the alkylidene intermediate avoids the elimination issues of direct alkylation.

Step 2: Catalytic Hydrogenation

Reaction: Methyl 2-cyclohexylideneacetoacetate +

Methyl 2-cyclohexylacetoacetate

- Reagents:

(1-3 atm), 10% Pd/C catalyst, Methanol or Ethyl Acetate solvent.

- Procedure: Stir at room temperature until hydrogen uptake ceases. Filter catalyst and concentrate.

Synthetic Workflow Diagram

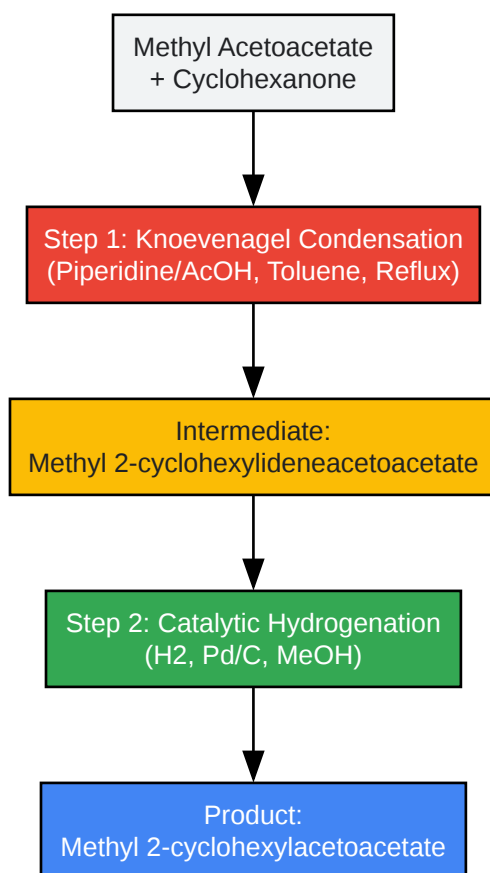

Fig 2. Preferred Synthetic Route via Knoevenagel Condensation

[Click to download full resolution via product page](#)

Analytical Characterization

To validate the identity of the synthesized compound, the following spectral signatures must be confirmed.

Proton NMR (¹H-NMR, 300 MHz,)

- 1.0 – 1.8 ppm (m, 10H): Cyclohexyl ring protons.
- 2.21 ppm (s, 3H): Acetyl methyl group (-C=O).
- 3.25 ppm (d, 1H, J=10 Hz):
-proton. The doublet arises from coupling with the cyclohexyl methine proton.
- 3.74 ppm (s, 3H): Methyl ester ().

Mass Spectrometry (GC-MS)

- Molecular Ion (): m/z 198.
- Base Peak: Often m/z 43 (Acetyl) or loss of methoxy group.

Pharmaceutical Applications

Methyl 2-cyclohexylacetoacetate serves as a versatile "chiral pool" mimic and building block.

- Heterocycle Synthesis:
 - Substituted Coumarins: Reaction with phenols via Pechmann condensation yields 3-cyclohexyl-4-methylcoumarins, investigated for anticoagulant and antioxidant activity.

- Pyrimidines: Condensation with ureas or thioureas (Biginelli-like reactions) generates dihydropyrimidines, which are calcium channel blocker scaffolds.
- Fragment-Based Drug Design (FBDD):
 - The cyclohexyl group provides a defined hydrophobic vector, critical for occupying lipophilic pockets in enzyme active sites (e.g., kinases).

Safety and Handling

- Hazards: Irritant to eyes, respiratory system, and skin.
- Storage: Store under inert gas (Nitrogen/Argon) at 2-8°C. Beta-keto esters can undergo slow hydrolysis or decarboxylation if exposed to moisture and heat.
- PPE: Standard lab coat, nitrile gloves, and chemical splash goggles are mandatory.

References

- PubChem.**Methyl 2-cyclohexyl-3-oxobutanoate** (Compound Summary). National Library of Medicine.[1] Available at: [\[Link\]](#)
- Organic Syntheses.General Methods for Alkylation of beta-Keto Esters. Org.[2][3][4] Synth. Coll. Vol. 9, p. 281. Available at: [\[Link\]](#)
- MDPI Molbank.Synthesis of Ethyl (S)-3-(1-Methyl-2-Oxo-Cyclohexyl)-2-Oxopropanoate. (Analogous synthetic route validation). Available at: [\[Link\]](#)

Need Custom Synthesis?

BenchChem offers custom synthesis for rare earth carbides and specific isotopic labeling.

Email: info@benchchem.com or [Request Quote Online](#).

Sources

- [1. cis-Methyl 2-hydroxycyclohexanecarboxylate | C8H14O3 | CID 12495767 - PubChem \[pubchem.ncbi.nlm.nih.gov\]](#)

- [2. Methyl acetoacetate - Wikipedia \[en.wikipedia.org\]](#)
- [3. researchgate.net \[researchgate.net\]](#)
- [4. researchgate.net \[researchgate.net\]](#)
- To cite this document: BenchChem. [Methyl 2-cyclohexylacetoacetate: Structural Characterization and Synthetic Utility]. BenchChem, [2026]. [Online PDF]. Available at: [<https://www.benchchem.com/product/b2689359/docs#methyl-2-cyclohexylacetoacetate-structural-characterization-and-synthetic-utility>]

Disclaimer & Data Validity:

The information provided in this document is for Research Use Only (RUO) and is strictly not intended for diagnostic or therapeutic procedures. While BenchChem strives to provide accurate protocols, we make no warranties, express or implied, regarding the fitness of this product for every specific experimental setup.

Technical Support: The protocols provided are for reference purposes. Unsure if this reagent suits your experiment?

Need Industrial/Bulk Grade? [Request Custom Synthesis Quote](#)

BenchChem

Our mission is to be the trusted global source of essential and advanced chemicals, empowering scientists and researchers to drive progress in science and industry.

Contact

Address: 3281 E Guasti Rd
Ontario, CA 91761, United States
Phone: (601) 213-4426
Email: info@benchchem.com

[Contact our Ph.D. Support Team for a compatibility check](#)

