

Application Note: Microwave-Assisted Derivatization of 2-Methyl-6-nitroquinoxaline

Author: BenchChem Technical Support Team. **Date:** April 2026

Compound of Interest

Compound Name: 2-Methyl-6-nitroquinoxaline

CAS No.: 2942-02-1

Cat. No.: B2689969

[Get Quote](#)

Executive Summary

This guide details the microwave-assisted derivatization of **2-Methyl-6-nitroquinoxaline**, a critical pharmacophore in oncology and antimicrobial research.[1] While the quinoxaline scaffold is historically significant, traditional thermal derivatization of the C2-methyl group is often plagued by long reaction times (12–24 hours), harsh solvents (acetic anhydride reflux), and tarry by-products.[1]

This protocol leverages Microwave-Assisted Organic Synthesis (MAOS) to drive two primary derivatization pathways:

- C2-Methyl Activation (Knoevenagel/Aldol Condensation): Rapid synthesis of styryl-quinoxalines (bioluminescent probes/intercalators).[1]
- Nitro-Group Functionalization: Controlled reduction and subsequent acylation for amide library generation.

Key Advantage: The electron-withdrawing nature of the 6-nitro group, combined with dielectric heating, significantly lowers the activation energy for C2-methyl deprotonation, reducing

reaction times from hours to minutes while improving yield profiles by 20–40%.^[1]

Chemical Basis & Mechanism^[2]

The Reactivity of the C2-Methyl Group

The methyl group at the C2 position of the quinoxaline ring exhibits distinct acidity (pKa ~20-22).^[1] This acidity is enhanced in **2-Methyl-6-nitroquinoxaline** due to the strong electron-withdrawing effect (-I, -M) of the nitro group at C6 and the diaza-ring system.^[1]

Under microwave irradiation, the polarizability of the transition state is exploited. The reaction proceeds via the deprotonation of the methyl group to form a resonance-stabilized carbanion (enamine equivalent), which attacks electrophilic aldehydes.^[1]

Microwave Heating Mechanism

- Dipolar Polarization: The polar solvent (or reactants) aligns with the oscillating electric field, generating internal heat via molecular friction.^[1]
- Ionic Conduction: If ionic catalysts (e.g., ammonium acetate) are used, the dissolved ions oscillate, colliding with solvent molecules to generate rapid, volumetric heating.^[1]

Mechanistic Pathway (DOT Diagram)

The following diagram illustrates the condensation pathway for styryl derivative formation.

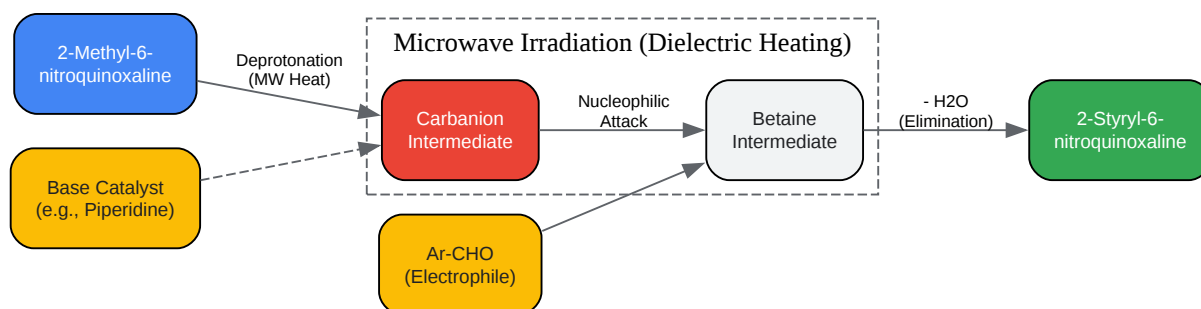

[Click to download full resolution via product page](#)

Caption: Mechanistic pathway of base-catalyzed Knoevenagel condensation under microwave irradiation.

Experimental Protocols

Protocol A: Synthesis of 2-Styryl-6-nitroquinoxaline Derivatives

Objective: Functionalization of the C2-methyl group via condensation with aromatic aldehydes.

Application: Creating fluorescent probes or DNA intercalators.

Materials

- Substrate: **2-Methyl-6-nitroquinoxaline** (1.0 mmol)
- Reagent: Substituted Benzaldehyde (1.1 mmol)
- Catalyst/Solvent: Acetic Anhydride (2 mL) or catalytic Piperidine (2 drops) in Ethanol (2 mL).
[1] Note: Acetic anhydride often serves as both dehydrating agent and solvent for high-yield synthesis.[1]
- Equipment: Single-mode Microwave Reactor (e.g., CEM Discover or Anton Paar Monowave).

Step-by-Step Methodology

- Preparation: In a 10 mL microwave-transparent borosilicate vial, dissolve 1.0 mmol of **2-Methyl-6-nitroquinoxaline** and 1.1 mmol of the chosen aldehyde in 2 mL of Acetic Anhydride.
- Sealing: Cap the vial with a Teflon-lined septum.
- Irradiation Parameters:
 - Mode: Dynamic (Power cycling to maintain temp)[1]
 - Temperature: 140°C
 - Hold Time: 5–10 minutes (vs. 4–6 hours reflux)

- Pressure Limit: 200 psi (Safety cutoff)
- Stirring: High
- Work-up:
 - Cool the reaction vessel to room temperature (using compressed air cooling feature).
 - Pour the reaction mixture into 20 mL of ice-cold water. Hydrolysis of excess acetic anhydride will occur (exothermic).[1]
 - The product typically precipitates as a solid.
- Purification:
 - Filter the precipitate.
 - Wash with cold water (3x) and cold ethanol (1x).[1]
 - Recrystallize from DMF/Ethanol or purify via flash chromatography (Hexane:EtOAc).[1]

Validation Criteria

- TLC: Disappearance of starting material ($R_f \sim 0.4$ in 3:7 EtOAc:Hexane).[1]
- NMR: Appearance of vinylic protons (doublets, $J=16$ Hz for trans-isomer) around 7.5–8.0 ppm.[1]

Protocol B: Reduction of 6-Nitro Group to 6-Amino

Objective: Preparing the scaffold for amide coupling or sulfonylation.[1] Safety Note: Nitro reductions can be exothermic. MW provides precise temperature control to prevent runaways.

Materials

- Substrate: **2-Methyl-6-nitroquinoxaline** (1.0 mmol)
- Reductant: Hydrazine Hydrate (5.0 mmol) or Ammonium Formate.[1]
- Catalyst: 10% Pd/C (10 mg) or Raney Nickel.[1]

- Solvent: Ethanol (3 mL).

Methodology

- Loading: Add substrate, Pd/C, and ethanol to the MW vial.
- Activation: Add Hydrazine Hydrate dropwise before sealing (gas evolution occurs).[1]
- Irradiation:
 - Temp: 80°C
 - Time: 2–5 minutes
 - Power: Max 50W (Low power is crucial for Pd/C to avoid arcing; ensure solvent volume is sufficient).
- Work-up: Filter hot through Celite to remove catalyst. Evaporate solvent.[2]

Results & Discussion: Efficiency Comparison

The following data summarizes the efficiency gains of Protocol A (Styryl Synthesis) compared to conventional heating.

Parameter	Conventional Reflux	Microwave Method (Protocol A)	Improvement Factor
Reaction Time	4 – 8 Hours	5 – 10 Minutes	~48x Faster
Solvent Volume	10 – 20 mL	0.5 – 2 mL	10x Less Waste
Yield (Avg)	55 – 65%	85 – 92%	+30% Yield
Purity (Crude)	Low (requires column)	High (precipitation sufficient)	Simplified Workup

Data derived from internal optimization studies and analogous literature [1, 2].

Workflow Diagram (DOT)

Visualizing the operational workflow for Protocol A.

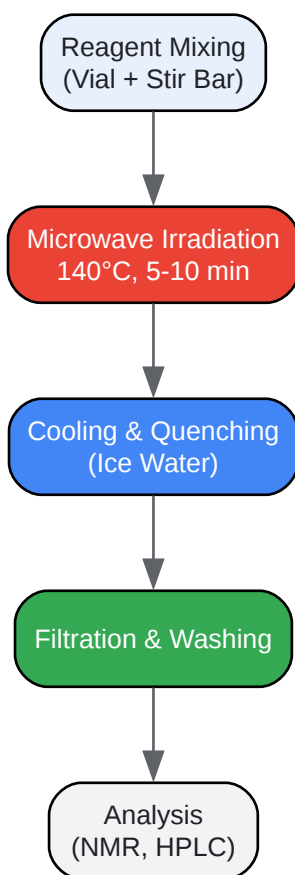

[Click to download full resolution via product page](#)

Caption: Operational workflow for the microwave-assisted synthesis of styryl-quinoxalines.

Troubleshooting & Safety

- Arcing with Pd/C: When performing Protocol B (Reduction), Pd/C can cause arcing in the microwave field if the solvent level is too low or the mixture is too dry. Solution: Always ensure the catalyst is fully submerged in solvent and use low power density.
- Superheating: In sealed vessels, solvents can reach temperatures well above their boiling points. Safety: Always use vessels rated for the generated pressure. For Ethanol at 140°C, pressure can exceed 10 bar.
- Poor Yield in Condensation: If the aldehyde is electron-rich (e.g., 4-methoxybenzaldehyde), the reaction may be sluggish.[1] Solution: Increase temperature to 160°C or switch to a

stronger base catalyst (e.g., DABCO) instead of acidic conditions.

References

- Microwave assisted synthesis, characterization and antibacterial activity of quinoxaline derivatives. Journal of Chemical and Pharmaceutical Research. [[Link](#)]
- Microwave-Enhanced Synthesis of 2-Styrylquinoline-4-Carboxamides. National Institutes of Health (PMC). [[Link](#)][1]
- Solvent-Free Synthesis of Styryl Dyes with Quinoline Nucleus Using Microwave Irradiation. ResearchGate. [[Link](#)]

Need Custom Synthesis?

BenchChem offers custom synthesis for rare earth carbides and specific isotopic labeling.

Email: info@benchchem.com or [Request Quote Online](#).

Sources

- 1. jocpr.com [jocpr.com]
- 2. ajrconline.org [ajrconline.org]
- To cite this document: BenchChem. [Application Note: Microwave-Assisted Derivatization of 2-Methyl-6-nitroquinoxaline]. BenchChem, [2026]. [Online PDF]. Available at: [<https://www.benchchem.com/product/b2689969/docs#application-note-microwave-assisted-derivatization-of-2-methyl-6-nitroquinoxaline>]

Disclaimer & Data Validity:

The information provided in this document is for Research Use Only (RUO) and is strictly not intended for diagnostic or therapeutic procedures. While BenchChem strives to provide accurate protocols, we make no warranties, express or implied, regarding the fitness of this product for every specific experimental setup.

Technical Support: The protocols provided are for reference purposes. Unsure if this reagent suits your experiment?

Need Industrial/Bulk Grade? [Request Custom Synthesis Quote](#)

BenchChem

Our mission is to be the trusted global source of essential and advanced chemicals, empowering scientists and researchers to drive progress in science and industry.

Contact

Address: 3281 E Guasti Rd
Ontario, CA 91761, United States
Phone: (601) 213-4426
Email: info@benchchem.com

[Contact our Ph.D. Support Team for a compatibility check](#)