

# A Comparative Guide to the Mass Spectrometry Fragmentation Patterns of Fluorinated Butanoates

**Author:** BenchChem Technical Support Team. **Date:** April 2026

## Compound of Interest

Compound Name:	<i>Ethyl 2,2-difluoro-3-hydroxy-3-phenylbutanoate</i>
CAS No.:	152123-58-5
Cat. No.:	B2689021

[Get Quote](#)

For Researchers, Scientists, and Drug Development Professionals

In the landscape of modern analytical chemistry, mass spectrometry (MS) stands as a cornerstone for the structural elucidation of novel compounds. For professionals in pharmaceutical development and materials science, understanding the fragmentation behavior of fluorinated molecules is of paramount importance. Fluorination can dramatically alter a molecule's pharmacokinetic and physicochemical properties, and thus, its behavior in a mass spectrometer. This guide provides an in-depth comparison of the electron ionization (EI) mass spectrometry fragmentation patterns of fluorinated butanoates, offering insights into how the position and degree of fluorination influence ion formation.

## The Fundamental Fragmentation Pathways of Butanoate Esters

Before delving into the effects of fluorination, it is crucial to understand the primary fragmentation routes of a simple butanoate ester, such as ethyl butanoate, under electron ionization. The fragmentation of such esters is dominated by two principal mechanisms: alpha-cleavage and the McLafferty rearrangement.

## Alpha-Cleavage

Alpha-cleavage involves the homolytic cleavage of a bond adjacent to the carbonyl group. For ethyl butanoate, this can occur on either side of the carbonyl, leading to the formation of several characteristic ions. This process is a direct result of the ionization of a non-bonding electron on the oxygen atom, which weakens the adjacent bonds.

## McLafferty Rearrangement

The McLafferty rearrangement is a hallmark of carbonyl compounds possessing a gamma-hydrogen. It is a six-membered ring rearrangement that results in the elimination of a neutral alkene molecule and the formation of a resonance-stabilized radical cation.<sup>[1][2][3]</sup> This rearrangement is highly specific and provides significant structural information. For ethyl butanoate, this rearrangement leads to a prominent peak at  $m/z$  88.<sup>[1]</sup>

## The Influence of Fluorination on Fragmentation Patterns

The introduction of highly electronegative fluorine atoms into the butanoate structure significantly alters the fragmentation landscape. The position and number of fluorine atoms can stabilize or destabilize certain radical cations, favoring or inhibiting specific fragmentation pathways.

## Comparative Analysis of Monofluorinated Ethyl Butanoates

To illustrate the effect of the fluorine position, we will compare the hypothetical and known fragmentation patterns of ethyl 2-fluorobutanoate, ethyl 3-fluorobutanoate, and ethyl 4-fluorobutanoate.

Table 1: Key Predicted and Observed Fragment Ions for Monofluorinated Ethyl Butanoate Isomers

Ion (m/z)	Proposed Structure	Ethyl 2-Fluorobutanoate	Ethyl 3-Fluorobutanoate (Predicted)	Ethyl 4-Fluorobutanoate (Predicted)	Fragmentation Pathway
134	$[C_6H_{11}FO_2]^+\bullet$	Present (Molecular Ion)	Present (Molecular Ion)	Present (Molecular Ion)	Molecular Ion
105	$[M - C_2H_5]^+$	Observed	Likely	Likely	$\alpha$ -cleavage (loss of ethyl radical)
89	$[M - OCH_2CH_3]^+$	Observed	Likely	Likely	$\alpha$ -cleavage (loss of ethoxy radical)
88	$[C_4H_5FO_2]^+\bullet$	Absent or Weak	Likely	Present	McLafferty Rearrangement
69	$[CF_3CH_2CH_2]^+$	Absent	Absent	Likely	Cleavage related to $CF_3$ group
45	$[C_2H_5O]^+$	Observed	Likely	Likely	Cleavage of the ester bond

#### Ethyl 2-Fluorobutanoate:

The mass spectrum of ethyl 2-fluorobutanoate is available in the NIST WebBook.<sup>[4]</sup> The fluorine atom at the alpha-position significantly influences the fragmentation. The presence of the electronegative fluorine atom on the  $\alpha$ -carbon can disfavor the typical McLafferty rearrangement, as it alters the electron distribution and stability of the resulting radical cation.

Instead,  $\alpha$ -cleavages leading to the loss of the ethyl radical ( $m/z$  105) and the ethoxy radical ( $m/z$  89) are prominent.

Ethyl 3-Fluorobutanoate (Predicted):

With the fluorine atom at the beta-position, the McLafferty rearrangement is expected to be more favorable compared to the 2-fluoro isomer, as the gamma-hydrogens are unaffected. We would anticipate a significant peak at  $m/z$  88. Alpha-cleavages would still occur.

Ethyl 4-Fluorobutanoate (Predicted):

In this isomer, the fluorine atom is on the gamma-carbon. This has a profound effect on the McLafferty rearrangement. The transfer of a now-fluorinated gamma-carbon's hydrogen is less likely. However, alternative fragmentations involving the C-F bond may become more prominent.

## The Impact of Multiple Fluorine Atoms: The Case of Ethyl 4,4,4-trifluorobutanoate

The presence of multiple fluorine atoms, as in ethyl 4,4,4-trifluorobutanoate, further directs the fragmentation. The highly stable trifluoromethyl group ( $CF_3$ ) plays a dominant role.

Table 2: Key Fragment Ions for Ethyl 4,4,4-trifluorobutanoate

Ion ( $m/z$ )	Proposed Structure	Relative Abundance	Fragmentation Pathway
170	$[C_6H_9F_3O_2]^+$	Low	Molecular Ion
125	$[M - OCH_2CH_3]^+$	High	$\alpha$ -cleavage (loss of ethoxy radical)
97	$[CF_3CH_2CO]^+$	Moderate	Cleavage of the C-C bond beta to the carbonyl
69	$[CF_3]^+$	High	Cleavage yielding the trifluoromethyl cation

In the spectrum of ethyl 4,4,4-trifluorobutanoate, the molecular ion is often weak. The base peak is frequently at  $m/z$  69, corresponding to the very stable  $[CF_3]^+$  cation. The loss of the ethoxy group ( $m/z$  125) is also a major fragmentation pathway. The McLafferty rearrangement is generally suppressed in this molecule due to the strong C-F bonds and the deactivating effect of the  $CF_3$  group on the gamma-hydrogens.

## Experimental Protocols

Acquiring high-quality mass spectra is fundamental to accurate structural elucidation. The following is a generalized protocol for the analysis of fluorinated butanoates by gas chromatography-mass spectrometry (GC-MS).

### Sample Preparation

- **Standard Preparation:** Prepare a 1 mg/mL stock solution of the fluorinated butanoate standard in a high-purity solvent such as ethyl acetate or dichloromethane.
- **Working Solution:** Dilute the stock solution to a final concentration of 10-100  $\mu\text{g/mL}$  in the same solvent.
- **Sample Injection:** Inject 1  $\mu\text{L}$  of the working solution into the GC-MS system.

### GC-MS Parameters

- **Gas Chromatograph:** Agilent 7890B GC or equivalent.
- **Column:** HP-5ms (30 m x 0.25 mm, 0.25  $\mu\text{m}$  film thickness) or equivalent non-polar column.
- **Inlet Temperature:** 250  $^{\circ}\text{C}$ .
- **Injection Mode:** Split (10:1 ratio).
- **Oven Program:**
  - Initial temperature: 50  $^{\circ}\text{C}$ , hold for 2 minutes.
  - Ramp: 10  $^{\circ}\text{C}/\text{min}$  to 250  $^{\circ}\text{C}$ .
  - Hold: 5 minutes at 250  $^{\circ}\text{C}$ .

- Carrier Gas: Helium at a constant flow of 1.0 mL/min.
- Mass Spectrometer: Agilent 5977A MSD or equivalent.
- Ionization Mode: Electron Ionization (EI) at 70 eV.
- Source Temperature: 230 °C.
- Quadrupole Temperature: 150 °C.
- Mass Range: m/z 40-400.

## Visualizing Fragmentation Pathways

The following diagrams, generated using Graphviz (DOT language), illustrate the key fragmentation pathways discussed.

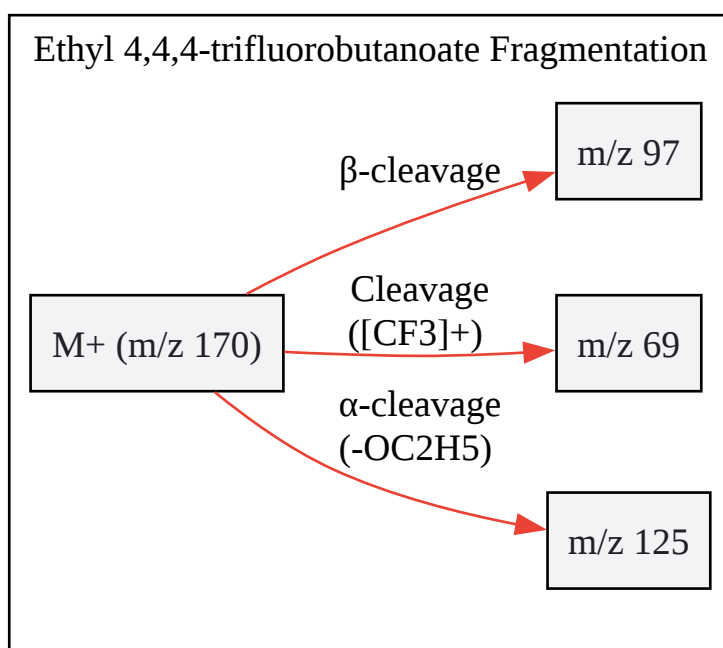
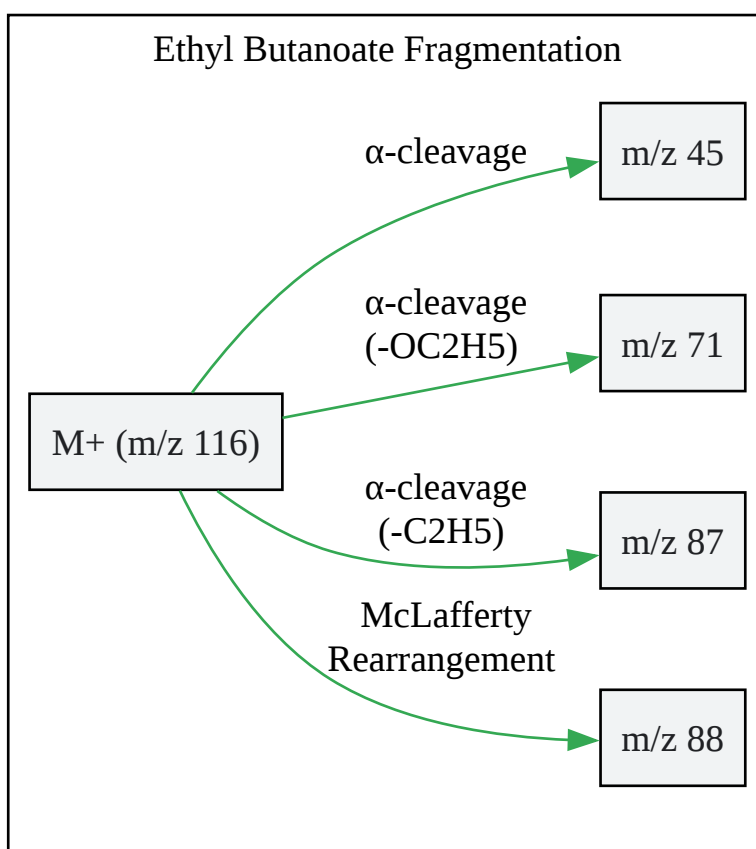

[Click to download full resolution via product page](#)

Caption: Dominant fragmentation pathways of ethyl 4,4,4-trifluorobutanoate.

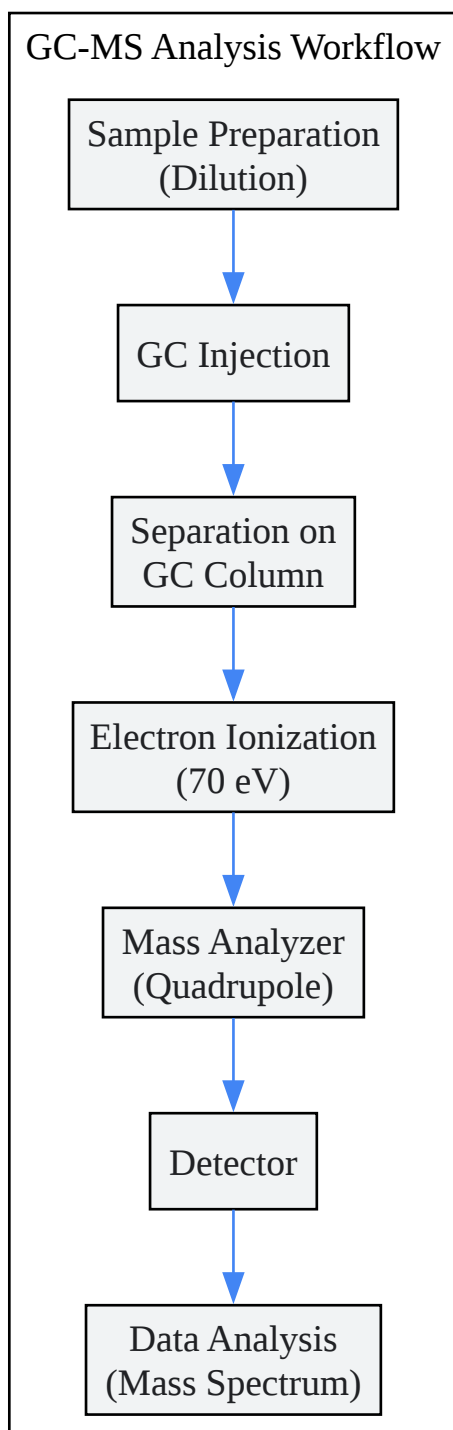

[Click to download full resolution via product page](#)

Caption: General workflow for GC-MS analysis of fluorinated butanoates.

## Conclusion

The mass spectrometric fragmentation of fluorinated butanoates is a complex process governed by the interplay of fundamental ester fragmentation mechanisms and the profound electronic effects of fluorine substitution. As demonstrated, the position and degree of fluorination dictate the preferred fragmentation pathways. For monofluorinated isomers, the proximity of the fluorine atom to the carbonyl group can significantly inhibit the McLafferty rearrangement. In highly fluorinated analogues, such as ethyl 4,4,4-trifluorobutanoate, fragmentation is dominated by the formation of stable fluorinated carbocations like  $[\text{CF}_3]^+$ . A thorough understanding of these patterns, supported by robust experimental data, is essential for the confident identification and structural elucidation of these important molecules in various scientific and industrial applications.

## References

- National Center for Biotechnology Information (2024). PubChem Compound Summary for CID 285092, Ethyl 2-fluorobutyrate. Retrieved from [\[Link\]](#).
- NIST Mass Spectrometry Data Center, S.E. Stein, director, "Mass Spectra" in NIST Chemistry WebBook, NIST Standard Reference Database Number 69, Eds. P.J. Linstrom and W.G. Mallard, National Institute of Standards and Technology, Gaithersburg MD, 20899, [\[Link\]](#).
- McLafferty, F. W. (1959). Mass Spectrometric Analysis. Molecular Rearrangements. Analytical Chemistry, 31(1), 82–87.
- Sparkman, O. D. (2007). Mass Spectrometry Desk Reference. Global View Publishing.
- Filo. (2025, December 2). Fragmentation pattern of ethyl n butanoate. Retrieved from [\[Link\]](#)
- Chemistry Steps. (2025, September 30). McLafferty Rearrangement. Retrieved from [\[Link\]](#)
- Organic Chemistry Tutor. (n.d.). The McLafferty Rearrangement. Retrieved from [\[Link\]](#)
- Chemguide. (n.d.). Mass Spectra - Fragmentation Patterns. Retrieved from [\[Link\]](#)
- Dummies.com. (2021, July 26). How to Identify Molecular Fragmentation Patterns in Mass Spectrometry. Retrieved from [\[Link\]](#)

### Need Custom Synthesis?

BenchChem offers custom synthesis for rare earth carbides and specific isotopic labeling.

Email: [info@benchchem.com](mailto:info@benchchem.com) or [Request Quote Online](#).

## Sources

- [1. Fragmentation pattern of ethyl n butanoate | Filo \[askfilo.com\]](#)
- [2. Welcome to the NIST WebBook \[webbook.nist.gov\]](#)
- [3. organicchemistrytutor.com \[organicchemistrytutor.com\]](#)
- [4. Ethyl 2-fluorobutyrate | C6H11FO2 | CID 285092 - PubChem \[pubchem.ncbi.nlm.nih.gov\]](#)
- To cite this document: BenchChem. [A Comparative Guide to the Mass Spectrometry Fragmentation Patterns of Fluorinated Butanoates]. BenchChem, [2026]. [Online PDF]. Available at: [<https://www.benchchem.com/product/b2689021/docs#a-comparative-guide-to-the-mass-spectrometry-fragmentation-patterns-of-fluorinated-butanoates>]

---

### Disclaimer & Data Validity:

The information provided in this document is for Research Use Only (RUO) and is strictly not intended for diagnostic or therapeutic procedures. While BenchChem strives to provide accurate protocols, we make no warranties, express or implied, regarding the fitness of this product for every specific experimental setup.

**Technical Support:** The protocols provided are for reference purposes. Unsure if this reagent suits your experiment?

**Need Industrial/Bulk Grade?** [Request Custom Synthesis Quote](#)

# BenchChem

Our mission is to be the trusted global source of essential and advanced chemicals, empowering scientists and researchers to drive progress in science and industry.

## Contact

Address: 3281 E Guasti Rd

Ontario, CA 91761, United States

Phone: (601) 213-4426

Email: [info@benchchem.com](mailto:info@benchchem.com)

[Contact our Ph.D. Support Team for a compatibility check](#)