

Technical Support Center: Methylcyclobutane Bromination Strategies

Author: BenchChem Technical Support Team. **Date:** April 2026

Compound of Interest

Compound Name: 1-(Bromomethyl)-1,3-dimethylcyclobutane

CAS No.: 2106452-76-8

Cat. No.: B2681464

[Get Quote](#)

Welcome to the technical support center for the synthesis of brominated methylcyclobutanes. This guide provides researchers, scientists, and drug development professionals with in-depth answers, troubleshooting advice, and detailed protocols for alternatives to direct bromination. Our goal is to explain the causality behind experimental choices, ensuring you can select and execute the optimal synthetic route for your target molecule.

Frequently Asked Questions (FAQs)

Q1: Why should I consider alternatives to direct bromination of methylcyclobutane with molecular bromine (Br₂) and UV light?

While direct bromination of alkanes with Br₂ under UV irradiation is a classic method, it presents significant challenges for substrates like methylcyclobutane. The reaction proceeds via a free-radical chain mechanism, where a bromine radical abstracts a hydrogen atom from the alkane. The regioselectivity is dictated by the stability of the resulting alkyl radical. For

methylcyclobutane, there are four distinct types of C-H bonds, leading to a potential mixture of products.

The order of radical stability is tertiary > secondary > primary. Therefore, abstraction of the hydrogen from the tertiary carbon (C1, bonded to the methyl group) is kinetically favored, making 1-bromo-1-methylcyclobutane the major product. However, the reaction is often not perfectly selective, and competing abstraction at the secondary and primary positions can lead to a mixture of isomers, complicating purification and reducing the yield of the desired product.

Q2: I want to synthesize 1-bromo-1-methylcyclobutane. What is the most reliable method?

For selective synthesis of the tertiary bromide, 1-bromo-1-methylcyclobutane, the most effective method is a free-radical bromination using N-Bromosuccinimide (NBS) as the bromine source, often in a non-polar solvent like carbon tetrachloride (CCl₄) or dichloromethane (CH₂Cl₂), with a radical initiator such as azobisisobutyronitrile (AIBN) or benzoyl peroxide (BPO). This is known as the Wohl-Ziegler reaction.

NBS provides a low, constant concentration of molecular bromine (Br₂) throughout the reaction. This low concentration is crucial for selectivity. According to the Hammond Postulate, the highly reactive chlorine radical leads to an early, reactant-like transition state, making it less selective. The less reactive bromine radical leads to a later, product-like transition state that more closely reflects the stability of the radical intermediate, thus greatly favoring the formation of the most stable tertiary radical. This results in a significantly higher yield of 1-bromo-1-methylcyclobutane compared to using Br₂ directly.

Q3: My target is bromomethylcyclobutane. How can I selectively brominate the primary methyl group?

Direct radical bromination is unsuitable for this transformation, as it will preferentially occur at the tertiary position. To synthesize bromomethylcyclobutane, two primary alternative routes are recommended:

- **Substitution of a Hydroxyl Group:** The most straightforward method involves the conversion of cyclobutylmethanol to bromomethylcyclobutane. This can be achieved using various brominating agents like phosphorus tribromide (PBr₃) or thionyl bromide (SOBr₂). A patented

industrial-scale method describes the reaction of cyclobutylmethanol with a triarylphosphite and bromine in a polar aprotic solvent.

- The Hunsdiecker Reaction: This classic method converts a carboxylic acid into an alkyl halide with one less carbon atom via decarboxylation. For this synthesis, you would start with cyclobutylacetic acid. The acid is first converted to its silver salt, which is then treated with bromine. A more convenient modern variation, the Cristol-Firth-modified Hunsdiecker reaction, uses mercuric oxide and bromine directly with the carboxylic acid, avoiding the need to isolate the silver salt.

Q4: What is N-Bromosuccinimide (NBS) and how exactly does it improve selectivity?

N-Bromosuccinimide (NBS) is a crystalline solid reagent that serves as a source for bromine in radical reactions. Its primary advantage is providing a low, steady concentration of Br_2 . The reaction is initiated by trace amounts of HBr, which reacts with NBS to produce Br_2 . This Br_2 is then homolytically cleaved by light or a radical initiator to start the chain reaction. As Br_2 is consumed, more is generated from the NBS/HBr reaction, keeping its concentration low and constant. This prevents the high local concentrations of Br_2 that can lead to competing ionic side reactions, such as addition to any potential alkene impurities. This controlled delivery of bromine radicals is the key to achieving high regioselectivity for the most stable radical intermediate.

Q5: Are there non-radical methods to consider for producing brominated methylcyclobutanes?

Yes. As mentioned in Q3, nucleophilic substitution reactions are excellent non-radical alternatives. If you start with an alcohol, such as 1-methylcyclobutanol, you can convert it to 1-bromo-1-methylcyclobutane using an acid like HBr. This reaction proceeds via an SN_1 mechanism, where the hydroxyl group is protonated, leaves as a water molecule to form a stable tertiary carbocation, which is then attacked by the bromide ion. Similarly, converting cyclobutylmethanol to bromomethylcyclobutane with PBr_3 is an SN_2 reaction. These methods offer completely different selectivity rules compared to radical pathways and are often preferred when the corresponding alcohol is readily available.

Method Selection Guide

The following diagram provides a workflow for selecting the appropriate bromination method based on your desired product.

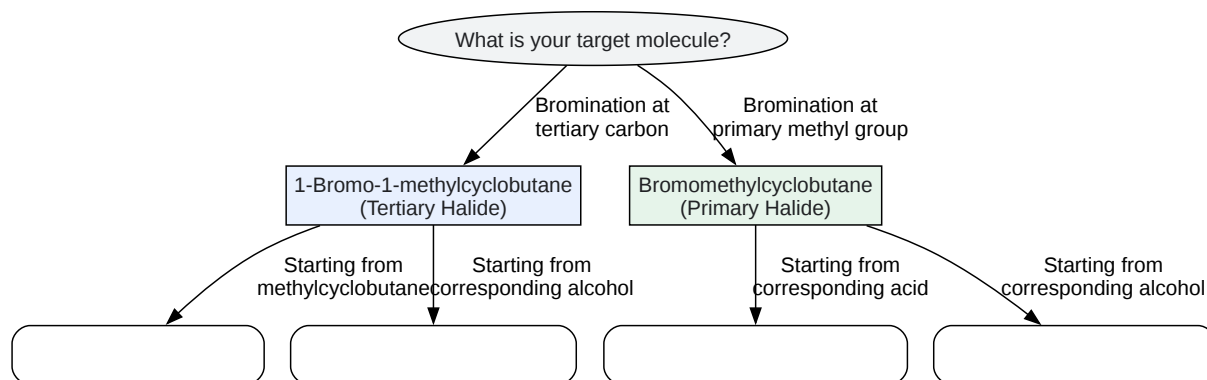

[Click to download full resolution via product page](#)

Caption: Decision tree for selecting a synthetic route.

Troubleshooting Guides

Problem	Potential Cause(s)	Recommended Solution(s)
Low or No Yield in NBS Bromination	<p>1. Decomposed NBS: NBS can degrade over time, especially if exposed to moisture. 2. Inactive Radical Initiator: AIBN or BPO can lose activity with age. 3. Reaction Not Initiated: Insufficient light (for photochemical initiation) or temperature (for thermal initiators). 4. Presence of Radical Inhibitors: Oxygen or other impurities in the solvent or on the glassware can quench the radical chain reaction.</p>	<p>1. Recrystallize NBS from water before use. 2. Use a fresh batch of AIBN or BPO. 3. Ensure the UV lamp is functional and close to the flask. For AIBN, ensure the reaction temperature is maintained at ~80 °C. 4. Degas the solvent by bubbling with nitrogen or argon. Ensure all glassware is thoroughly cleaned and dried.</p>
Formation of Multiple Isomers	<p>1. Reaction Temperature is Too High: Higher temperatures can decrease the selectivity of bromination. 2. High Concentration of Bromine: If NBS is added too quickly or decomposes, it can lead to higher Br₂ concentrations, mimicking direct bromination conditions.</p>	<p>1. Maintain the recommended reaction temperature. If using photochemical initiation, consider cooling the reaction vessel with a fan or water bath. 2. Add NBS portion-wise over the course of the reaction to maintain a low bromine concentration.</p>

Hunsdiecker Reaction Failure	<p>1. Wet Reagents/Solvent: The reaction is sensitive to water, which can hydrolyze intermediates. The silver salt must be perfectly dry. 2. Photosensitivity: Silver salts are light-sensitive and can decompose before the reaction begins. 3. Poor Quality Silver Salt: Incomplete formation of the silver carboxylate from the starting acid.</p>	<p>1. Thoroughly dry the carboxylic acid and silver salt under vacuum. Use anhydrous solvents. 2. Wrap the reaction flask in aluminum foil to exclude light. 3. Ensure complete conversion to the silver salt by checking the pH or using a slight excess of silver oxide and filtering.</p>
------------------------------	---	--

Detailed Experimental Protocols

Protocol 1: Wohl-Ziegler Bromination for the Synthesis of 1-Bromo-1-methylcyclobutane

This protocol details the selective bromination of methylcyclobutane at the tertiary position using N-Bromosuccinimide (NBS).

Mechanism Overview:

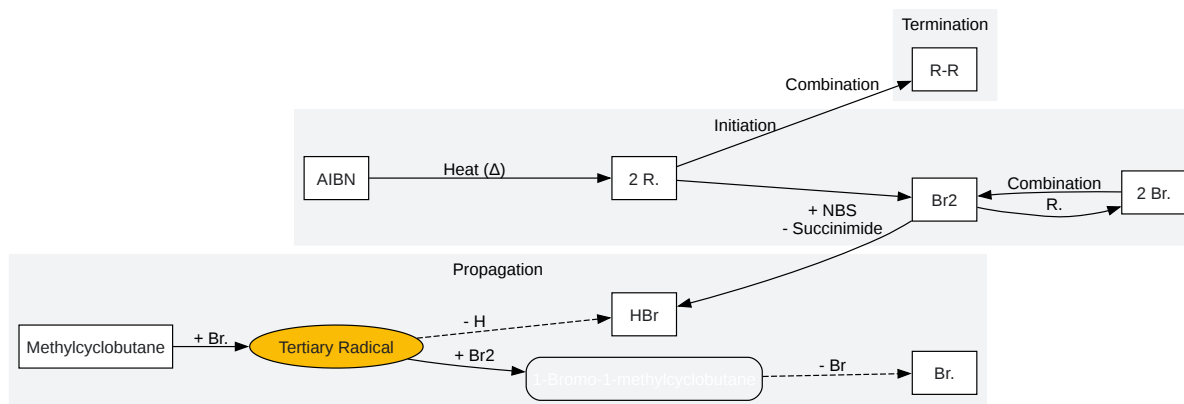

[Click to download full resolution via product page](#)

Caption: Radical chain mechanism for Wohl-Ziegler bromination.

Materials:

- Methylcyclobutane
- N-Bromosuccinimide (NBS), freshly recrystallized
- Carbon tetrachloride (CCl_4), anhydrous
- Azobisisobutyronitrile (AIBN)
- Saturated sodium bicarbonate (NaHCO_3) solution
- Saturated sodium thiosulfate ($\text{Na}_2\text{S}_2\text{O}_3$) solution

- Brine (saturated NaCl solution)
- Anhydrous magnesium sulfate (MgSO_4)

Procedure:

- Setup: To a dry, round-bottom flask equipped with a reflux condenser and a magnetic stir bar, add methylcyclobutane (1.0 eq), N-bromosuccinimide (1.1 eq), and anhydrous CCl_4 .
- Initiation: Add a catalytic amount of AIBN (0.05 eq).
- Reaction: Heat the mixture to reflux (approx. $77\text{ }^\circ\text{C}$) with vigorous stirring. The reaction can be monitored by GC or TLC (by observing the disappearance of the starting material). The reaction is typically complete within 1-3 hours.
- Work-up: Cool the reaction mixture to room temperature. The succinimide byproduct will precipitate. Filter the solid and wash it with a small amount of cold CCl_4 .
- Washing: Transfer the filtrate to a separatory funnel. Wash sequentially with saturated NaHCO_3 solution (to remove HBr), saturated $\text{Na}_2\text{S}_2\text{O}_3$ solution (to remove any remaining Br_2), and brine.
- Drying and Concentration: Dry the organic layer over anhydrous MgSO_4 , filter, and remove the solvent by rotary evaporation.
- Purification: The crude product can be purified by fractional distillation under reduced pressure to yield pure 1-bromo-1-methylcyclobutane.

References

- Filo. (2025). What is the major product P when methylcyclobutane (CH_3 attach...
- Quora. (2020). What is the chlorination product of 1-methylcyclobutane?.
- Lampman, G. M., & Aumiller, J. C. (n.d.). MERCURY(II) OXIDE-MODIFIED HUNSDIECKER REACTION: 1-BROMO-3-CHLOROCYCLOBUTANE. Organic Syntheses Procedure. Retrieved from [[Link](#)]
- Chegg. (2023). Solved 2) Bromination of methylcyclobutane yields a single.

- Organic Chemistry Portal. (n.d.). N-Bromosuccinimide (NBS). Retrieved from [\[Link\]](#)
- YouTube. (2019). regioselectivity of radical halogenation of alkanes. Retrieved from [\[Link\]](#)
- Google Patents. (n.d.). US20160355452A1 - Method for producing (bromomethyl)cyclopropane and (bromomethyl)cyclobutane.
- Neuman, R. C. (n.d.). Chapter 11 Free Radical Substitution and Addition Reactions. Organic Chemistry. Retrieved from [\[Link\]](#)
- Master Organic Chemistry. (2011). N-BromoSuccinimide (NBS) As A Reagent In Organic Chemistry. Retrieved from [\[Link\]](#)
- Wikipedia. (n.d.). Hunsdiecker reaction. Retrieved from [\[Link\]](#)
- YouTube. (2020). 10.1 Free Radical Halogenation | Organic Chemistry. Retrieved from [\[Link\]](#)
- Chegg. (2022). 71. Select the appropriate synthetic route to convert methylcyclobutane into cyclopentene..
- Zimmermann, M., Domke, D., & Schween, M. (2021). Photobromination (SR) and Corresp. SN1 Reactions – Key Reactions for the Development and the Application of the Concept of Hyperconjugation.
- Chemistry Steps. (n.d.). Selectivity in Radical Halogenation with Practice Problems. Retrieved from [\[Link\]](#)
- Michigan State University. (n.d.). Alkane Reactivity.
- PubChem. (n.d.). 1-Bromo-1-methylcyclobutane. Retrieved from [\[Link\]](#)
- Dong, C., et al. (n.d.).
- BYJU'S. (2019). Hunsdiecker Reaction. Retrieved from [\[Link\]](#)
- YouTube. (2018). Radical Bromination: The Primary Alkane Reaction (Theory & Practice). Retrieved from [\[Link\]](#)
- Xue, F., et al. (2014). An Efficient synthesis of 1-Bromo-1-Cyanocyclopropane.

- YouTube. (2020). Selectivity in Radical Halogenation | Organic Chemistry Lessons. Retrieved from [[Link](#)]
- Vedantu. (n.d.). The major obtained in the photo catalyzed bromination class 12 chemistry CBSE. Retrieved from [[Link](#)]
- Chemistry Stack Exchange. (2016). Elimination reaction of 1-bromo-2-phenylcyclopentane. Retrieved from [[Link](#)]
- YouTube. (2021). Hunsdiecker Reaction. Retrieved from [[Link](#)]
- Mahmoud, A. R. (2025). Halogenation Reactions in Organic Synthesis: Selectivity and Mechanistic Models.
- Homework.Study.com. (n.d.). 1. Propose a mechanism for the reaction of 1-methylcyclohexanol with HBr to form.... Retrieved from [[Link](#)]
- To cite this document: BenchChem. [Technical Support Center: Methylcyclobutane Bromination Strategies]. BenchChem, [2026]. [Online PDF]. Available at: [<https://www.benchchem.com/product/b2681464/docs#technical-support-center-methylcyclobutane-bromination-strategies>]

Disclaimer & Data Validity:

The information provided in this document is for Research Use Only (RUO) and is strictly not intended for diagnostic or therapeutic procedures. While BenchChem strives to provide accurate protocols, we make no warranties, express or implied, regarding the fitness of this product for every specific experimental setup.

Technical Support: The protocols provided are for reference purposes. Unsure if this reagent suits your experiment?

Need Industrial/Bulk Grade? [Request Custom Synthesis Quote](#)

BenchChem

Our mission is to be the trusted global source of essential and advanced chemicals, empowering scientists and researchers to drive progress in science and industry.

Contact

Address: 3281 E Guasti Rd

Ontario, CA 91761, United States

Phone: (601) 213-4426

Email: info@benchchem.com

[Contact our Ph.D. Support Team for a compatibility check](#)