

Advanced Technical Guide: 1-Ethyl-4-Chloropyrazole Derivatives

Author: BenchChem Technical Support Team. **Date:** April 2026

Compound of Interest

Compound Name: (4-chloro-1-ethyl-1H-pyrazol-5-yl)methanol

CAS No.: 1310379-48-6

Cat. No.: B2674455

Get Quote

Core Scaffold Analysis, Synthetic Methodologies, and Structure-Activity Relationships[1][2]

Executive Summary: The "Privileged" Scaffold

The 1-ethyl-4-chloropyrazole moiety represents a highly specific "privileged structure" in drug discovery.[1][2] Unlike the ubiquitous 1-methyl analogs, the N1-ethyl group introduces a critical lipophilic bulk that modulates binding affinity in hydrophobic pockets, while the C4-chlorine atom serves two pivotal roles:[1][2]

- **Metabolic Blocking:** It obstructs oxidative metabolism at the C4 position, a common soft spot for cytochrome P450 enzymes.
- **Electronic Modulation:** The electron-withdrawing nature of chlorine reduces the electron density of the pyrazole ring, influencing the pKa of adjacent functional groups (e.g., carboxylic acids at C3/C5) and altering hydrogen bond donor/acceptor capabilities.

This guide details the synthesis, functionalization, and application of this scaffold in STING agonists (pharmaceuticals) and Mitochondrial Complex I inhibitors (agrochemicals).

Synthetic Architectures

Constructing the 1-ethyl-4-chloropyrazole core requires navigating regioselectivity challenges, particularly distinguishing between the C3 and C5 positions during cyclization or alkylation.[1][2]

Route A: De Novo Cyclocondensation (The Knorr Synthesis)

The most robust method for generating the core is the condensation of 1,3-dicarbonyls with ethyl hydrazine.[2]

- Mechanism: Nucleophilic attack of the hydrazine terminal nitrogen on the most electrophilic carbonyl carbon.[2]
- Regioselectivity Control:
 - Steric Bulk: If the 1,3-diketone is unsymmetrical (e.g., ethyl acetoacetate), the less hindered carbonyl is attacked by the terminal nitrogen of ethyl hydrazine.
 - Solvent Effects: Protic solvents (EtOH) favor thermodynamic control, often yielding the 5-hydroxy/5-oxo tautomers or specific isomers depending on pH.[1][2]

Route B: Post-Synthetic Functionalization

- Step 1: N-Ethylation: Alkylation of a pre-formed 4-chloropyrazole using ethyl iodide (EtI) and a base (Cs_2CO_3 or NaH).[1][2]
 - Challenge: This often yields a mixture of N1 and N2 isomers if the C3/C5 substituents are not identical.
- Step 2: C4-Chlorination: Electrophilic aromatic substitution on the 1-ethylpyrazole core.[1][2]
 - Reagents: N-Chlorosuccinimide (NCS) in DMF or SO_2Cl_2 . [1]
 - Selectivity: The C4 position is the most nucleophilic site on the pyrazole ring, ensuring high regioselectivity for halogenation.

Visualizing the Synthetic Pathways

The following diagram illustrates the two primary routes to the target scaffold, highlighting the critical decision points for regiocontrol.

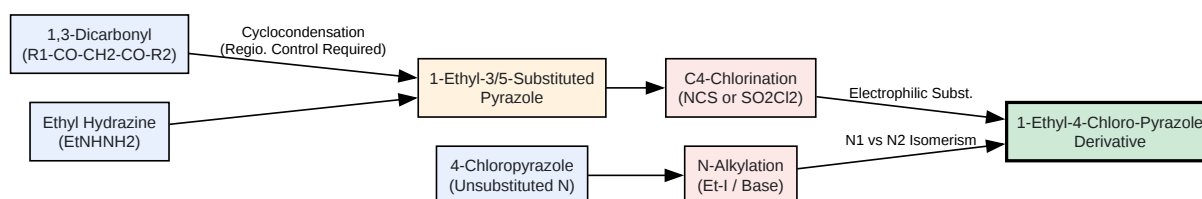

[Click to download full resolution via product page](#)

Caption: Figure 1. Convergent synthetic pathways for 1-ethyl-4-chloropyrazole derivatives. Route A (top) offers better regiocontrol for 3,5-asymmetric analogs.[1]

Detailed Experimental Protocol

Target Intermediate: 1-Ethyl-4-chloro-3-methyl-1H-pyrazole-5-carboxylic acid This specific derivative is a validated intermediate for STING agonists (e.g., WO2020042995A1).[1][2]

Step 1: Cyclization[3]

- Reagents: Ethyl acetopyruvate (1.0 eq), Ethyl hydrazine oxalate (1.1 eq), Ethanol (0.5 M).
- Procedure:
 - Dissolve ethyl acetopyruvate in absolute ethanol.
 - Add ethyl hydrazine oxalate portion-wise at 0°C.
 - Allow to warm to room temperature, then reflux for 3 hours.
 - Critical Checkpoint: Monitor by TLC/LC-MS. The major isomer should be the 1-ethyl-3-methyl-5-ester due to the reactivity of the ketone vs. ester carbonyls.[1][2]
- Workup: Concentrate in vacuo, partition between water/EtOAc, dry over MgSO₄.

Step 2: Chlorination (The "Clean" Protocol)

- Reagents: 1-Ethyl-3-methyl-pyrazole-5-carboxylate (1.0 eq), N-Chlorosuccinimide (NCS, 1.05 eq), DMF (anhydrous).
- Procedure:
 - Dissolve the pyrazole in DMF (concentration ~1.0 M).
 - Add NCS slowly at room temperature. The reaction is exothermic; maintain temp <40°C.
 - Stir for 4–6 hours.
 - Validation: ¹H NMR will show the disappearance of the C4-proton singlet (typically ~6.5 ppm).[2]
- Purification: Pour into ice water. The chlorinated product often precipitates as a solid. Filter and wash with hexanes to remove succinimide byproducts.

Step 3: Hydrolysis

- Reagents: LiOH (2.0 eq), THF/Water (1:1).
- Procedure: Stir at RT for 2 hours. Acidify to pH 3 with 1N HCl to precipitate the free acid.

Medicinal Chemistry & Applications

Pharmaceutical Application: STING Agonists

The Stimulator of Interferon Genes (STING) pathway is a prime target for cancer immunotherapy.

- Role of the Scaffold: In recent patent literature (e.g., WO2020042995A1), the 1-ethyl-4-chloro-pyrazole unit serves as a rigid linker that positions the carboxylic acid to interact with polar residues in the STING binding pocket.[1][2]
- SAR Insight: The 1-ethyl group fills a hydrophobic sub-pocket more effectively than a methyl group, improving potency (IC₅₀), while the 4-chloro atom prevents metabolic degradation, extending the half-life (

) of the drug.

Agrochemical Application: METI Acaricides

This scaffold is homologous to the "Tolfenpyrad" class of insecticides, which are Mitochondrial Electron Transport Inhibitors (METI) acting at Complex I.[3]

- Mechanism: The pyrazole ring coordinates with the ubiquinone binding site.[2]
- Lipophilicity: The N-ethyl group increases logP, enhancing cuticular penetration in pests compared to N-methyl analogs.[1][2]

Structure-Activity Relationship (SAR) Map

The following diagram summarizes the functional impact of each position on the scaffold.

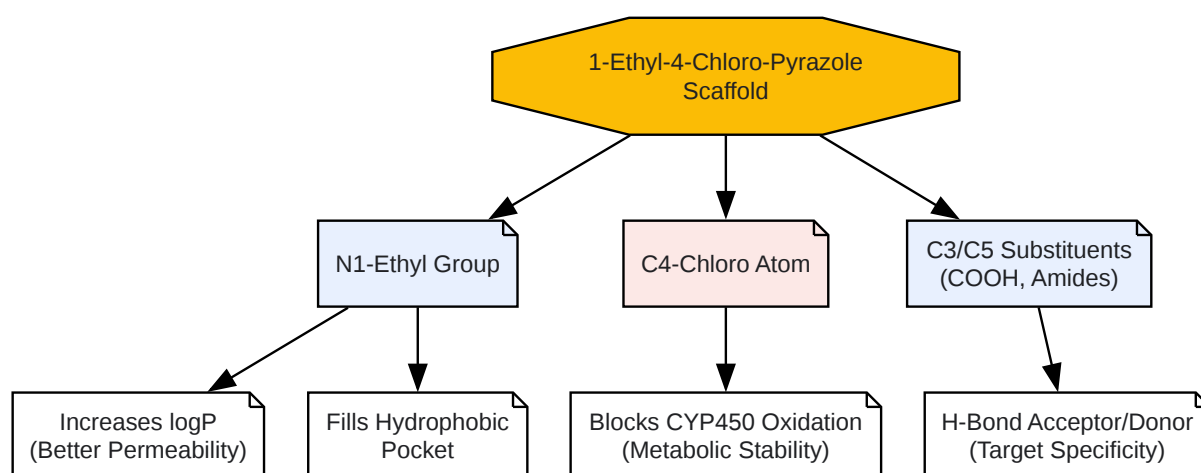

[Click to download full resolution via product page](#)

Caption: Figure 2.[1][2] SAR analysis of the 1-ethyl-4-chloropyrazole core. The N1-ethyl and C4-chloro modifications are critical for ADME properties.[1][2]

Quantitative Data Summary

Property	1-Methyl Analog	1-Ethyl Analog (Target)	Impact
LogP (Predicted)	~1.2	~1.7	Enhanced membrane permeability.[1][2]
Metabolic Stability	Low (if C4=H)	High (C4=Cl)	C4-Cl blocks oxidation; N-Et is stable.[1][2]
Steric Volume	Small	Moderate	Improved fit in larger hydrophobic pockets.
Key Application	General synthesis	STING Agonists, METI	Higher specificity for complex targets.

References

- WO2020042995A1. Novel High Activity STING Protein Agonist Compounds. World Intellectual Property Organization. (2020). [Link](#)
- BenchChem. 4-Chloro-3-ethyl-1-methyl-1H-pyrazole-5-carboxylic acid. (Accessed 2025).[4][5] [Link](#)[1]
- PubChem. 4-chloro-3-ethyl-1-methylpyrazole-5-carboxylic acid.[1][2][4][6] National Library of Medicine. [Link](#)
- Organic Chemistry Portal. Regioselective Synthesis of Pyrazoles. [Link](#)

Need Custom Synthesis?

BenchChem offers custom synthesis for rare earth carbides and specific isotopic labeling.

Email: info@benchchem.com or [Request Quote Online](#).

Sources

- 1. chemsynthesis.com [chemsynthesis.com]

- [2. CN103556174A - Synthesis method of ethyl 4-chloro-1-methyl-3-ethyl-5-pyrazolylcarboxylate - Google Patents \[patents.google.com\]](#)
- [3. pdf.benchchem.com \[pdf.benchchem.com\]](#)
- [4. 4-Chloro-3-ethyl-1-methyl-1H-pyrazole-5-carboxylic acid | C7H9ClN2O2 | CID 14770682 - PubChem \[pubchem.ncbi.nlm.nih.gov\]](#)
- [5. pdf.benchchem.com \[pdf.benchchem.com\]](#)
- [6. 4-Chloro-3-ethyl-1-methyl-1H-pyrazole-5-carboxylic Acid \[benchchem.com\]](#)
- To cite this document: BenchChem. [Advanced Technical Guide: 1-Ethyl-4-Chloropyrazole Derivatives]. BenchChem, [2026]. [Online PDF]. Available at: [\[https://www.benchchem.com/product/b2674455/docs#advanced-technical-guide-1-ethyl-4-chloropyrazole-derivatives\]](https://www.benchchem.com/product/b2674455/docs#advanced-technical-guide-1-ethyl-4-chloropyrazole-derivatives)

Disclaimer & Data Validity:

The information provided in this document is for Research Use Only (RUO) and is strictly not intended for diagnostic or therapeutic procedures. While BenchChem strives to provide accurate protocols, we make no warranties, express or implied, regarding the fitness of this product for every specific experimental setup.

Technical Support: The protocols provided are for reference purposes. Unsure if this reagent suits your experiment?

Need Industrial/Bulk Grade? [Request Custom Synthesis Quote](#)

BenchChem

Our mission is to be the trusted global source of essential and advanced chemicals, empowering scientists and researchers to drive progress in science and industry.

Contact

Address: 3281 E Guasti Rd
Ontario, CA 91761, United States
Phone: (601) 213-4426
Email: info@benchchem.com

Contact our Ph.D. Support Team for a compatibility check