

using 1-ethyl-4-methylindoline as a pharmaceutical intermediate

Author: BenchChem Technical Support Team. **Date:** April 2026

Compound of Interest

Compound Name:	1-ethyl-4-methyl-2,3-dihydro-1H-indole
CAS No.:	86911-83-3
Cat. No.:	B2673589

[Get Quote](#)

Application Note: 1-Ethyl-4-Methylindoline as a Privileged Scaffold in CNS and Oncology Drug Discovery

Executive Summary

1-Ethyl-4-methylindoline (CAS 86911-83-3) is a specialized heterocyclic intermediate increasingly utilized in the synthesis of neuroactive pharmaceuticals and targeted oncology agents. Unlike its aromatic counterpart (indole), the indoline (2,3-dihydroindole) scaffold possesses a non-planar, three-dimensional architecture that offers unique vector positioning for substituents, enhancing binding selectivity in G-Protein Coupled Receptors (GPCRs), particularly serotonergic (5-HT) and dopaminergic targets.

This guide details the strategic application, synthesis, and quality control of 1-ethyl-4-methylindoline. It addresses the critical challenge of regioselective functionalization and provides a validated protocol for its use as a core building block.

Strategic Utility in Drug Design

The "Magic Methyl" Effect at C4

In medicinal chemistry, the introduction of a methyl group at the C4 position of the indole/indoline core is a strategic modification known to induce the "Magic Methyl" effect.

- **Conformational Lock:** The C4-methyl group exerts steric pressure on substituents at the C3 position, restricting conformational freedom and potentially locking the molecule into a bioactive conformation.
- **Metabolic Blocking:** The C4 position is a common site for oxidative metabolism (hydroxylation) by Cytochrome P450 enzymes. Methylation at this site blocks this metabolic soft spot, extending the half-life () of the drug candidate.

N-Ethylation and BBB Penetration

The N-ethyl moiety serves two functions:

- **Lipophilicity Adjustment:** It increases the cLogP relative to the N-methyl or N-H analogs, facilitating passive transport across the Blood-Brain Barrier (BBB), a critical requirement for CNS drugs.
- **Electronic Modulation:** The ethyl group acts as a weak electron donor, increasing the electron density of the benzene ring, thereby activating the C5 and C7 positions for subsequent electrophilic aromatic substitutions (e.g., Vilsmeier-Haack formylation or halogenation).

Validated Synthesis Protocol

Objective: Synthesis of 1-ethyl-4-methylindoline from 4-methylindole with >98% purity.

Reaction Pathway Diagram

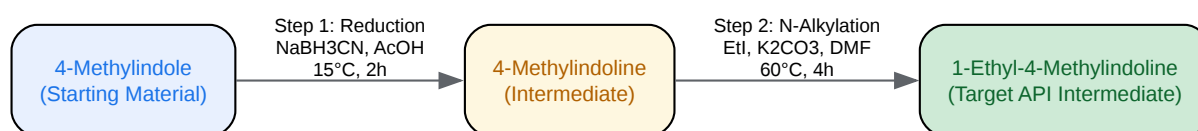

[Click to download full resolution via product page](#)

Caption: Two-step synthesis pathway converting 4-methylindole to 1-ethyl-4-methylindoline via selective reduction and N-alkylation.

Step 1: Selective Reduction of 4-Methylindole

Rationale: Direct alkylation of indole often leads to mixtures of N-alkylation and C3-alkylation. Reducing the indole to indoline first ensures the nitrogen lone pair is the exclusive nucleophile.

Materials:

- 4-Methylindole (1.0 eq)[1]
- Sodium Cyanoborohydride (NaCNBH₃) (3.0 eq)
- Glacial Acetic Acid (Solvent/Catalyst)

Procedure:

- Dissolve 4-methylindole in glacial acetic acid (10 mL/g) in a round-bottom flask under Nitrogen atmosphere.
- Cool the solution to 15°C using a water bath.
- Add NaCNBH₃ portion-wise over 30 minutes. Caution: Exothermic reaction; maintain temp <20°C to prevent over-reduction or polymerization.
- Stir at room temperature for 2 hours. Monitor by TLC (Hexane:EtOAc 8:2). The fluorescent indole spot will disappear, replaced by a non-fluorescent indoline spot (visualize with Ehrlich's reagent).
- Workup: Quench with NaOH (10% aq) at 0°C until pH > 10. Extract with Dichloromethane (DCM) (3x). Dry organic layer over MgSO₄ and concentrate.[2][3]
- Yield: Expect ~90-95% of crude 4-methylindoline.

Step 2: N-Ethylation

Rationale: Use of a weak base (K_2CO_3) in a polar aprotic solvent (DMF) favors mono-alkylation of the secondary amine.

Materials:

- 4-Methylindoline (from Step 1) (1.0 eq)
- Ethyl Iodide (EtI) (1.2 eq)
- Potassium Carbonate (K_2CO_3) (2.0 eq, anhydrous)
- DMF (Dimethylformamide) (anhydrous)[2]

Procedure:

- Dissolve 4-methylindoline in DMF (5 mL/g).
- Add K_2CO_3 and stir for 15 minutes to deprotonate any residual acidic impurities.
- Add Ethyl Iodide dropwise via syringe.
- Heat to 60°C for 4 hours. Note: Do not exceed 80°C to avoid quaternary ammonium salt formation.
- Workup: Pour mixture into ice water. Extract with Ethyl Acetate. Wash organic layer with Brine (5x) to remove DMF.
- Purification: Flash column chromatography (Silica gel, Hexane:EtOAc 95:5).
- Final Product: Pale yellow oil.

Quality Control & Specifications

For pharmaceutical applications, the impurity profile is critical.[4] The following specification sheet is recommended for incoming raw material inspection.

Parameter	Specification	Method	Rationale
Appearance	Pale yellow to colorless liquid	Visual	Oxidation leads to browning (indole formation).
Purity	≥ 98.5%	HPLC (254 nm)	High purity required for downstream coupling.
4-Methylindole	≤ 0.1%	HPLC	Residual starting material from Step 1; difficult to remove later.
Water Content	≤ 0.2%	Karl Fischer	Anhydrous conditions required for organometallic steps.
Heavy Metals	≤ 10 ppm	ICP-MS	Catalyst residue (if catalytic hydrogenation was used).

Impurity Management: The "Indole Reversion" Risk

Indolines are susceptible to oxidation back to indoles upon exposure to air and light.

- Storage: Store under Argon at 2-8°C.
- Detection: Use UV-Vis spectroscopy.^[1] Indolines have a

~250 nm and ~300 nm with low absorptivity. Indoles show strong absorption bands. The appearance of a sharp peak at ~280-290 nm with high extinction coefficient indicates oxidation.

Downstream Application: C5-Functionalization

Once synthesized, 1-ethyl-4-methylindoline is typically functionalized at the C5 position to create the full drug scaffold.

Protocol: Vilsmeier-Haack Formylation

- Reagents: POCl₃ (1.1 eq), DMF (1.2 eq).
- Mechanism: The electron-rich C5 position attacks the chloroiminium ion generated in situ.
- Outcome: Yields 1-ethyl-4-methylindoline-5-carbaldehyde.
- Utility: This aldehyde is a universal handle for reductive amination (creating CNS active amines) or Knoevenagel condensations.

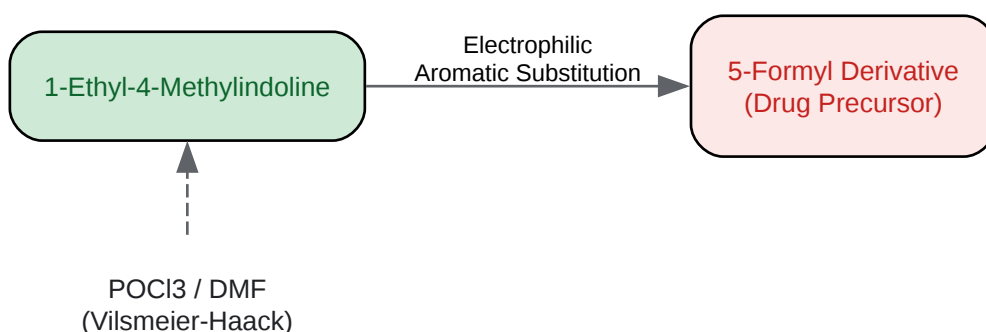

[Click to download full resolution via product page](#)

Caption: Regioselective C5-formylation of the scaffold.

References

- National Institutes of Health (NIH). (2024). Selective Iron Catalyzed Synthesis of N-Alkylated Indolines and Indoles. PubMed Central. Retrieved October 24, 2025, from [\[Link\]](#)
- Zhang, H., et al. (2020). Indole Derivatives: A Versatile Scaffold in Modern Drug Discovery. PMC. Retrieved October 24, 2025, from [\[Link\]](#)

Need Custom Synthesis?

BenchChem offers custom synthesis for rare earth carbides and specific isotopic labeling.

Email: info@benchchem.com or [Request Quote Online](#).

Sources

- [1. 1-Ethyl-4-methyl-2,3-dihydro-1h-indole \[synhet.com\]](#)
- [2. pdf.benchchem.com \[pdf.benchchem.com\]](#)
- [3. Organic Syntheses Procedure \[orgsyn.org\]](#)
- [4. molkem.com \[molkem.com\]](#)
- To cite this document: BenchChem. [using 1-ethyl-4-methylindoline as a pharmaceutical intermediate]. BenchChem, [2026]. [Online PDF]. Available at: [\[https://www.benchchem.com/product/b2673589/docs#using-1-ethyl-4-methylindoline-as-a-pharmaceutical-intermediate\]](https://www.benchchem.com/product/b2673589/docs#using-1-ethyl-4-methylindoline-as-a-pharmaceutical-intermediate)

Disclaimer & Data Validity:

The information provided in this document is for Research Use Only (RUO) and is strictly not intended for diagnostic or therapeutic procedures. While BenchChem strives to provide accurate protocols, we make no warranties, express or implied, regarding the fitness of this product for every specific experimental setup.

Technical Support: The protocols provided are for reference purposes. Unsure if this reagent suits your experiment?

Need Industrial/Bulk Grade? [Request Custom Synthesis Quote](#)

BenchChem

Our mission is to be the trusted global source of essential and advanced chemicals, empowering scientists and researchers to drive progress in science and industry.

Contact

Address: 3281 E Guasti Rd
Ontario, CA 91761, United States
Phone: (601) 213-4426
Email: info@benchchem.com

Contact our Ph.D. Support Team for a compatibility check