

Novel Diversinates™ for Pyridine Ring Functionalization

Author: BenchChem Technical Support Team. **Date:** April 2026

Compound of Interest

Compound Name: *lithium(1+)3-cyclopropylpyridine-2-sulfinate*

CAS No.: 2460748-73-4

Cat. No.: B2657105

[Get Quote](#)

A Technical Guide to Late-Stage C-H Functionalization

Executive Summary: The Renaissance of Radical Chemistry

The functionalization of pyridine rings—ubiquitous in FDA-approved pharmacophores—has historically been the "Achilles' heel" of medicinal chemistry. Traditional methods like S_EAr (Electrophilic Aromatic Substitution) fail due to the electron-deficient nature of the pyridine core, while transition-metal cross-couplings (Suzuki, Stille) require pre-functionalized handles (halides, boronates) that add synthetic steps and cost.

Diversinates™ (Zinc bis(alkanesulfinate) salts), developed by the Baran Lab and commercialized for broad adoption, represent a paradigm shift. They utilize innate C-H functionalization via a radical mechanism to append alkyl, fluoroalkyl, and heteroatom-rich moieties directly onto the pyridine core. This guide details the mechanistic underpinnings, optimized protocols, and troubleshooting frameworks for deploying Diversinates in late-stage functionalization (LSF).

The Challenge: Pyridine Inertness

Pyridine is often termed "pi-deficient." The electronegative nitrogen atom pulls electron density from the ring, making it highly resistant to electrophilic attack. Furthermore, the basic nitrogen often coordinates with transition metal catalysts (Pd, Pt), poisoning the reaction in traditional cross-coupling attempts.

The Diversinate Solution: Instead of fighting the electronics, Diversinates exploit them. By generating nucleophilic alkyl radicals, these reagents attack the electron-deficient positions (C2/C4) of the protonated pyridine ring—a modern adaptation of the Minisci reaction.

Technical Deep Dive: Mechanism of Action

The efficacy of Diversinates lies in their ability to generate radicals under mild, oxidative conditions without the need for photoredox catalysts or harsh initiators.

Mechanistic Pathway

- **Radical Generation:** The zinc sulfinate salt reacts with an oxidant (typically tert-butyl hydroperoxide, TBHP) to form a sulfonyl radical.
- **Desulfination:** The sulfonyl radical extrudes SO_2 , generating a reactive alkyl radical ().
- **Radical Addition:** The nucleophilic radical attacks the protonated pyridine (activated by TFA or acid additives) at the most electron-deficient position (C2 or C4).
- **Oxidative Rearomatization:** The resulting radical cation intermediate is oxidized and deprotonated to restore aromaticity, yielding the functionalized product.

Mechanistic Visualization

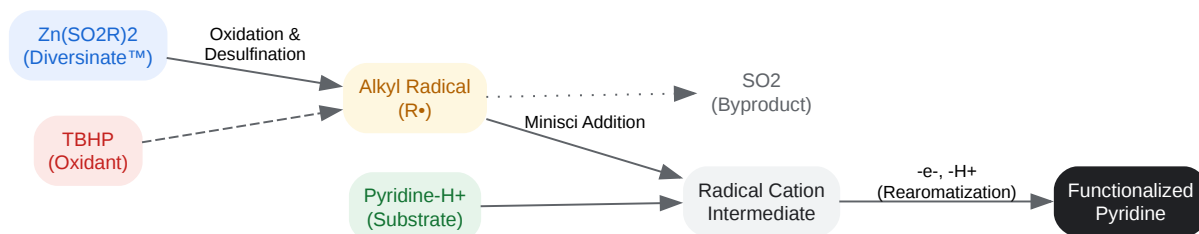

[Click to download full resolution via product page](#)

Figure 1: Mechanistic pathway of Zinc Sulfinate-mediated C-H functionalization.

Experimental Protocol: Trifluoromethylation of Pyridine

Standard Operating Procedure (SOP) for installing a $-CF_3$ group using Zinc Trifluoromethanesulfinate (TFZ).

Reagents & Materials

Reagent	Equivalents (eq)	Role
Substrate (Pyridine)	1.0	Target Molecule
Diversinate™ (TFZ)	3.0	Radical Source
TBHP (70% aq.)	3.0 - 5.0	Oxidant
TFA (Trifluoroacetic acid)	1.0	Activator (Proton source)
DMSO/Water (2:1)	Solvent	Reaction Medium

Step-by-Step Methodology

- Setup: To a vial equipped with a magnetic stir bar, add the Pyridine substrate (0.5 mmol, 1.0 eq) and Diversinate™ TFZ (1.5 mmol, 3.0 eq).
- Solvent Addition: Add DMSO (1.5 mL) and Water (0.75 mL). Note: Biphasic systems (DCM/H₂O) are also effective for lipophilic substrates.

- Activation: Add TFA (0.5 mmol, 1.0 eq) dropwise. Critical: Protonation lowers the LUMO of the pyridine, accelerating radical attack.
- Initiation: Cool the mixture to 0°C (optional, to control exotherm) and add TBHP (70% aq, 5.0 eq) dropwise.
- Reaction: Allow the mixture to warm to room temperature (or heat to 50°C for sluggish substrates) and stir vigorously for 12–24 hours. Open-flask conditions are generally tolerated, but sealed vials prevent solvent evaporation.
- Workup:
 - Quench with sat. NaHCO₃ (to neutralize TFA and solubilize Zn salts).
 - Extract with EtOAc (3x).
 - Wash combined organics with brine, dry over Na₂SO₄, and concentrate.
- Purification: Flash column chromatography (Silica gel).

Workflow Diagram

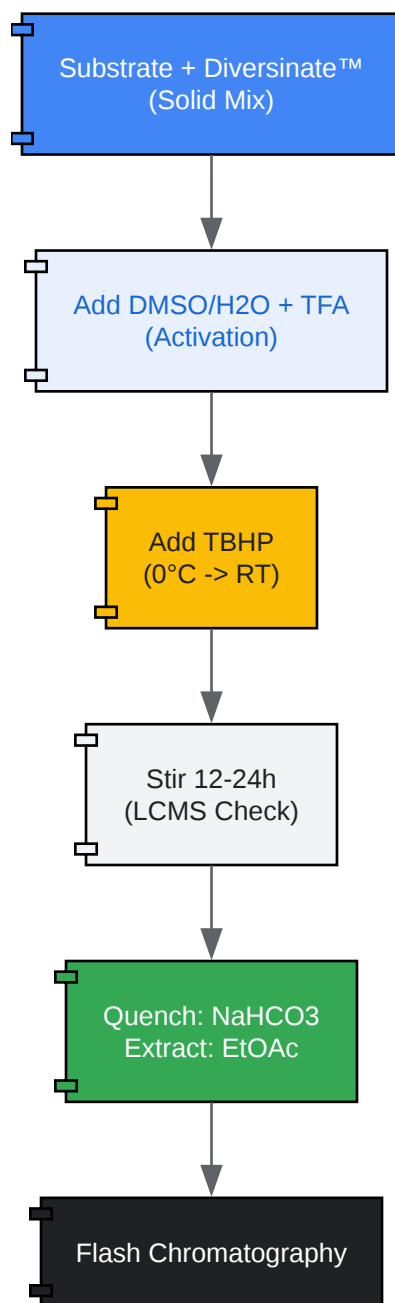

[Click to download full resolution via product page](#)

Figure 2: Operational workflow for Diversinate-mediated functionalization.

Scope & Performance Data

Diversinates are particularly powerful for "Late-Stage Functionalization" (LSF), allowing chemists to modify complex drug scaffolds directly.^{[1][2]}

Functional Group Tolerance

Substituent (R)	Reagent	Selectivity (Pyridine)	Yield (Avg)	Notes
Trifluoromethyl (-CF ₃)	Zn(SO ₂ CF ₃) ₂	C2 > C4	50-80%	Highly electron-withdrawing; useful for metabolic stability.
Difluoromethyl (-CF ₂ H)	Zn(SO ₂ CF ₂ H) ₂	C2 > C4	40-70%	Lipophilic H-bond donor.
Isopropyl (-iPr)	Zn(SO ₂ iPr) ₂	C2/C4 Mix	40-60%	Adds steric bulk; Minisci-selective.
Difluoroethyl (-CF ₂ CH ₃)	Zn(SO ₂ CF ₂ Et) ₂	C2	45-65%	Bioisostere for ethyl/carbonyl.

Case Study: Functionalization of Papaverine

In a comparative study utilizing Baran Diversinates™, the alkaloid Papaverine (containing an isoquinoline core, electronically similar to pyridine) was functionalized.

- Outcome: Successful installation of alkyl and fluoroalkyl groups at the C1 position.
- Significance: Demonstrated LSF on a biologically active scaffold without protecting groups, reducing synthetic steps from >5 (de novo) to 1 (Diversinate).

Troubleshooting & Optimization

Even with robust reagents, heterocycle functionalization can be nuanced.^[3]

- Problem: Low Conversion.
 - Root Cause:^{[4][5][6]} Poor radical generation or catalyst poisoning.
 - Fix: Increase TBHP equivalents (up to 10 eq) or temperature (50-60°C). Ensure efficient stirring (biphasic mixtures require high rpm).

- Problem: Regioselectivity Issues.
 - Root Cause:[4][5][6] Competitive sites on the ring.
 - Fix: Vary the solvent. DMSO promotes mono-functionalization. Using DCM/Water can sometimes alter selectivity due to "phase-transfer" effects of the radical species.
- Problem: Decomposition.
 - Root Cause:[4][5][6] Over-oxidation.
 - Fix: Add TBHP slowly via syringe pump over 2 hours.

References

- Fujiwara, Y., et al. "Practical C–H Functionalization of Quinones with Boronic Acids." J. Am. Chem. Soc., 2011.[2] [Link](#)
- Fujiwara, Y., et al. "A New Reagent for Direct Difluoromethylation." [2] J. Am. Chem. Soc., 2012. [Link](#)
- Gui, J., et al. "Practical Olefin Hydroamination with Nitroarenes." Science, 2014. (Context on Baran Radical Chemistry). [Link](#)
- O'Hara, F., et al. "A Simple, Scalable, and Highly Tunable Reagent for the Direct Difluoromethylation of Heterocycles." Nature Protocols, 2013. [Link](#)
- Sigma-Aldrich. "Baran Diversinates™ User Guide." Merck KGaA. [Link](#)

Need Custom Synthesis?

BenchChem offers custom synthesis for rare earth carbides and specific isotopic labeling.

Email: info@benchchem.com or [Request Quote Online](#).

Sources

- [1. researchgate.net](https://www.researchgate.net) [[researchgate.net](https://www.researchgate.net)]

- [2. mdpi.com \[mdpi.com\]](#)
- [3. researchgate.net \[researchgate.net\]](#)
- [4. baranlab.org \[baranlab.org\]](#)
- [5. kindai.repo.nii.ac.jp \[kindai.repo.nii.ac.jp\]](#)
- [6. analytik.news \[analytik.news\]](#)
- To cite this document: BenchChem. [Novel Diversinates™ for Pyridine Ring Functionalization]. BenchChem, [2026]. [Online PDF]. Available at: [\[https://www.benchchem.com/product/b2657105/docs#novel-diversinates-for-pyridine-ring-functionalization\]](https://www.benchchem.com/product/b2657105/docs#novel-diversinates-for-pyridine-ring-functionalization)

Disclaimer & Data Validity:

The information provided in this document is for Research Use Only (RUO) and is strictly not intended for diagnostic or therapeutic procedures. While BenchChem strives to provide accurate protocols, we make no warranties, express or implied, regarding the fitness of this product for every specific experimental setup.

Technical Support: The protocols provided are for reference purposes. Unsure if this reagent suits your experiment?

Need Industrial/Bulk Grade? [Request Custom Synthesis Quote](#)

BenchChem

Our mission is to be the trusted global source of essential and advanced chemicals, empowering scientists and researchers to drive progress in science and industry.

Contact

Address: 3281 E Guasti Rd

Ontario, CA 91761, United States

Phone: (601) 213-4426

Email: info@benchchem.com

Contact our Ph.D. Support Team for a compatibility check