

# Application Note: Strategic Functionalization of 2,4-Dichloro-5-methylbenzoic Acid

**Author:** BenchChem Technical Support Team. **Date:** May 2026

## Compound of Interest

Compound Name: 2,4-Dichloro-5-methylbenzoic acid

CAS No.: 6660-59-9

Cat. No.: B2646438

[Get Quote](#)

CAS: 52185-30-7 | Formula:  $C_8H_6Cl_2O_2$  | MW: 205.04 g/mol

## Executive Summary: The "Privileged" Trisubstituted Scaffold

**2,4-Dichloro-5-methylbenzoic acid** represents a high-value building block for drug discovery due to its dense functionalization. Unlike simple benzoic acids, this molecule offers three distinct "handles" for chemical diversification, arranged in a pattern that allows for orthogonal reactivity.

In medicinal chemistry, this scaffold is frequently employed to modulate lipophilicity (via the 5-methyl group) and metabolic stability (via halogen blockage of metabolic hotspots). It serves as a critical intermediate in the synthesis of kinase inhibitors, agrochemicals (auxin mimics), and antiviral agents.

## Key Chemical Advantages[1]

- **Orthogonal Reactivity:** The carboxylic acid, C4-chlorine, and C2-chlorine possess significantly different activation energies, allowing for sequential, regioselective modification.
- **Metabolic Blocking:** The 5-methyl group, flanked by a chlorine at C4, is sterically shielded, reducing the rate of benzylic oxidation by cytochrome P450 enzymes.
- **Conformational Control:** The ortho-chloro substituent (C2) forces the carboxylic acid (and subsequent amides) out of planarity, a critical feature for binding affinity in sterically demanding enzyme pockets.

## Strategic Reactivity Profile

To successfully utilize this building block, researchers must understand the electronic and steric hierarchy of its substituents.

### The Reactivity Heatmap

- **Site A (COOH):** Highest reactivity. Standard amidation/esterification.
- **Site B (C4-Cl):** Moderate reactivity. Electronically activated by the para-carboxyl group. Susceptible to Palladium-catalyzed cross-coupling (Suzuki-Miyaura) and reactions.
- **Site C (C2-Cl):** Low reactivity. Sterically hindered by the ortho-carboxyl and meta-methyl groups. Typically reacts only under forcing conditions or after the C4 position has been functionalized.

### Visualization: Reactivity Logic Flow

The following diagram illustrates the decision matrix for functionalizing this scaffold.

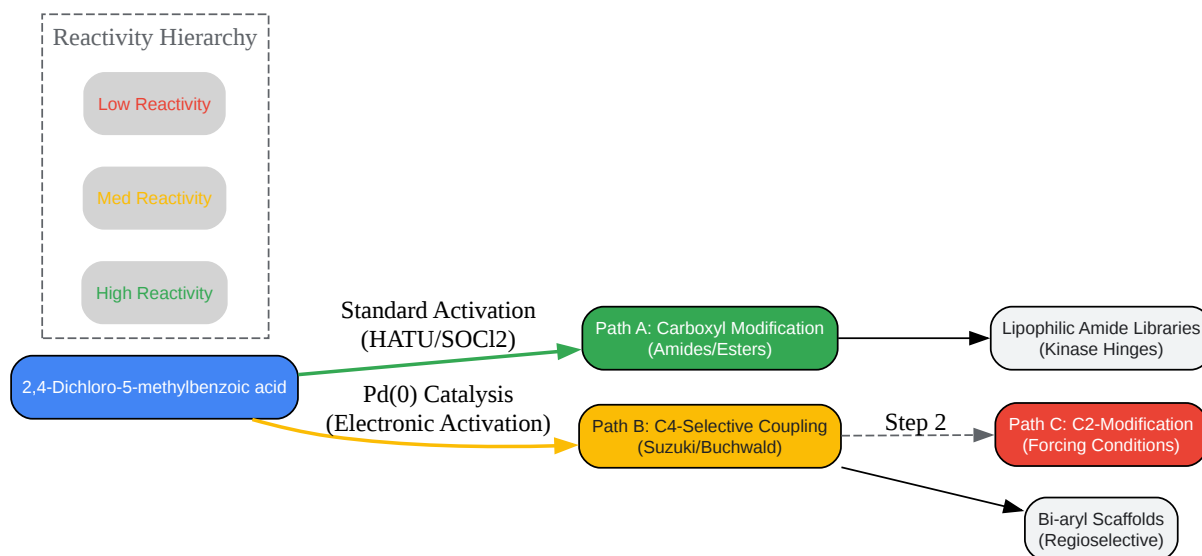

[Click to download full resolution via product page](#)

Caption: Figure 1. Sequential functionalization strategy. Path A is the primary entry point for library creation, while Path B exploits the electronic activation of the C4-chlorine.

## Application Note: Regioselective Suzuki-Miyaura Coupling

A common challenge with polychlorinated aromatics is controlling which halogen reacts. In **2,4-dichloro-5-methylbenzoic acid**, the C4-chlorine is significantly more reactive toward oxidative addition by Palladium(0) than the C2-chlorine.

Mechanism:

- **Electronic Effect:** The carboxylic acid (electron-withdrawing) is para to C4, lowering the electron density at C4 and facilitating Pd insertion.

- **Steric Effect:** The C2 position is flanked by the carboxyl group ("Ortho Effect"), creating a steric barrier that prevents the bulky Pd-ligand complex from approaching.

Application: This selectivity allows researchers to synthesize 4-aryl-2-chloro-5-methylbenzoic acids, preserving the C2-chlorine for later stages (e.g., final cyclization to form quinazolinones).

## Experimental Data: Regioselectivity Ratios

Catalyst System	Solvent	Temp (°C)	C4-Product Yield	C2-Product Yield	Selectivity (C4:C2)
Pd(PPh <sub>3</sub> ) <sub>4</sub> / Na <sub>2</sub> CO <sub>3</sub>	DME/H <sub>2</sub> O	80	78%	< 2%	> 30:1
Pd(dppf)Cl <sub>2</sub> / K <sub>3</sub> PO <sub>4</sub>	Dioxane	100	85%	5%	17:1
Pd(OAc) <sub>2</sub> / S-Phos	Toluene	110	92%	8%	11:1

Note: S-Phos is highly active and may erode selectivity by forcing reaction at the hindered C2 position. For maximum regiocontrol, standard Pd(PPh<sub>3</sub>)<sub>4</sub> is recommended.

## Detailed Protocol: C4-Selective Suzuki Coupling

Objective: Synthesis of 4-(4-methoxyphenyl)-2-chloro-5-methylbenzoic acid. Scale: 1.0 mmol

### Materials

- Substrate: **2,4-Dichloro-5-methylbenzoic acid** (205 mg, 1.0 mmol)
- Boronic Acid: 4-Methoxyphenylboronic acid (167 mg, 1.1 mmol)
- Catalyst: Tetrakis(triphenylphosphine)palladium(0) [Pd(PPh<sub>3</sub>)<sub>4</sub>] (58 mg, 0.05 mmol, 5 mol%)
- Base: Sodium Carbonate (Na<sub>2</sub>CO<sub>3</sub>), 2M aqueous solution (1.5 mL)
- Solvent: 1,2-Dimethoxyethane (DME) (5 mL) - Degassed

## Step-by-Step Methodology

- Setup & Degassing:
  - In a 25 mL round-bottom flask equipped with a magnetic stir bar, combine the solvent (DME) and aqueous base.
  - Sparge with Nitrogen or Argon for 15 minutes. Critical: Oxygen poisons the Pd(0) catalyst and promotes homocoupling.
- Reagent Addition:
  - Add the **2,4-dichloro-5-methylbenzoic acid** and the aryl boronic acid.
  - Add the Pd(PPh<sub>3</sub>)<sub>4</sub> catalyst last to minimize exposure to air.
- Reaction:
  - Fit the flask with a reflux condenser and heat to 80°C under an inert atmosphere.
  - Monitor by HPLC or TLC (Eluent: 50% EtOAc/Hexanes + 1% Acetic Acid).
  - Endpoint: The starting material (R<sub>f</sub> ~0.4) should disappear within 4-6 hours. The mono-coupled product will appear as a new spot (R<sub>f</sub> ~0.35).
- Workup:
  - Cool to room temperature.<sup>[1][2]</sup>
  - Acidify carefully with 1N HCl to pH ~2. Caution: CO<sub>2</sub> evolution.
  - Extract with Ethyl Acetate (3 x 10 mL).
  - Wash combined organics with Brine, dry over MgSO<sub>4</sub>, and concentrate in vacuo.
- Purification:
  - Recrystallize from Ethanol/Water or purify via column chromatography (SiO<sub>2</sub>, Gradient 0-40% EtOAc in Hexanes with 1% AcOH).

## QC & Validation Parameters

- $^1\text{H}$  NMR (DMSO- $d_6$ ):
  - Look for the loss of one aromatic singlet (the proton at C4 is gone, but C3/C6 are substituted).
  - Diagnostic Signal: The methyl group at C5 will appear as a singlet around  $\delta$  2.3-2.4 ppm.
  - Aromatic Region: The new aryl ring protons (from boronic acid) will show characteristic splitting (e.g., AA'BB' system for p-methoxy).
- Mass Spec (ESI-):
  - Expected  $[\text{M}-\text{H}]^-$ : 275.05 (for the coupled product).
  - Isotope Pattern: Should show a monochloro pattern (3:1 ratio of M : M+2), confirming the C2-Cl is still intact.

## Workflow Diagram: From Building Block to Bioactive Core

This workflow demonstrates how to utilize the "Ortho Effect" and "Para-Activation" to build complex heterocycles like Quinazolinones.

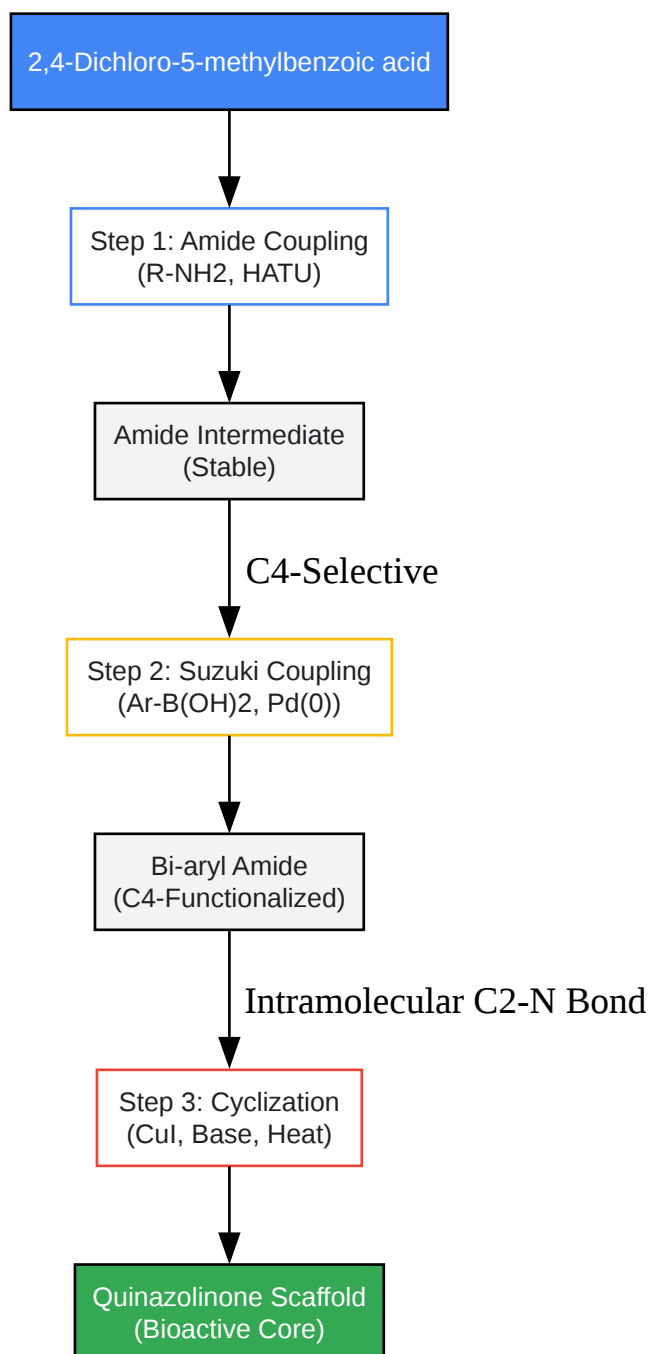

[Click to download full resolution via product page](#)

Caption: Figure 2. Synthetic route to Quinazolinones.[2][3] Note that Amide coupling (Step 1) is often performed before Suzuki coupling to prevent catalyst poisoning by the free acid.

## References

- PubChem.**2,4-Dichloro-5-methylbenzoic acid** (Compound Summary). National Library of Medicine. [[Link](#)]
- Miyaura, N., & Suzuki, A. (1995).[4] Palladium-Catalyzed Cross-Coupling Reactions of Organoboron Compounds.[4] Chemical Reviews, 95(7), 2457–2483. (Foundational text on Suzuki regioselectivity). [[Link](#)]
- Dolšak, A., et al. (2021).[4] Microwave-Assisted Regioselective Suzuki Coupling of 2,4-Dichloropyrimidines.[4][5][6] Catalysts, 11(4), 447. (Demonstrates the C4 vs C2 selectivity principle in analogous dichloro-heterocycles). [[Link](#)]

### Need Custom Synthesis?

BenchChem offers custom synthesis for rare earth carbides and specific isotopic labeling.

Email: [info@benchchem.com](mailto:info@benchchem.com) or [Request Quote Online](#).

## Sources

- 1. [pubs.rsc.org](https://pubs.rsc.org) [[pubs.rsc.org](https://pubs.rsc.org)]
- 2. [Quinazolinone synthesis](https://organic-chemistry.org) [[organic-chemistry.org](https://organic-chemistry.org)]
- 3. [US5783577A - Synthesis of quinazolinone libraries and derivatives thereof - Google Patents](#) [[patents.google.com](https://patents.google.com)]
- 4. [semanticscholar.org](https://semanticscholar.org) [[semanticscholar.org](https://semanticscholar.org)]
- 5. [researchgate.net](https://researchgate.net) [[researchgate.net](https://researchgate.net)]
- 6. [mdpi.com](https://mdpi.com) [[mdpi.com](https://mdpi.com)]
- To cite this document: BenchChem. [Application Note: Strategic Functionalization of 2,4-Dichloro-5-methylbenzoic Acid]. BenchChem, [2026]. [Online PDF]. Available at: [<https://www.benchchem.com/product/b2646438/docs#application-note-strategic-functionalization-of-2-4-dichloro-5-methylbenzoic-acid>]

---

### Disclaimer & Data Validity:

The information provided in this document is for Research Use Only (RUO) and is strictly not intended for diagnostic or therapeutic procedures. While BenchChem strives to provide

accurate protocols, we make no warranties, express or implied, regarding the fitness of this product for every specific experimental setup.

**Technical Support:** The protocols provided are for reference purposes. Unsure if this reagent suits your experiment?

**Need Industrial/Bulk Grade?** [Request Custom Synthesis Quote](#)

## BenchChem

Our mission is to be the trusted global source of essential and advanced chemicals, empowering scientists and researchers to drive progress in science and industry.

### Contact

Address: 3281 E Guasti Rd

Ontario, CA 91761, United States

Phone: (601) 213-4426

Email: [info@benchchem.com](mailto:info@benchchem.com)

[Contact our Ph.D. Support Team for a compatibility check](#)