

Spectral Fingerprints: A Comparative Guide to UV-Vis Absorption of Polysubstituted Benzoates

Author: BenchChem Technical Support Team. **Date:** May 2026

Compound of Interest

Compound Name: *Methyl 3-(hydroxymethyl)-2-methoxybenzoate*

CAS No.: *1427363-87-8*

Cat. No.: *B2637643*

[Get Quote](#)

Executive Summary

Polysubstituted benzoates—ranging from simple preservatives like methyl paraben to complex antioxidants like gallic acid—are ubiquitous in pharmaceutical formulations. Their UV-Vis absorption profiles are not merely identification tags; they are direct readouts of the electronic environment of the benzene ring.

This guide moves beyond basic spectral libraries to explain why spectra shift, providing a comparative analysis of mono-, di-, and tri-substituted derivatives. It equips researchers with the mechanistic insight to predict spectral behavior, optimize detection methods (HPLC-UV), and troubleshoot formulation stability issues (e.g., pH-induced shifts).

Mechanistic Foundation: The Electronic Stage

To interpret the spectra of polysubstituted benzoates, one must understand the interplay between the aromatic

-system and its substituents.

Electronic Transitions

The benzene ring exhibits three primary absorption bands originating from transitions:

- E1 Band (184 nm): High energy, usually obscured by solvent cutoff.
- E2 Band (Primary, ~203 nm): Strong intensity ().
- B Band (Secondary, ~254 nm): Forbidden transition, weak intensity (), characterized by fine structure in non-polar solvents.

Substituent Effects (Auxochromes & Chromophores)

Substituents alter these bands via Mesomeric (Resonance) and Inductive effects.

- Electron Donating Groups (EDGs): Substituents like , , and possess lone pairs that interact with the ring's π -system (conjugation). This raises the energy of the HOMO (Highest Occupied Molecular Orbital) more than the LUMO, narrowing the energy gap ().
 - Result: Bathochromic Shift (Red Shift) and Hyperchromic Effect (increased intensity).
- Electron Withdrawing Groups (EWGs): The carboxyl group () withdraws electrons, extending the conjugation system.
 - Result: Significant Red Shift of the E2 band (often merging with the B band).

Visualization: Electronic Interaction Pathway

The following diagram illustrates how substituents modify the benzene spectral baseline.

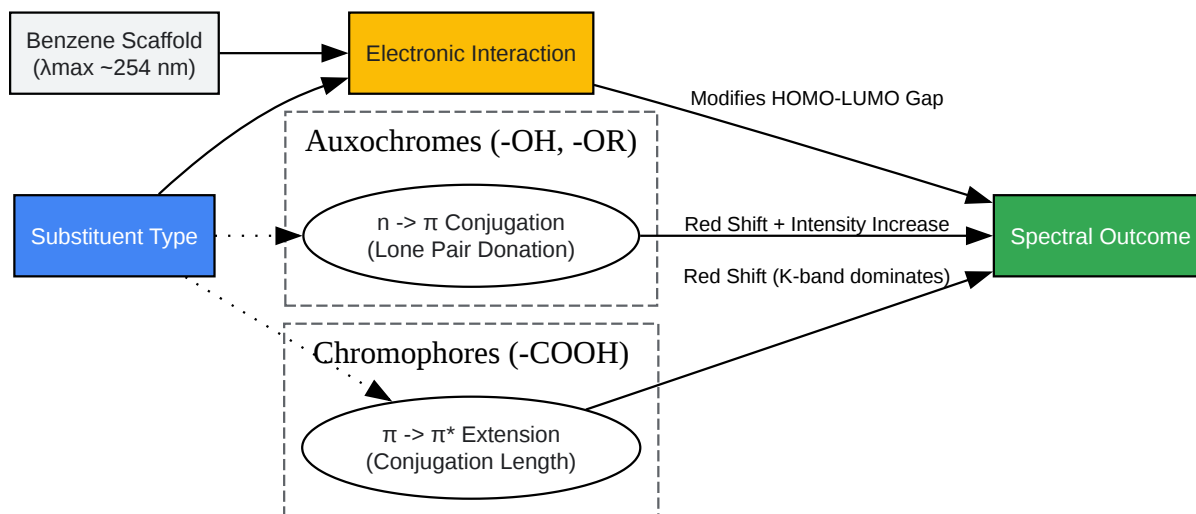

[Click to download full resolution via product page](#)

Figure 1: Causal pathway of substituent effects on the benzene chromophore.

Comparative Analysis: Mono- vs. Poly-substitution

The following data synthesizes experimental values for key benzoate derivatives. Note how increasing oxygenation (adding -OH/-OR groups) progressively shifts the absorption maximum.

Spectral Data Summary[1]

Compound	Structure	Substituents	(nm)*	(L/mol-cm)	Key Feature
Benzoic Acid	Phenyl-COOH	None (on ring)	230, 273	~10,000 (230nm)	Baseline reference. Distinct E2 and B bands.
Methyl Paraben	4-Hydroxybenzoate	4-OH	256	~16,000	Strong bathochromic shift due to para-OH resonance.
Salicylic Acid	2-Hydroxybenzoate	2-OH	236, 296	~3,500 (296nm)	Intramolecular H-bonding stabilizes excited state, causing large red shift.
Vanillic Acid	4-Hydroxy-3-methoxy	3-OCH3, 4-OH	260, 292	~14,000	Additive effect of methoxy auxochrome.
Gallic Acid	3,4,5-Trihydroxy	3,4,5-OH	215, 270	~9,500 (270nm)	Broad absorption due to multiple resonance contributors.
Syringic Acid	4-Hydroxy-3,5-dimethoxy	3,5-OCH3, 4-OH	275	~12,000	Steric crowding and heavy electron donation maximize red shift.

*Data represents typical values in Methanol/Ethanol. Aqueous values may vary by 2-5 nm.

Critical Comparisons

Case A: The "Ortho" Effect (Methyl Paraben vs. Salicylic Acid)

While Methyl Paraben (para-substituted) absorbs at 256 nm, Salicylic Acid (ortho-substituted) shows a distinct band near 296 nm.

- Mechanism: The ortho-hydroxyl group forms an intramolecular hydrogen bond with the carbonyl oxygen of the benzoate. This "chelating" effect stabilizes the molecule in a planar configuration and significantly lowers the energy of the excited state, leading to a dramatic red shift compared to the para isomer.

Case B: The "Additive" Effect (Vanillic vs. Syringic Acid)

Comparing Vanillic (di-substituted) to Syringic (tri-substituted) acid reveals the additivity of auxochromes.

- Adding a second methoxy group at position 5 (Syringic) pushes the absorption from ~260 nm (Vanillic) to ~275 nm. The increased electron density in the ring facilitates the transition.

Environmental Factors: Solvent & pH[2]

Spectral data is meaningless without context. The environment of the molecule can alter the spectrum as much as the substituents themselves.

pH-Dependent Ionization

Polysubstituted benzoates behave as weak acids. The ionization state (protonated vs. deprotonated) radically alters the resonance.

- Phenolic Deprotonation (pH > pKa ~8-10):
 - Conversion of

to

creates a powerful electron donor.

- Result: Massive Bathochromic Shift (+10 to +20 nm) and Hyperchromic effect.
- Application: This shift is often used in differential UV spectroscopy to quantify phenols in complex matrices.
- Carboxyl Deprotonation ($\text{pH} > \text{pKa} \sim 4$):
 - Conversion of
 - to
 - creates a symmetrical resonance structure that is less effective at conjugating with the ring than the protonated carbonyl.
 - Result: Slight Hypsochromic (Blue) Shift and loss of fine structure.

Solvatochromism

- Polar Protic Solvents (Water, Methanol): Stabilize the polar excited state of transitions, leading to a Red Shift. However, they can Blue Shift bands by stabilizing the non-bonding ground state via H-bonding.
- Non-Polar Solvents (Hexane): Preserve vibrational fine structure (B-band) which is often smoothed out in polar solvents.

Experimental Protocol: Validated Spectral Acquisition

To ensure reproducibility (Trustworthiness), follow this self-validating protocol.

Workflow

The following Graphviz diagram outlines the critical decision points in the experimental workflow.

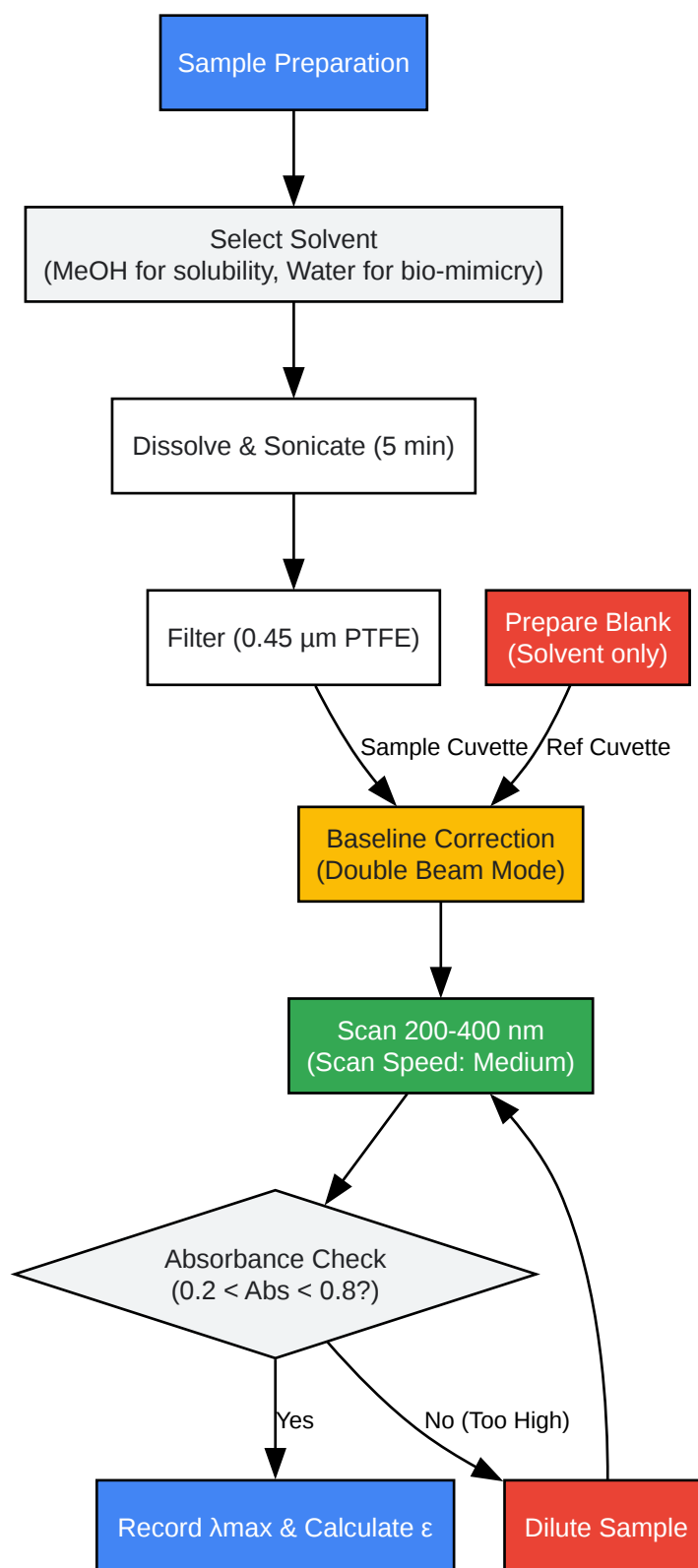

[Click to download full resolution via product page](#)

Figure 2: Step-by-step workflow for accurate UV-Vis acquisition of benzoate derivatives.

Detailed Methodology

- Stock Solution: Prepare a 1.0 mg/mL stock in Methanol (HPLC grade). Most polysubstituted benzoates have limited water solubility in the protonated form.
- Working Standard: Dilute stock to ~10 µg/mL.
 - Validation Step: The absorbance at

must fall between 0.2 and 0.8 AU to adhere to the Beer-Lambert linear range.
- Blanking: Use the exact solvent batch used for dilution. Mismatched blanks cause baseline drift below 220 nm.
- Scanning: Scan from 200 to 400 nm.
 - Note: If using a glass cuvette, data <300 nm is invalid. Quartz cuvettes are mandatory.

References

- NIST Chemistry WebBook. UV/Visible Spectra of Benzoic Acid and Derivatives. National Institute of Standards and Technology. [1] [\[Link\]](#)[1]
- Karimova, N. V., et al. (2020). Absorption Spectra of Benzoic Acid in Water at Different pH and in the Presence of Salts. Physical Chemistry Chemical Physics. [\[Link\]](#)
- SIELC Technologies. UV-Vis Spectrum of Methylparaben and Gallic Acid. [\[Link\]](#)
- Friedman, M., et al. Substituent Effects on the UV Spectra of Benzoic Acid Derivatives. Journal of Chemical Education.

Need Custom Synthesis?

BenchChem offers custom synthesis for rare earth carbides and specific isotopic labeling.

Email: info@benchchem.com or [Request Quote Online](#).

Sources

- 1. Vanillic acid [webbook.nist.gov]
- To cite this document: BenchChem. [Spectral Fingerprints: A Comparative Guide to UV-Vis Absorption of Polysubstituted Benzoates]. BenchChem, [2026]. [Online PDF]. Available at: [<https://www.benchchem.com/product/b2637643/docs#spectral-fingerprints-a-comparative-guide-to-uv-vis-absorption-of-polysubstituted-benzoates>]

Disclaimer & Data Validity:

The information provided in this document is for Research Use Only (RUO) and is strictly not intended for diagnostic or therapeutic procedures. While BenchChem strives to provide accurate protocols, we make no warranties, express or implied, regarding the fitness of this product for every specific experimental setup.

Technical Support: The protocols provided are for reference purposes. Unsure if this reagent suits your experiment?

Need Industrial/Bulk Grade? [Request Custom Synthesis Quote](#)

BenchChem

Our mission is to be the trusted global source of essential and advanced chemicals, empowering scientists and researchers to drive progress in science and industry.

Contact

Address: 3281 E Guasti Rd
Ontario, CA 91761, United States
Phone: (601) 213-4426
Email: info@benchchem.com

[Contact our Ph.D. Support Team for a compatibility check](#)