

Application Notes and Protocols: Assessing Apoptosis in Cells Treated with CWHM-1008

Author: BenchChem Technical Support Team. **Date:** April 2026

Compound of Interest

Compound Name:	CWHM-1008
CAS No.:	2362539-97-5
Cat. No.:	B2630313

[Get Quote](#)

Audience: Researchers, scientists, and drug development professionals.

Introduction

CWHM-1008, a novel antimalarial agent, has demonstrated promising anti-cancer properties by inducing apoptosis in cancer cells.[1] Understanding the mechanisms by which **CWHM-1008** induces programmed cell death is crucial for its development as a potential therapeutic. These application notes provide detailed protocols for assessing apoptosis in cells treated with **CWHM-1008**, focusing on key methods to detect the hallmark features of this process. The provided methodologies will guide researchers in quantifying apoptotic events and elucidating the underlying signaling pathways.

Mechanism of Action: CWHM-1008 Induced Apoptosis

Studies have shown that **CWHM-1008** induces apoptosis in lung adenocarcinoma cells by inhibiting the Akt/mTOR signaling pathway.[1] This pathway is a critical regulator of cell survival, proliferation, and growth. By blocking this axis, **CWHM-1008** initiates a cascade of events

leading to programmed cell death. The following diagram illustrates the proposed signaling pathway.

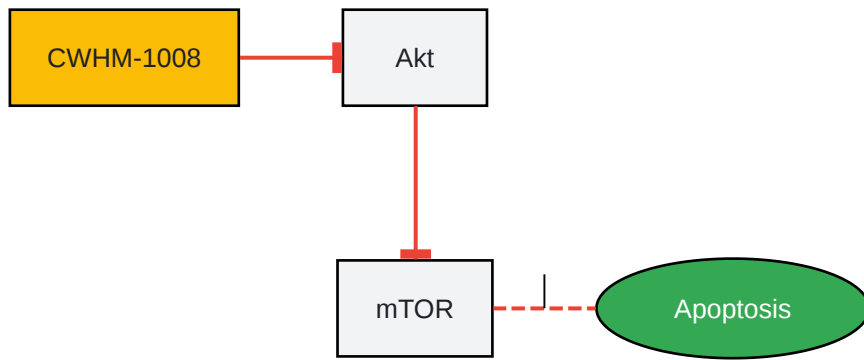

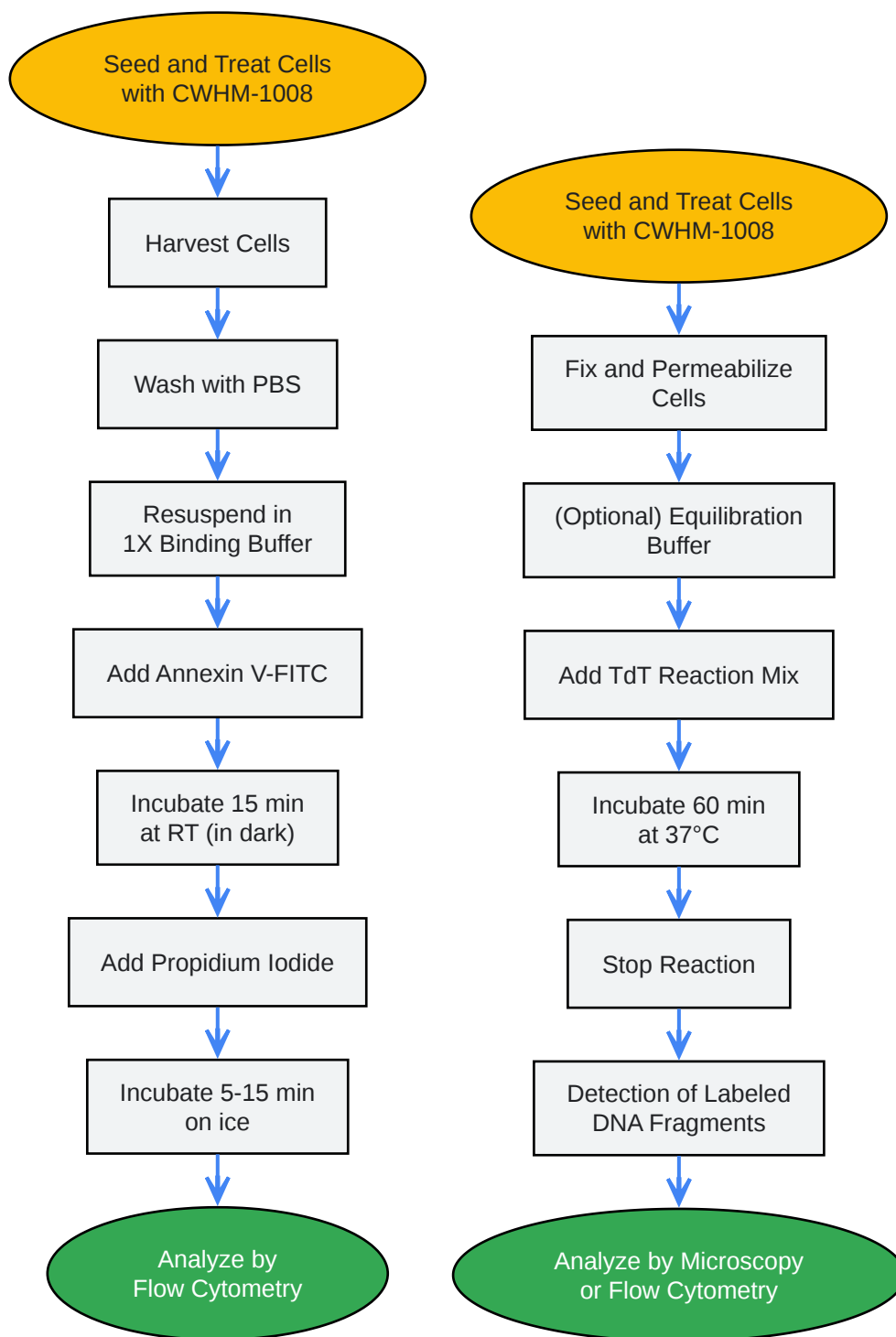

[Click to download full resolution via product page](#)

Need Custom Synthesis?

BenchChem offers custom synthesis for rare earth carbides and specific isotopic labeling.

Email: info@benchchem.com or [Request Quote Online](#).

References

- [1. CWHM-1008 Induces Apoptosis and Protective Autophagy through the Akt/mTOR Axis in LUAD Cells - PMC \[pmc.ncbi.nlm.nih.gov\]](#)
- To cite this document: BenchChem. [Application Notes and Protocols: Assessing Apoptosis in Cells Treated with CWHM-1008]. BenchChem, [2026]. [Online PDF]. Available at: [<https://www.benchchem.com/product/b2630313/docs#application-notes-and-protocols-assessing-apoptosis-in-cells-treated-with-cwhm-1008>]

Disclaimer & Data Validity:

The information provided in this document is for Research Use Only (RUO) and is strictly not intended for diagnostic or therapeutic procedures. While BenchChem strives to provide accurate protocols, we make no warranties, express or implied, regarding the fitness of this product for every specific experimental setup.

Technical Support: The protocols provided are for reference purposes. Unsure if this reagent suits your experiment?

Need Industrial/Bulk Grade? [Request Custom Synthesis Quote](#)

BenchChem

Our mission is to be the trusted global source of essential and advanced chemicals, empowering scientists and researchers to drive progress in science and industry.

Contact

Address: 3281 E Guasti Rd
Ontario, CA 91761, United States
Phone: (601) 213-4426
Email: info@benchchem.com

[Contact our Ph.D. Support Team for a compatibility check](#)

