

Cross-Validation of Spectroscopic Data: A Comparative Guide for Researchers

Author: BenchChem Technical Support Team. **Date:** May 2026

Compound of Interest

Compound Name: *Topps*
CAS No.: *45875-67-0*
Cat. No.: *B2623350*

[Get Quote](#)

In the realm of scientific research and drug development, the accuracy and reliability of experimental data are paramount. Spectroscopic techniques are powerful tools for elucidating molecular structures and quantifying substances, but their findings are often strengthened through cross-validation with orthogonal experimental methods. This guide provides an objective comparison of the performance of various spectroscopic techniques with alternative methods, supported by experimental data, detailed protocols, and visual workflows to aid researchers, scientists, and drug development professionals in their analytical endeavors.

Quantitative Data Presentation: A Side-by-Side Comparison

The following tables summarize quantitative data from various studies, offering a clear comparison of spectroscopic methods with other analytical techniques.

Table 1: Comparison of UV-Visible Spectroscopy and High-Performance Liquid Chromatography (HPLC) for the Quantification of Repaglinide in Tablets

Parameter	UV-Visible Spectroscopy	HPLC
Linearity Range ($\mu\text{g/mL}$)	5-30	5-50
Correlation Coefficient (r^2)	> 0.999	> 0.999
Precision (% RSD)	< 1.50	< 1.50
Mean Recovery (%)	99.63 - 100.45	99.71 - 100.25

Source: Data compiled from a comparative study on the determination of repaglinide in tablets[1]. This table demonstrates that both UV-Vis spectroscopy and HPLC exhibit excellent linearity and precision for the quantification of repaglinide, with HPLC showing a slightly better recovery range[1].

Table 2: Comparison of Near-Infrared (NIR) Spectroscopy and UV Assay for Tablet Content Uniformity

Parameter	NIR Spectroscopy	UV Assay
Mean %API Difference	2.32%	-
Maximum %API Difference	4.29%	-
Mean Range of API Content Difference	2.85%	-
Maximum Range of API Content Difference	6.28%	-
Standard Error of Calibration (SEC)	1.13 mg	-
Standard Error of Prediction (SEP)	1.36 mg	-

Source: Data from studies on the high-throughput analysis of pharmaceutical tablet content uniformity[2][3]. These results indicate a good agreement between NIR spectroscopy and the standard UV assay for determining the active pharmaceutical ingredient (API) content in tablets[2].

Table 3: Comparison of Mass Spectrometry and ELISA for Protein Quantification

Parameter	Mass Spectrometry (Targeted Proteomics)	Enzyme-Linked Immunosorbent Assay (ELISA)
Correlation (R)	0.97 (in a comparative study)	-
Sensitivity	High, capable of detecting low abundant proteins	High, with a larger dynamic range
Throughput	Can be high with automation	High, suitable for large sample numbers
Sample Preparation	Complex	Simpler

Source: Data from a platform cross-validation study of immunoaffinity mass spectrometry versus ELISA and a review on protein quantitation methods[4]. This comparison highlights the strong correlation between the two methods, with mass spectrometry offering detailed molecular information and ELISA providing a simpler, high-throughput workflow for targeted protein quantification[4].

Table 4: Comparison of Quantitative NMR (qNMR) and HPLC for Purity Assessment

Parameter	Quantitative NMR (qNMR)	HPLC
Principle	Quantification based on the direct proportionality between signal integral and the number of nuclei.	Separation based on differential partitioning between a stationary and mobile phase.
Universality	Applicable to nearly all organic molecules with NMR-active nuclei.	Requires a chromophore for UV detection; other detectors are available.
Selectivity	Excellent for structural confirmation and identification of impurities.	High selectivity for separating structurally similar impurities.
Sensitivity	Generally lower than HPLC, but can be enhanced.	Generally offers higher sensitivity for trace impurity analysis.

Source: Information compiled from a comparative guide on purity validation[5][6][7]. This table illustrates the orthogonal nature of qNMR and HPLC, with qNMR providing absolute quantification and structural information, while HPLC excels in separation and sensitivity[7].

Experimental Protocols

Detailed methodologies are crucial for the reproducibility and validation of experimental results. Below are generalized protocols for key experiments cited in the comparative data.

Protocol 1: Cross-Validation of a Spectroscopic Method (e.g., UV-Vis) with a Chromatographic Method (e.g., HPLC) for Drug Quantification

- Objective: To validate the accuracy and precision of a UV-Vis spectrophotometric method for the quantification of an active pharmaceutical ingredient (API) in a tablet formulation against a validated HPLC method.
- Materials:

- API reference standard
- Tablet formulation containing the API
- Solvents and reagents for both UV-Vis and HPLC analysis
- Calibrated UV-Vis spectrophotometer and HPLC system
- Method Validation Parameters (as per ICH guidelines):
 - Specificity: Analyze the drug substance, placebo, and a mixture to ensure no interference from excipients at the analytical wavelength for UV-Vis and at the retention time for HPLC.
 - Linearity: Prepare a series of standard solutions of the API at different concentrations (e.g., 5-30 µg/mL). For UV-Vis, measure the absorbance at the wavelength of maximum absorption (λ_{max}). For HPLC, inject the standards and record the peak area. Plot a calibration curve of absorbance/peak area versus concentration and determine the correlation coefficient (r^2).
 - Precision:
 - Repeatability (Intra-day precision): Analyze multiple preparations of the same sample on the same day and calculate the relative standard deviation (%RSD).
 - Intermediate Precision (Inter-day precision): Analyze the same sample on different days by different analysts to assess the method's robustness.
 - Accuracy (Recovery): Perform recovery studies by spiking a known amount of the API into the placebo at different concentration levels (e.g., 80%, 100%, 120%). Analyze the samples and calculate the percentage recovery.
- Cross-Validation Procedure:
 - Prepare a set of tablet samples for analysis.
 - Analyze each sample using both the developed UV-Vis method and the validated HPLC method.

- Statistically compare the quantitative results obtained from both methods (e.g., using a t-test) to determine if there is a significant difference between the two methods.

Protocol 2: Cross-Validation of Mass Spectrometry with ELISA for Protein Quantification

- Objective: To cross-validate the quantification of a target protein in a biological matrix using a targeted mass spectrometry-based assay and a sandwich ELISA.
- Materials:
 - Biological samples (e.g., plasma, cell lysate)
 - Recombinant protein standard of the target protein
 - Antibodies for ELISA (capture and detection)
 - Reagents for protein digestion and peptide purification for mass spectrometry
 - Calibrated mass spectrometer (e.g., LC-MS/MS) and ELISA plate reader
- Mass Spectrometry (Targeted Proteomics) Protocol:
 - Sample Preparation: Spike a known amount of a stable isotope-labeled internal standard peptide into the samples. Perform protein digestion (e.g., with trypsin) to generate peptides.
 - LC-MS/MS Analysis: Separate the peptides using liquid chromatography and detect and quantify the target peptide and its internal standard using selected reaction monitoring (SRM) or multiple reaction monitoring (MRM) on the mass spectrometer.
 - Quantification: Calculate the concentration of the target protein based on the ratio of the peak areas of the endogenous peptide to the internal standard peptide.
- ELISA Protocol:
 - Assay Procedure: Coat a 96-well plate with the capture antibody. Add the biological samples and standards to the wells. Add the detection antibody, followed by a substrate to

generate a colorimetric signal.

- Quantification: Measure the absorbance using a plate reader and determine the concentration of the target protein in the samples by interpolating from a standard curve generated using the recombinant protein standard.
- Cross-Validation Analysis:
 - Analyze the same set of biological samples using both the mass spectrometry and ELISA methods.
 - Perform a correlation analysis (e.g., Pearson correlation) to assess the agreement between the quantitative results obtained from the two platforms.

Mandatory Visualizations

The following diagrams, created using the DOT language, illustrate key signaling pathways and experimental workflows relevant to the cross-validation of spectroscopic data.

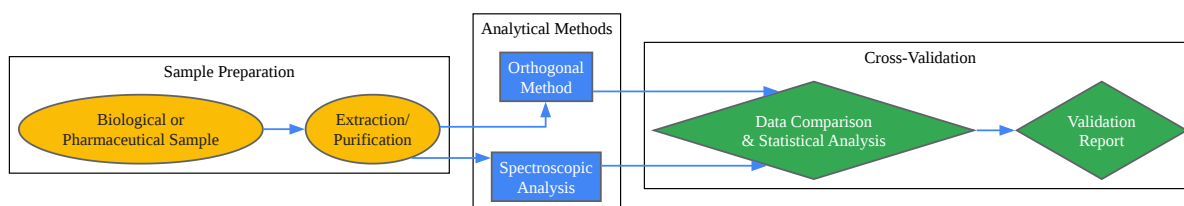

[Click to download full resolution via product page](#)

Caption: A generalized workflow for the cross-validation of spectroscopic data with an orthogonal method.

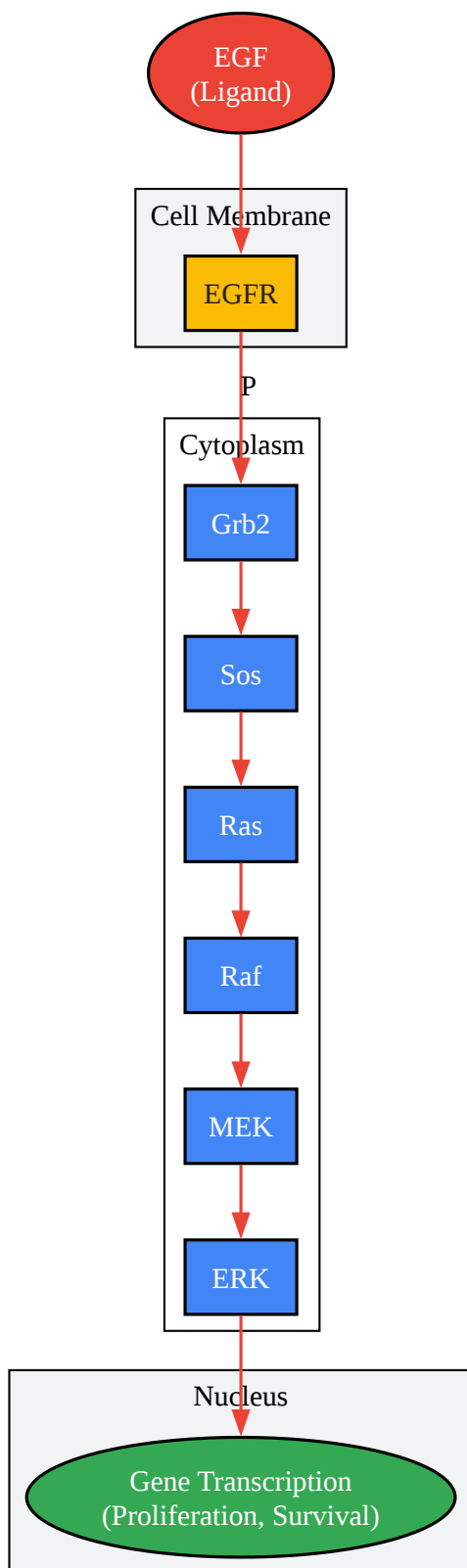

[Click to download full resolution via product page](#)

Caption: A simplified diagram of the EGFR signaling pathway, often studied using mass spectrometry.

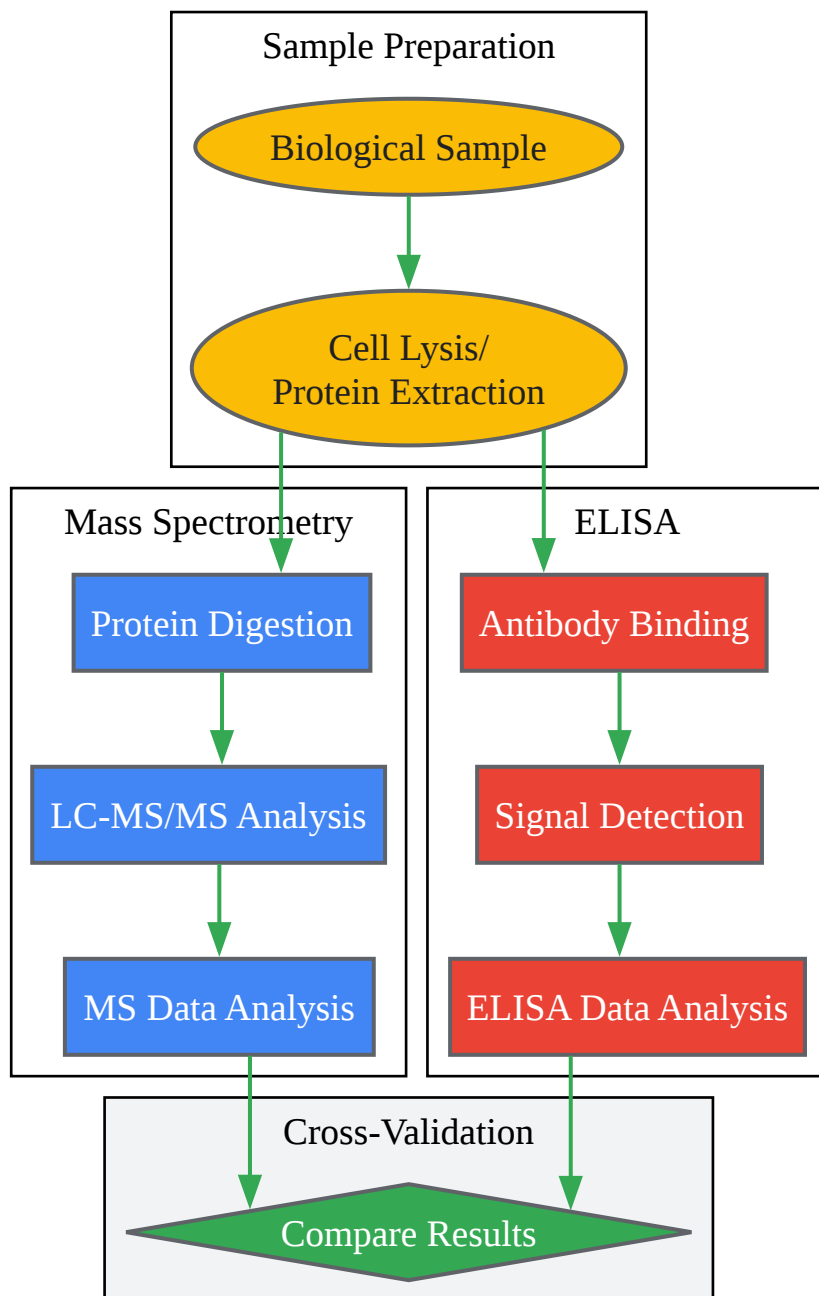

[Click to download full resolution via product page](#)

Caption: A workflow comparing protein quantification by mass spectrometry and ELISA.

Need Custom Synthesis?

BenchChem offers custom synthesis for rare earth carbides and specific isotopic labeling.

Email: info@benchchem.com or [Request Quote Online](#).

References

- [1. horiba.com \[horiba.com\]](https://horiba.com)
- [2. Analytical Method Validation in Pharmaceuticals | Step-by-Step Guide to AMV | Pharmaguideline \[pharmaguideline.com\]](#)
- [3. azom.com \[azom.com\]](https://azom.com)
- [4. blog.cellsignal.com \[blog.cellsignal.com\]](https://blog.cellsignal.com)
- [5. Validation of UV spectrophotometric and nonaqueous titration methods for the determination of carvedilol in pharmaceutical formulations - PubMed \[pubmed.ncbi.nlm.nih.gov\]](#)
- [6. Quantitative Raman Chemical Imaging of Intracellular Drug-Membrane Aggregates and Small Molecule Drug Precipitates In Cytoplasmic Organelles - PMC \[pmc.ncbi.nlm.nih.gov\]](#)
- [7. researchgate.net \[researchgate.net\]](https://researchgate.net)
- To cite this document: BenchChem. [Cross-Validation of Spectroscopic Data: A Comparative Guide for Researchers]. BenchChem, [2026]. [Online PDF]. Available at: [\[https://www.benchchem.com/product/b2623350/docs#cross-validation-of-spectroscopic-data-a-comparative-guide-for-researchers\]](https://www.benchchem.com/product/b2623350/docs#cross-validation-of-spectroscopic-data-a-comparative-guide-for-researchers)

Disclaimer & Data Validity:

The information provided in this document is for Research Use Only (RUO) and is strictly not intended for diagnostic or therapeutic procedures. While BenchChem strives to provide accurate protocols, we make no warranties, express or implied, regarding the fitness of this product for every specific experimental setup.

Technical Support: The protocols provided are for reference purposes. Unsure if this reagent suits your experiment?

Need Industrial/Bulk Grade? [Request Custom Synthesis Quote](#)

BenchChem

Our mission is to be the trusted global source of essential and advanced chemicals, empowering scientists and researchers to drive progress in science and industry.

Contact

Address: 3281 E Guasti Rd

Ontario, CA 91761, United States

Phone: (601) 213-4426

Email: info@benchchem.com

[Contact our Ph.D. Support Team for a compatibility check](#)