

Technical Support Center: Mitigation of 2-Pyridyl Boronic Ester Protodeboronation

Author: BenchChem Technical Support Team. **Date:** May 2026

Compound of Interest

Compound Name: 6-Amino-3-bromopyridin-2-ol

CAS No.: 610279-06-6

Cat. No.: B2621750

[Get Quote](#)

This guide provides in-depth technical support for researchers, scientists, and drug development professionals encountering protodeboronation of 2-pyridyl boronic esters in their synthetic workflows. Here, we dissect the underlying mechanisms of this common side reaction and offer field-proven troubleshooting strategies and detailed protocols to ensure the success of your cross-coupling reactions.

Understanding the "2-Pyridyl Problem"

The 2-pyridyl boronic acid and its esters are notoriously unstable reagents in synthetic chemistry, primarily due to their high susceptibility to protodeboronation.^{[1][2]} This reaction involves the cleavage of the carbon-boron (C-B) bond and its replacement with a carbon-hydrogen (C-H) bond, leading to the formation of the corresponding unsubstituted pyridine as a major byproduct and significantly reducing the yield of the desired cross-coupled product.^{[3][4]}

The instability of 2-pyridyl boronic esters stems from the electron-deficient nature of the pyridine ring and the presence of the basic nitrogen atom at the 2-position.^{[3][4]} This unique electronic arrangement facilitates a unimolecular fragmentation pathway, especially under

neutral pH conditions, where a zwitterionic intermediate is formed that readily undergoes C-B bond cleavage.[3][5][6]

Troubleshooting Guide: Minimizing Protodeboronation

This section addresses common issues and provides actionable solutions to mitigate protodeboronation during your experiments.

FAQ 1: My Suzuki-Miyaura reaction with a 2-pyridyl boronic ester is giving low yields and a significant amount of the deboronated pyridine. What are the primary causes?

Several factors can contribute to excessive protodeboronation. The most common culprits are:

- **Reaction pH:** The rate of protodeboronation is highly pH-dependent.[5][6][7] While basic conditions are necessary for the Suzuki-Miyaura catalytic cycle, excessively strong bases or prolonged reaction times at high pH can accelerate the decomposition of the 2-pyridyl boronic ester.
- **Temperature:** Higher reaction temperatures increase the rate of all reactions, including the undesired protodeboronation.[4]
- **Water Content:** While a controlled amount of water is often required for the hydrolysis of the boronate ester to the active boronic acid, excess water can promote protodeboronation.[4]
- **Catalyst Activity:** If the rate of the desired cross-coupling reaction is slow, the sensitive 2-pyridyl boronic ester has more time to decompose.

FAQ 2: How can I modify my reaction conditions to favor the desired cross-coupling over protodeboronation?

Optimizing your reaction parameters is the first line of defense against protodeboronation.

- **Choice of Base:** Employ weaker bases such as potassium carbonate (K_2CO_3), potassium phosphate (K_3PO_4), or cesium carbonate (Cs_2CO_3) instead of strong bases like sodium hydroxide (NaOH) or potassium hydroxide (KOH).[4] Weaker bases can provide a sufficient rate of transmetalation for the Suzuki coupling while minimizing the rate of protodeboronation.
- **Temperature Control:** Run the reaction at the lowest temperature that still allows for a reasonable rate of product formation. A temperature screen is often a worthwhile optimization step.
- **Solvent System:** Carefully control the amount of water in your solvent system. Using a mixed solvent system like dioxane/water or toluene/water is common, but the ratio should be optimized. In some cases, anhydrous conditions may be beneficial if compatible with your catalyst system.
- **High-Activity Catalysts:** Utilize highly active palladium catalysts and ligands, such as those from the Buchwald or SPhos families.[8][9] A more efficient catalyst will increase the rate of the desired Suzuki-Miyaura coupling, allowing it to outcompete the protodeboronation side reaction.[3]

Advanced Strategies: Utilizing Stabilized Boron Reagents

When optimizing reaction conditions is insufficient, employing stabilized 2-pyridyl boron reagents is a highly effective strategy.

FAQ 3: I've optimized my conditions, but protodeboronation is still a major issue. What are my options for more stable 2-pyridyl boron reagents?

Several classes of stabilized 2-pyridyl boron reagents have been developed to overcome the inherent instability of the simple boronic acids and esters.

- **MIDA Boronates (N-methyliminodiacetic acid boronates):** These are air- and moisture-stable crystalline solids that can be purified by silica gel chromatography.[10][11] MIDA boronates act as a "slow-release" source of the boronic acid under mild aqueous basic conditions.[3]

[10][11] This slow release maintains a low concentration of the unstable boronic acid in the reaction mixture, favoring the cross-coupling reaction over decomposition.[3][10]

- Organotrifluoroborates (BF₃K): Potassium 2-pyridyltrifluoroborate is another air-stable, crystalline solid.[11] Similar to MIDA boronates, they slowly release the boronic acid under the reaction conditions.
- Diethanolamine (DEA) and N-Phenyldiethanolamine (PDEA) Adducts: These form stable five-membered ring structures with the boron atom, significantly enhancing their stability.[11][12]

The choice of which stabilized reagent to use will depend on the specific substrates and reaction conditions of your synthesis.

Comparative Stability of 2-Pyridyl Boron Reagents

Boron Reagent Type	Stability	Handling	Release Mechanism
Boronic Acid	Low	Prone to rapid decomposition	-
Pinacol Ester	Moderate	More stable than the acid, but still susceptible to hydrolysis and protodeboronation	Hydrolysis to boronic acid
MIDA Boronate	High	Air- and moisture-stable solid	Slow hydrolysis under basic conditions[10][11]
Trifluoroborate	High	Air-stable, crystalline solid	Slow hydrolysis[11]
DEA/PDEA Adducts	High	Stable solids	Hydrolysis

Experimental Protocols

Protocol 1: General Procedure for Suzuki-Miyaura Coupling Using a 2-Pyridyl MIDA Boronate

This protocol provides a starting point for the cross-coupling of a 2-pyridyl MIDA boronate with an aryl halide.

Materials:

- 2-Pyridyl MIDA boronate (1.0 equiv)
- Aryl halide (1.2 equiv)
- Palladium catalyst (e.g., Pd(OAc)₂, 2 mol%)
- Ligand (e.g., SPhos, 4 mol%)
- Base (e.g., K₃PO₄, 3.0 equiv)
- Solvent (e.g., Dioxane/Water, 5:1 v/v)
- Anhydrous, degassed solvents

Procedure:

- To a dry reaction vessel, add the 2-pyridyl MIDA boronate, aryl halide, palladium catalyst, ligand, and base.
- Evacuate and backfill the vessel with an inert atmosphere (e.g., nitrogen or argon) three times.
- Add the degassed dioxane/water solvent mixture via syringe.
- Heat the reaction mixture to 80-100 °C with vigorous stirring.
- Monitor the reaction progress by a suitable analytical technique (e.g., TLC, LC-MS, or GC-MS).
- Upon completion, cool the reaction mixture to room temperature.

- Dilute the mixture with an organic solvent (e.g., ethyl acetate) and wash with water and brine.
- Dry the organic layer over anhydrous sodium sulfate or magnesium sulfate, filter, and concentrate under reduced pressure.
- Purify the crude product by flash column chromatography.

Visualizing the Solution: A Workflow for Troubleshooting

The following diagram illustrates a logical workflow for addressing the protodeboronation of 2-pyridyl boronic esters.

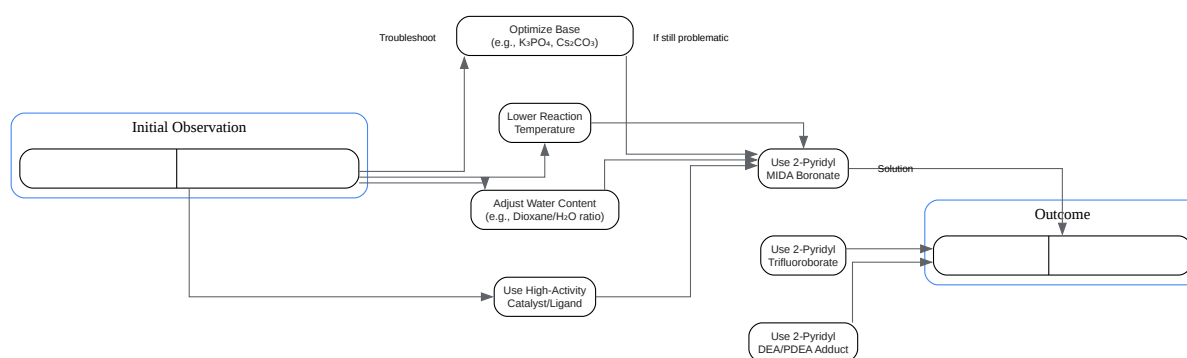

[Click to download full resolution via product page](#)

Need Custom Synthesis?

BenchChem offers custom synthesis for rare earth carbides and specific isotopic labeling.

Email: info@benchchem.com or [Request Quote Online](#).

Sources

- [1. researchgate.net \[researchgate.net\]](#)
- [2. researchgate.net \[researchgate.net\]](#)
- [3. Protodeboronation - Wikipedia \[en.wikipedia.org\]](#)
- [4. pdf.benchchem.com \[pdf.benchchem.com\]](#)
- [5. Protodeboronation of Heteroaromatic, Vinyl, and Cyclopropyl Boronic Acids: pH-Rate Profiles, Autocatalysis, and Disproportionation - PubMed \[pubmed.ncbi.nlm.nih.gov\]](#)
- [6. semanticscholar.org \[semanticscholar.org\]](#)
- [7. researchonline.ljmu.ac.uk \[researchonline.ljmu.ac.uk\]](#)
- [8. scientificupdate.com \[scientificupdate.com\]](#)
- [9. reddit.com \[reddit.com\]](#)
- [10. A General Solution for the 2-Pyridyl Problem - PMC \[pmc.ncbi.nlm.nih.gov\]](#)
- [11. benchchem.com \[benchchem.com\]](#)
- [12. researchgate.net \[researchgate.net\]](#)
- To cite this document: BenchChem. [Technical Support Center: Mitigation of 2-Pyridyl Boronic Ester Protodeboronation]. BenchChem, [2026]. [Online PDF]. Available at: [<https://www.benchchem.com/product/b2621750/docs#technical-support-center-mitigation-of-2-pyridyl-boronic-ester-protodeboronation>]

Disclaimer & Data Validity:

The information provided in this document is for Research Use Only (RUO) and is strictly not intended for diagnostic or therapeutic procedures. While BenchChem strives to provide accurate protocols, we make no warranties, express or implied, regarding the fitness of this product for every specific experimental setup.

Technical Support: The protocols provided are for reference purposes. Unsure if this reagent suits your experiment?

Need Industrial/Bulk Grade? [Request Custom Synthesis Quote](#)

BenchChem

Our mission is to be the trusted global source of essential and advanced chemicals, empowering scientists and researchers to drive progress in science and industry.

Contact

Address: 3281 E Guasti Rd
Ontario, CA 91761, United States
Phone: (601) 213-4426
Email: info@benchchem.com

[Contact our Ph.D. Support Team for a compatibility check](#)