

An In-Depth Technical Guide to Oxepane-4-carboxaldehyde

Author: BenchChem Technical Support Team. **Date:** May 2026

Compound of Interest

Compound Name: Oxepane-4-carbaldehyde

CAS No.: 1369165-85-4

Cat. No.: B2621638

[Get Quote](#)

Abstract

This technical guide provides a comprehensive overview of oxepane-4-carboxaldehyde, a heterocyclic compound of interest in medicinal chemistry and synthetic organic chemistry. The oxepane scaffold is a key structural motif in a variety of biologically active natural products, and its derivatives are valuable building blocks for the synthesis of novel therapeutic agents.^[1] This document details the nomenclature, structural identifiers, and physicochemical properties of oxepane-4-carboxaldehyde. Furthermore, it outlines plausible synthetic strategies, predicted spectroscopic data, chemical reactivity, and potential applications, offering a valuable resource for researchers, scientists, and professionals in drug development.

Introduction

The oxepane ring, a seven-membered saturated heterocycle containing an oxygen atom, is a prominent feature in numerous marine-derived natural products with a wide range of biological activities, including anticancer, antibacterial, and antifungal properties.^[1] The incorporation of the oxepane moiety into molecular structures can significantly influence their conformational preferences, lipophilicity, and metabolic stability, making it an attractive scaffold in drug

discovery. Oxepane-4-carboxaldehyde, as a functionalized derivative, represents a versatile synthetic intermediate for the introduction of the oxepane motif and for the construction of more complex molecular architectures.

Nomenclature and Structural Identifiers

The systematic identification of a chemical entity is paramount for unambiguous communication in research and development. The structural identifiers for oxepane-4-carboxaldehyde are provided below.

Identifier	Value
Systematic Name	oxepane-4-carbaldehyde
Molecular Formula	C ₇ H ₁₂ O ₂
Molecular Weight	128.17 g/mol
SMILES	<chem>C1CC(CCOC1)C=O</chem>
InChI	InChI=1S/C7H12O2/c8-6-7-2-1-4-9-5-3-7/h6-7H,1-5H2

Synthesis of Oxepane-4-carboxaldehyde

While a specific, documented protocol for the synthesis of oxepane-4-carboxaldehyde is not readily available in the literature, its preparation can be envisioned through established synthetic methodologies for oxepanes and the functionalization of cyclic ethers. A plausible and efficient route would involve the oxidation of the corresponding primary alcohol, oxepan-4-ylmethanol.

Proposed Synthetic Protocol: Oxidation of Oxepan-4-ylmethanol

This protocol describes a hypothetical, yet chemically sound, procedure for the synthesis of oxepane-4-carboxaldehyde from its alcohol precursor. The choice of a mild oxidizing agent, such as pyridinium chlorochromate (PCC), is crucial to prevent over-oxidation to the carboxylic acid.

Reaction Scheme:

A proposed synthesis of oxepane-4-carboxaldehyde.

Materials and Equipment:

- Oxepan-4-ylmethanol
- Pyridinium chlorochromate (PCC)
- Dichloromethane (DCM), anhydrous
- Silica gel for column chromatography
- Round-bottom flask
- Magnetic stirrer
- Standard glassware for organic synthesis and work-up
- Rotary evaporator

Experimental Procedure:

- **Reaction Setup:** To a solution of oxepan-4-ylmethanol (1.0 eq) in anhydrous dichloromethane (DCM) in a round-bottom flask under an inert atmosphere, add pyridinium chlorochromate (PCC) (1.5 eq) in one portion.
- **Reaction:** Stir the resulting suspension at room temperature. Monitor the reaction progress by thin-layer chromatography (TLC) until the starting material is consumed.
- **Work-up:** Upon completion, dilute the reaction mixture with diethyl ether and filter through a pad of silica gel to remove the chromium salts. Wash the silica gel pad with additional diethyl ether.
- **Purification:** Concentrate the filtrate under reduced pressure using a rotary evaporator. Purify the crude product by flash column chromatography on silica gel using an appropriate eluent

system (e.g., a gradient of ethyl acetate in hexanes) to afford pure oxepane-4-carboxaldehyde.

Spectroscopic Characterization

The structural elucidation of oxepane-4-carboxaldehyde relies on a combination of spectroscopic techniques. While experimental data is not widely published, the expected spectral features can be predicted based on the known chemical shifts and absorption frequencies of similar structural motifs.

Nuclear Magnetic Resonance (NMR) Spectroscopy

¹H NMR: The proton NMR spectrum is expected to show a characteristic downfield signal for the aldehydic proton. The protons on the oxepane ring will appear as a series of multiplets in the upfield region.

¹³C NMR: The carbon NMR spectrum will be distinguished by the downfield resonance of the carbonyl carbon of the aldehyde. The carbons of the oxepane ring will appear in the aliphatic region, with those adjacent to the oxygen atom shifted downfield.

Predicted NMR Data:

Atom	Predicted ¹ H Chemical Shift (ppm)	Predicted ¹³ C Chemical Shift (ppm)
CHO	~9.7 (s)	~203
C4-H	~2.5 (m)	~50
CH ₂ -O	~3.7 (m)	~70
Ring CH ₂	1.6-2.0 (m)	25-35

Infrared (IR) Spectroscopy

The IR spectrum of oxepane-4-carboxaldehyde will exhibit characteristic absorption bands for the aldehyde and ether functional groups.

- C=O Stretch (Aldehyde): A strong, sharp absorption band is expected in the region of 1720-1740 cm^{-1} .
- C-H Stretch (Aldehyde): Two weak to medium bands are anticipated around 2720 cm^{-1} and 2820 cm^{-1} .
- C-O Stretch (Ether): A strong absorption band is expected in the range of 1050-1150 cm^{-1} .
- C-H Stretch (Aliphatic): Multiple bands will be present in the 2850-3000 cm^{-1} region.

Mass Spectrometry (MS)

In the mass spectrum, the molecular ion peak ($[M]^+$) would be observed at $m/z = 128$. The fragmentation pattern is expected to be influenced by the presence of both the aldehyde and the oxepane ring.

Predicted Fragmentation Pathways:

- Loss of H \cdot : A fragment at $m/z = 127$ ($[M-H]^+$) resulting from the loss of the aldehydic proton.
- Loss of CHO \cdot : A significant fragment at $m/z = 99$ ($[M-CHO]^+$) due to the cleavage of the formyl group.
- α -Cleavage: Cleavage of the C-C bond adjacent to the oxygen atom in the ring, leading to various smaller fragments.

Chemical Reactivity and Synthetic Utility

Oxepane-4-carboxaldehyde is expected to exhibit reactivity characteristic of aliphatic aldehydes, making it a useful intermediate in organic synthesis. The oxepane ring is generally stable under a variety of reaction conditions.

Reactions of the Aldehyde Group

The aldehyde functionality can undergo a wide range of transformations, providing access to a diverse array of derivatives.

- Oxidation: Can be oxidized to the corresponding carboxylic acid, oxepane-4-carboxylic acid, using oxidizing agents like potassium permanganate or Jones reagent.
- Reduction: Can be reduced to the primary alcohol, oxepan-4-ylmethanol, using reducing agents such as sodium borohydride or lithium aluminum hydride.
- Nucleophilic Addition: The carbonyl carbon is electrophilic and will react with various nucleophiles, including Grignard reagents, organolithium compounds, and cyanide.
- Wittig Reaction: Reacts with phosphorus ylides to form alkenes.
- Condensation Reactions: Can undergo aldol condensation and other related reactions with enolates and other carbon nucleophiles.

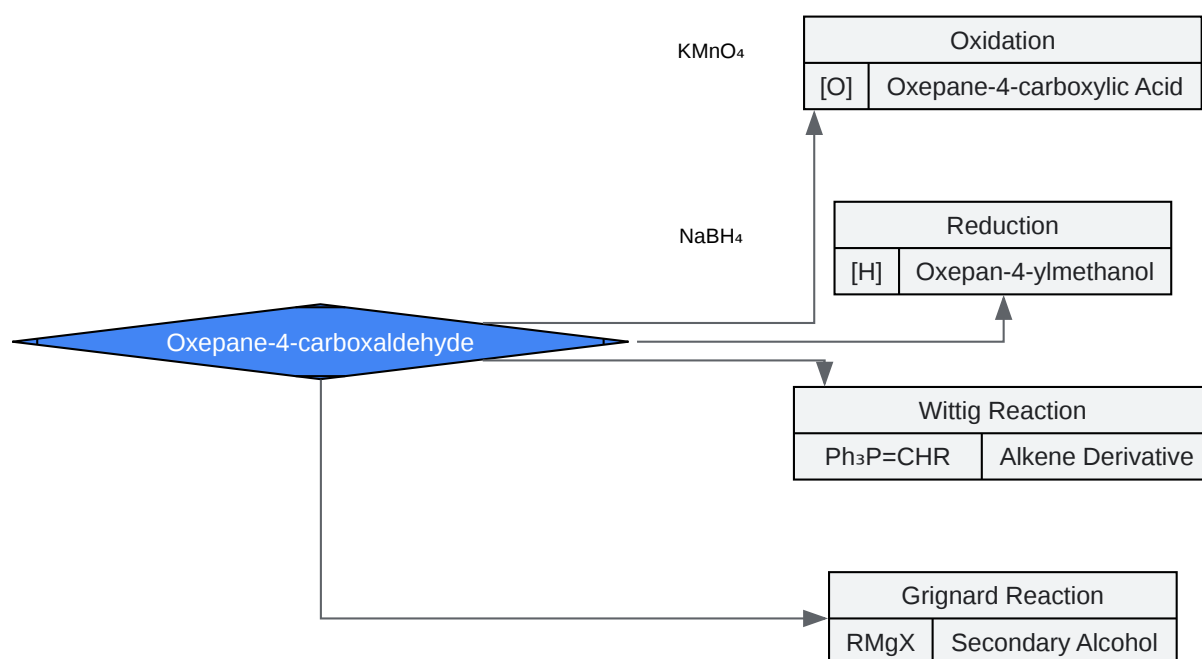

[Click to download full resolution via product page](#)

Key reactions of oxepane-4-carboxaldehyde.

Applications in Research and Drug Discovery

The oxepane motif is of significant interest in medicinal chemistry due to its presence in numerous bioactive natural products and its ability to modulate the physicochemical properties of drug candidates.[1][2] Oxepane-4-carboxaldehyde serves as a valuable building block for the synthesis of more complex molecules containing the oxepane scaffold.

Its aldehyde functionality allows for its incorporation into larger structures through a variety of carbon-carbon and carbon-heteroatom bond-forming reactions. This makes it a useful starting material for the preparation of libraries of oxepane-containing compounds for screening in drug discovery programs. The development of synthetic routes to novel dipeptide building blocks containing cyclic ethers like oxetanes highlights the interest in such scaffolds for creating peptidomimetics with improved properties.[3]

Conclusion

Oxepane-4-carboxaldehyde is a functionalized heterocyclic compound with significant potential as a synthetic intermediate in medicinal chemistry and organic synthesis. While detailed experimental data for this specific molecule is sparse in the public domain, its synthesis, spectroscopic characteristics, and reactivity can be reliably predicted based on established chemical principles. The strategic importance of the oxepane scaffold in drug discovery underscores the value of oxepane-4-carboxaldehyde as a building block for the development of novel therapeutic agents.

References

- The Oxepane Motif in Marine Drugs. *Mar. Drugs* 2017, 15(11), 361. [[Link](#)]
- PubChem Compound Summary for CID 13545938, **Oxepane-4-carbaldehyde**. National Center for Biotechnology Information. [[Link](#)]
- Advancements in the synthesis of polyoxygenated oxepanes and thiepanes for applications to natural products. *Org. Biomol. Chem.*, 2024, Advance Article. [[Link](#)]
- Synthesis of α,α' -trans-Oxepanes through an Organocatalytic Oxa-conjugate Addition Reaction. *Org. Lett.* 2014, 16(8), 2216–2219. [[Link](#)]

- Development of oxetane modified building blocks for peptide synthesis. Org. Biomol. Chem., 2020, 18, 5400-5405. [[Link](#)]

Need Custom Synthesis?

BenchChem offers custom synthesis for rare earth carbides and specific isotopic labeling.

Email: info@benchchem.com or [Request Quote Online](#).

Sources

- [1. Advancements in the synthesis of polyoxygenated oxepanes and thiepanes for applications to natural products - Organic Chemistry Frontiers \(RSC Publishing\)](#) DOI:10.1039/D4QO00380B [pubs.rsc.org]
- [2. scispace.com](#) [scispace.com]
- [3. Development of oxetane modified building blocks for peptide synthesis - PubMed](#) [pubmed.ncbi.nlm.nih.gov]
- To cite this document: BenchChem. [An In-Depth Technical Guide to Oxepane-4-carboxaldehyde]. BenchChem, [2026]. [Online PDF]. Available at: [<https://www.benchchem.com/product/b2621638/docs#an-in-depth-technical-guide-to-oxepane-4-carboxaldehyde>]

Disclaimer & Data Validity:

The information provided in this document is for Research Use Only (RUO) and is strictly not intended for diagnostic or therapeutic procedures. While BenchChem strives to provide accurate protocols, we make no warranties, express or implied, regarding the fitness of this product for every specific experimental setup.

Technical Support: The protocols provided are for reference purposes. Unsure if this reagent suits your experiment?

Need Industrial/Bulk Grade? [Request Custom Synthesis Quote](#)

BenchChem

Our mission is to be the trusted global source of essential and advanced chemicals, empowering scientists and researchers to drive progress in science and industry.

Contact

Address: 3281 E Guasti Rd

Ontario, CA 91761, United States

Phone: (601) 213-4426

Email: info@benchchem.com

[Contact our Ph.D. Support Team for a compatibility check](#)