

Technical Guide: Structural Validation of N1- vs. N3-Substituted 2-Aminoimidazoles

Author: BenchChem Technical Support Team. **Date:** May 2026

Compound of Interest

Compound Name: *1-(3-Bromobenzyl)-1H-imidazol-2-amine*

CAS No.: *1183265-86-2*

Cat. No.: *B2620812*

[Get Quote](#)

Executive Summary

The 2-aminoimidazole (2-AI) scaffold is a privileged structure in medicinal chemistry, critical for developing biofilm inhibitors, adrenergic receptor ligands, and kinase inhibitors. However, the scaffold presents a persistent challenge: annular tautomerism.^[1]

When alkylating a 4-substituted 2-aminoimidazole, two constitutional isomers are generated. While often colloquially referred to as "N1-substituted" and "N3-substituted" relative to the starting material, IUPAC conventions renumber these as 1,4-disubstituted (distal) and 1,5-disubstituted (proximal) isomers.

Misassigning these isomers is a critical failure mode in Structure-Activity Relationship (SAR) studies.^[1] This guide provides a definitive, self-validating workflow to distinguish these regioisomers using NMR spectroscopy (NOESY/HMBC) and chemical synthesis, moving beyond reliance on unstable melting points or ambiguous mass spectrometry.

Part 1: The Regioselectivity Conundrum

The Tautomeric Trap

In solution, 4-substituted-2-aminoimidazoles exist in rapid equilibrium. The proton shuttles between the two ring nitrogens (N1 and N3).[1] When an electrophile (R-X) is introduced, the reaction can occur at either nitrogen.[1]

- Steric Control: Favors alkylation at the nitrogen distal to the C4-substituent (yielding the 1,4-isomer).
- Electronic Control: Electron-withdrawing groups (EWG) at C4 can increase the acidity of the adjacent NH, often directing alkylation to the remote nitrogen, but specific coordination effects (e.g., with NaH) can invert this selectivity.[1]

Because both products share the exact same mass and similar polarity, standard LC-MS is insufficient for structural assignment.

Visualization: The Divergent Pathway

The following diagram illustrates the alkylation bifurcation and the resulting naming convention confusion.

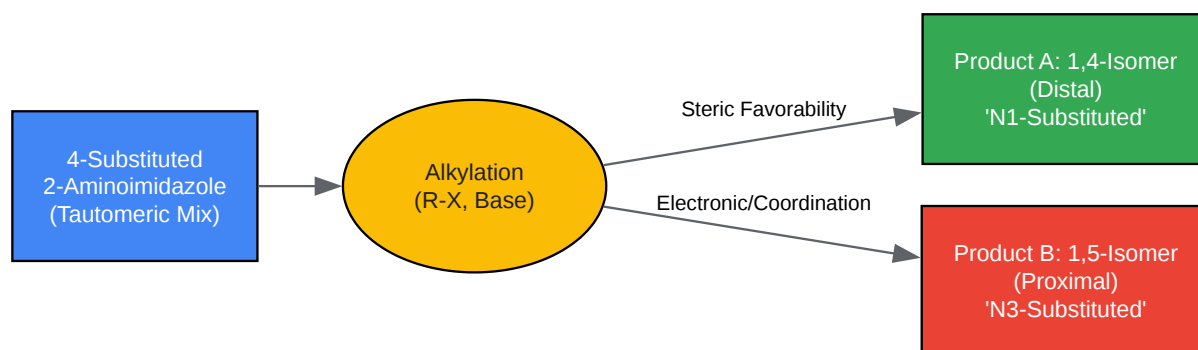

[Click to download full resolution via product page](#)

Figure 1: Divergent alkylation pathways of 2-aminoimidazoles. The "Distal" product places the alkyl group far from the C4 substituent.[1] The "Proximal" product places them adjacent.

Part 2: Comparative Analytical Performance

To validate the structure, we compare three primary methodologies. Nuclear Overhauser Effect Spectroscopy (NOESY) is the recommended industry standard for routine validation.^[1]

Feature	1D NMR (H/C)	NOESY / ROESY	X-Ray Crystallography
Differentiation Power	Low	High	Definitive
Basis of Proof	Chemical shift heuristics (unreliable without both isomers)	Through-space proximity (Spatial correlation)	Direct atom mapping
Sample Requirement	~1 mg	~5-10 mg (High Conc.)	Single Crystal
Throughput	High (10 mins)	Medium (1-4 hours)	Low (Days/Weeks)
Recommendation	Preliminary screening only	Primary Validation Tool	Final confirmation for lead compounds

Part 3: Detailed Validation Protocols

Protocol A: The "Gold Standard" NMR Assignment

This protocol relies on the spatial proximity of the introduced N-alkyl group to the protons on the imidazole ring.^[1]

Prerequisites:

- Sample concentration: >5 mg in 0.6 mL DMSO-
or CDCl₃.
- Instrument: 500 MHz or higher recommended.^[1]

Step 1: ¹H NMR Assignment

Identify the key protons:

- H-Imid: The singlet proton on the imidazole ring (C5-H in 1,4-isomer; C4-H in 1,5-isomer). Usually found between 6.5 – 7.5 ppm.^[1]
- H-Alkyl: The protons on the carbon directly attached to the ring nitrogen (N-CH
- or N-CH
) . usually 3.5 – 4.0 ppm.^[1]
- H-Subst: The protons on the substituent group (e.g., Phenyl ortho-protons).

Step 2: NOESY Acquisition

Run a 2D NOESY (Nuclear Overhauser Effect Spectroscopy) experiment.

- Mixing Time: 500 ms (standard) or 800 ms (for small molecules/slow tumbling).^[1]
- Scans: Sufficient to see cross-peaks (usually 16-32 scans).

Step 3: The Decision Logic

Analyze the cross-peaks (off-diagonal spots) correlating the N-Alkyl protons to the aromatic region.

- Scenario A (1,4-Isomer / Distal):
 - Observation: Strong NOE between N-Alkyl and H-Imid (the ring proton).
 - Reasoning: In the 1,4-isomer, the N-alkyl group is at position 1, and the ring proton is at position 5. They are adjacent (distance).^[1]
 - Observation: NO NOE between N-Alkyl and H-Subst (the substituent).
- Scenario B (1,5-Isomer / Proximal):
 - Observation: Strong NOE between N-Alkyl and H-Subst (the substituent protons).

- Reasoning: In the 1,5-isomer, the N-alkyl group is at position 1, and the substituent is at position 5. They are spatially crowded.[1]
- Observation: Weak or NO NOE between N-Alkyl and H-Imid (ring proton is now at C4, far away).

Visualization: The NMR Logic Flowchart

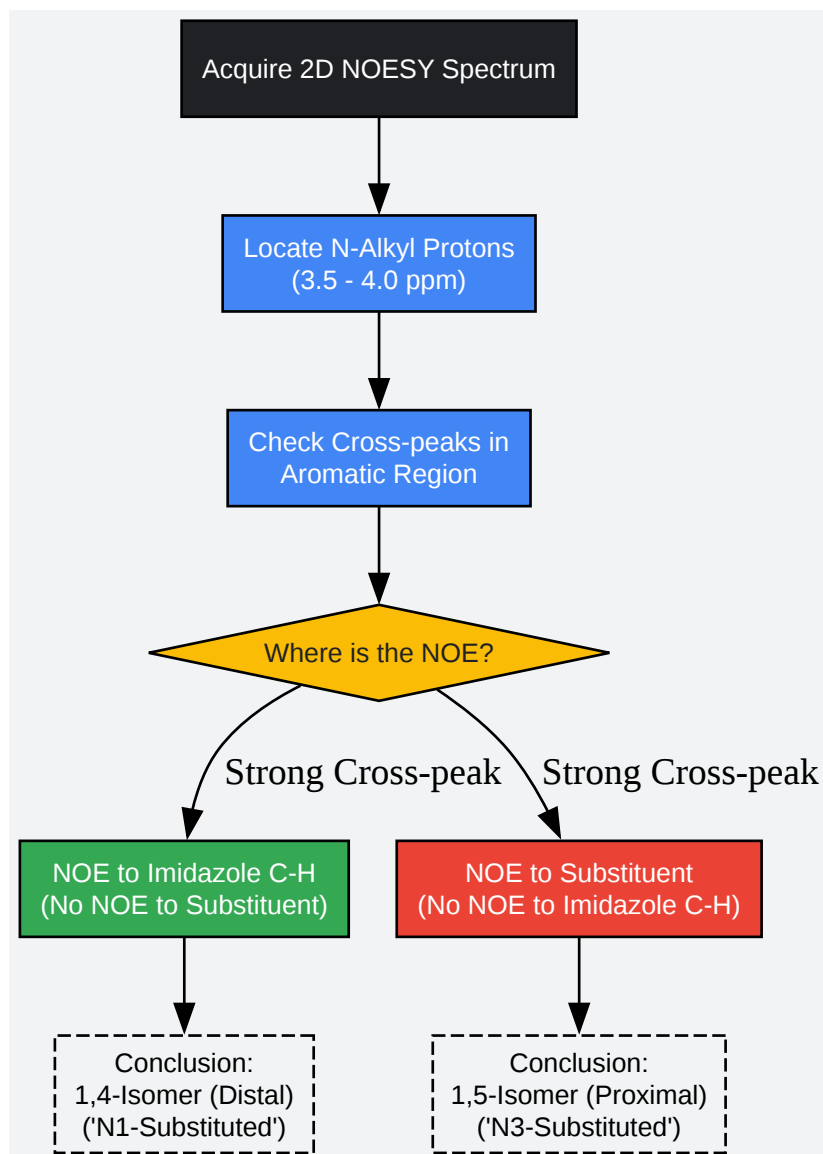

[Click to download full resolution via product page](#)

Figure 2: Decision logic for assigning regiochemistry based on NOESY data.

Protocol B: Chemical Derivatization (Regioselective Synthesis)

If NMR is ambiguous (e.g., if the substituent has no protons, like a nitro or bromo group), use regioselective synthesis to create an authentic standard.[1]

Method: Cyclization of N-substituted guanidines.[2] Instead of alkylating the ring, build the ring with the alkyl group already in place.[1]

- React:

-haloketone + N-alkylguanidine.
- Mechanism: The most nucleophilic nitrogen of the guanidine attacks the ketone.[1]
- Result: This typically yields the 1,4-isomer exclusively because the sterics of the cyclization transition state favor placing the R group away from the bulky substituent.[1]
- Compare: Compare the retention time (LC-MS) and NMR of your ambiguous alkylation product to this authentic standard.

Part 4: Case Study & Data Interpretation

Case: Methylation of 4-phenyl-2-aminoimidazole. Reagents: MeI, K

CO

, DMF.[1][3]

Parameter	Isomer A (Major Product)	Isomer B (Minor Product)
Identity	1-methyl-4-phenyl-2-aminoimidazole	1-methyl-5-phenyl-2-aminoimidazole
Yield	78%	12%
H-Imid Shift	6.95 ppm (C5-H)	7.20 ppm (C4-H)
NOESY Data	Correlation: N-Me H-Imid (6.95)	Correlation: N-Me Ph-ortho (7.40)
HMBC	N-Me correlates to C2 and C5	N-Me correlates to C2 and C5 (C5 is quaternary)

Interpretation: The major product is the 1,4-isomer (Distal).[1] The steric hindrance of the phenyl group directs the methyl iodide to the remote nitrogen.[1] The NOESY confirms this by showing the methyl group is "talking" to the ring proton, not the phenyl ring [1, 2].[1]

References

- N-Alkylation of imidazoles: Steric and Electronic Effects. Source: University of Otago Archive. [1] Summary: Detailed kinetic study on how electron-withdrawing groups and sterics influence N1 vs N3 ratios. URL:[Link][1]
- Regioselective synthesis of 1-alkyl-4-nitro-1H-imidazole. Source: Der Pharma Chemica, 2022.[1][4] Summary: Experimental validation of alkylation conditions (Base/Solvent) favoring specific regioisomers in nitro-imidazoles. URL:[Link]
- The discovery of N-1 substituted 2-aminobenzimidazoles as zinc-dependent S. aureus biofilm inhibitors. Source: National Institutes of Health (PMC), 2018.[1] Summary: Application of N1-substituted 2-aminoimidazoles in drug discovery and the importance of structural validation. URL:[Link]
- NOESY Spectra - Chemistry LibreTexts. Source: Chemistry LibreTexts.[1] Summary: Fundamental principles of using NOESY for determining stereochemical and regiochemical relationships in rigid molecules. URL:[Link]

Need Custom Synthesis?

BenchChem offers custom synthesis for rare earth carbides and specific isotopic labeling.

Email: info@benchchem.com or [Request Quote Online](#).

Sources

- [1. chem.libretexts.org \[chem.libretexts.org\]](https://chem.libretexts.org)
- [2. asianpubs.org \[asianpubs.org\]](https://asianpubs.org)
- [3. Regioselective alkylation of a versatile indazole: Electrophile scope and mechanistic insights from density functional theory calculations - PMC \[pmc.ncbi.nlm.nih.gov\]](#)
- [4. derpharmachemica.com \[derpharmachemica.com\]](https://www.derpharmachemica.com)
- To cite this document: BenchChem. [Technical Guide: Structural Validation of N1- vs. N3-Substituted 2-Aminoimidazoles]. BenchChem, [2026]. [Online PDF]. Available at: [\[https://www.benchchem.com/product/b2620812/docs#technical-guide-structural-validation-of-n1-vs-n3-substituted-2-aminoimidazoles\]](https://www.benchchem.com/product/b2620812/docs#technical-guide-structural-validation-of-n1-vs-n3-substituted-2-aminoimidazoles)

Disclaimer & Data Validity:

The information provided in this document is for Research Use Only (RUO) and is strictly not intended for diagnostic or therapeutic procedures. While BenchChem strives to provide accurate protocols, we make no warranties, express or implied, regarding the fitness of this product for every specific experimental setup.

Technical Support: The protocols provided are for reference purposes. Unsure if this reagent suits your experiment?

Need Industrial/Bulk Grade? [Request Custom Synthesis Quote](#)

BenchChem

Our mission is to be the trusted global source of essential and advanced chemicals, empowering scientists and researchers to drive progress in science and industry.

Contact

Address: 3281 E Guasti Rd

Ontario, CA 91761, United States

Phone: (601) 213-4426

Email: info@benchchem.com

[Contact our Ph.D. Support Team for a compatibility check](#)