

Technical Support Center: Controlling Regioselectivity in the Synthesis of Unsymmetrical Pyrazoles

Author: BenchChem Technical Support Team. **Date:** April 2026

Compound of Interest

Compound Name:	2-(3,5-dimethyl-1H-pyrazol-1-yl)propan-1-amine
CAS No.:	956352-78-6
Cat. No.:	B2618547

[Get Quote](#)

Welcome to the Technical Support Center for the synthesis of unsymmetrical pyrazoles. This guide is designed for researchers, scientists, and professionals in drug development who are navigating the complexities of controlling regioselectivity in their synthetic routes. Here, you will find practical, in-depth answers to common challenges, troubleshooting strategies for when your reactions do not go as planned, and detailed protocols to enhance the regioselectivity of your pyrazole synthesis.

Introduction

The pyrazole nucleus is a fundamental scaffold in a vast array of pharmaceuticals and biologically active compounds.[1][2] Consequently, the regioselective synthesis of unsymmetrically substituted pyrazoles is of paramount importance. The formation of regioisomers, which differ in the placement of substituents on the pyrazole ring, can lead to compounds with dramatically different biological activities, toxicological profiles, and physical

properties.^{[3][4]} This guide provides a focused resource to help you master the control of regioselectivity in this critical class of reactions.

Frequently Asked Questions (FAQs)

Q1: What are regioisomers in the context of pyrazole synthesis, and why is their selective formation so critical?

A1: In the synthesis of pyrazoles from unsymmetrical 1,3-dicarbonyl compounds and substituted hydrazines, regioisomers are structural isomers that arise from the two possible orientations of the hydrazine addition to the dicarbonyl. For instance, the reaction of 1-phenyl-1,3-butanedione with methylhydrazine can yield either 1,5-dimethyl-3-phenyl-1H-pyrazole or 1,3-dimethyl-5-phenyl-1H-pyrazole.^[3] Controlling the reaction to produce a single, desired regioisomer is crucial because different regioisomers can possess vastly different biological activities and physicochemical properties.^{[3][4]} For therapeutic applications, a single, pure regioisomer is often a regulatory requirement.

Q2: What are the primary factors that dictate the regioselectivity in the Knorr synthesis of pyrazoles?

A2: The regioselectivity of the Knorr pyrazole synthesis, the reaction between a 1,3-dicarbonyl compound and a hydrazine, is governed by a combination of factors:^{[3][5]}

- **Electronic Effects:** The electrophilicity of the two carbonyl carbons is a major determinant. Electron-withdrawing groups enhance the electrophilicity of a carbonyl carbon, making it more susceptible to the initial nucleophilic attack by the hydrazine.^{[3][4]}
- **Steric Hindrance:** Bulky substituents on the 1,3-dicarbonyl compound or the hydrazine can direct the initial nucleophilic attack to the less sterically hindered carbonyl group.^{[3][4]}
- **Reaction Conditions:** The choice of solvent, temperature, and the presence of acid or base catalysts can significantly influence the reaction pathway and, consequently, the regiochemical outcome.^{[3][6]}

Q3: How can the choice of solvent dramatically influence the regioselectivity of my pyrazole synthesis?

A3: The solvent can play a pivotal role in controlling which regioisomer is formed. For example, the use of fluorinated alcohols like 2,2,2-trifluoroethanol (TFE) or 1,1,1,3,3,3-hexafluoro-2-propanol (HFIP) has been shown to significantly increase the regioselectivity in the formation of N-methylpyrazoles from 1,3-diketones and methylhydrazine, often resulting in a single detectable regioisomer.[7][8] This is in stark contrast to conventional solvents like ethanol, which often yield mixtures of regioisomers.[7][8]

Q4: How do I definitively determine the regiochemistry of my synthesized pyrazoles?

A4: Unambiguous characterization of regioisomers is most reliably achieved using Nuclear Magnetic Resonance (NMR) spectroscopy.[9]

- ^1H and ^{13}C NMR: These standard techniques provide initial structural information, as the chemical shifts of the protons and carbons on the pyrazole ring and its substituents will differ between the two isomers.[9]
- 2D NMR (NOESY): The Nuclear Overhauser Effect Spectroscopy (NOESY) experiment is the definitive method for assigning regiochemistry.[9] This technique detects through-space proximity between protons. A cross-peak between the N-substituent (e.g., N-CH₃) and a proton on a C-substituent (e.g., C5-Aryl) confirms their spatial closeness, thus unequivocally identifying the isomer.[9]

Troubleshooting Guide

Issue 1: My reaction is producing a nearly 1:1 mixture of regioisomers.

Problem: The electronic and steric differentiation between the two carbonyl groups of your 1,3-dicarbonyl substrate is insufficient under the current reaction conditions to favor the formation of one regioisomer.

Troubleshooting Strategies:

- Solvent Modification: As a primary step, consider switching to a fluorinated alcohol solvent such as 2,2,2-trifluoroethanol (TFE).[3] These solvents can enhance regioselectivity through their unique hydrogen-bonding properties.[9]

- **Temperature Adjustment:** Lowering the reaction temperature can enhance kinetic control, potentially favoring the formation of one regioisomer over the other.[3]
- **Catalyst Screening:** The addition of an acid or base catalyst can alter the reaction pathway. Experiment with both acidic (e.g., acetic acid, p-toluenesulfonic acid) and basic (e.g., sodium acetate) conditions to see if regioselectivity is improved.[9]

Issue 2: The major product of my reaction is the undesired regioisomer.

Problem: The inherent electronic and steric properties of your starting materials favor the formation of the unwanted isomer under your current experimental setup.

Troubleshooting Strategies:

- **Re-evaluate Starting Material Design:**
 - **Electronic Tuning:** If possible, modify the substituents on the 1,3-dicarbonyl. A stronger electron-withdrawing group can be used to direct the initial attack to the more electrophilic carbonyl.
 - **Steric Tuning:** Introducing a bulkier substituent near one of the carbonyl groups can sterically shield it, directing the hydrazine to the less hindered carbonyl.
- **Protecting Group Strategy:** In some instances, a protecting group can be employed to temporarily block one of the reactive sites, thereby directing the reaction towards the desired outcome.[3]
- **Alternative Synthetic Routes:** Consider alternative, more regioselective methods for pyrazole synthesis, such as 1,3-dipolar cycloadditions or direct substitution on a pre-formed pyrazole ring.[1][2]

Issue 3: I have already synthesized a mixture of regioisomers and need to separate them.

Problem: A mixture of pyrazole regioisomers has been formed, and a pure sample of one isomer is required for subsequent applications.

Troubleshooting Strategies:

- **Column Chromatography:** This is the most common method for separating regioisomers. Careful optimization of the solvent system (eluent) is key. Start with a non-polar solvent system and gradually increase the polarity. Thin-layer chromatography (TLC) should be used to determine the optimal solvent system for separation.[3]
- **Recrystallization:** If the regioisomers have different solubilities in a particular solvent, fractional recrystallization can be a highly effective purification method.[3] Experiment with a range of solvents to find one that preferentially crystallizes the desired isomer.[3]

Data Presentation: Impact of Reaction Conditions on Regioselectivity

Table 1: Effect of Solvent on the Regioselectivity of Pyrazole Formation

1,3-Dicarbonyl Substrate	Hydrazine	Solvent	Regioisomeric Ratio (A:B)	Reference
1-(4-chlorophenyl)-4,4,4-trifluorobutane-1,3-dione	Phenylhydrazine	Ethanol	1:1	[10]
1-(4-chlorophenyl)-4,4,4-trifluorobutane-1,3-dione	Phenylhydrazine	N,N-Dimethylacetamide	98:2	[10]
1-phenyl-1,3-butanedione	Methylhydrazine	Ethanol	Mixture	[7]
1-phenyl-1,3-butanedione	Methylhydrazine	TFE	Single Isomer	[7]

Regioisomer A is the 3-trifluoromethyl derivative and B is the 5-trifluoromethyl derivative. Data adapted from studies on the effect of fluorinated alcohols and other solvents on pyrazole formation.[3][10]

Table 2: Influence of Hydrazine Substituent on Regioselectivity

Acetylenic Ketone	Hydrazine	Regioisomeric Ratio (A:B)	Reference
1-phenylprop-2-yn-1-one	Methylhydrazine	93:7 to 97:3	[10]
1-phenylprop-2-yn-1-one	Phenylhydrazine	13:87 to 1:99	[10]

Data from a study on the cyclocondensation of acetylenic ketones with hydrazines, highlighting how the electronic nature of the hydrazine substituent can reverse the regioselectivity.[10]

Experimental Protocols

Protocol 1: General Procedure for Regioselective Pyrazole Synthesis using Fluorinated Alcohols

This protocol is a general guideline and may require optimization for specific substrates.

- **Dissolution:** Dissolve the 1,3-dicarbonyl compound (1.0 mmol) in 2,2,2-trifluoroethanol (TFE) (5 mL).[3]
- **Addition:** Add the substituted hydrazine (1.1 mmol) to the solution at room temperature.[3]
- **Reaction Monitoring:** Stir the reaction mixture at room temperature and monitor its progress by thin-layer chromatography (TLC).
- **Work-up:** Once the reaction is complete, remove the solvent under reduced pressure. Dissolve the residue in a suitable organic solvent (e.g., ethyl acetate) and wash with water and brine.

- Purification: Dry the organic layer over anhydrous sodium sulfate, filter, and concentrate under reduced pressure. Purify the crude product by flash column chromatography on silica gel to isolate the desired regioisomer.

Visualization of Reaction Mechanisms

Knorr Pyrazole Synthesis: The Origin of Regioisomers

The following diagram illustrates the two competing pathways in the Knorr pyrazole synthesis with an unsymmetrical 1,3-dicarbonyl, leading to the formation of two distinct regioisomers. The initial nucleophilic attack of the hydrazine at either carbonyl C1 or C2 determines the final substitution pattern on the pyrazole ring.

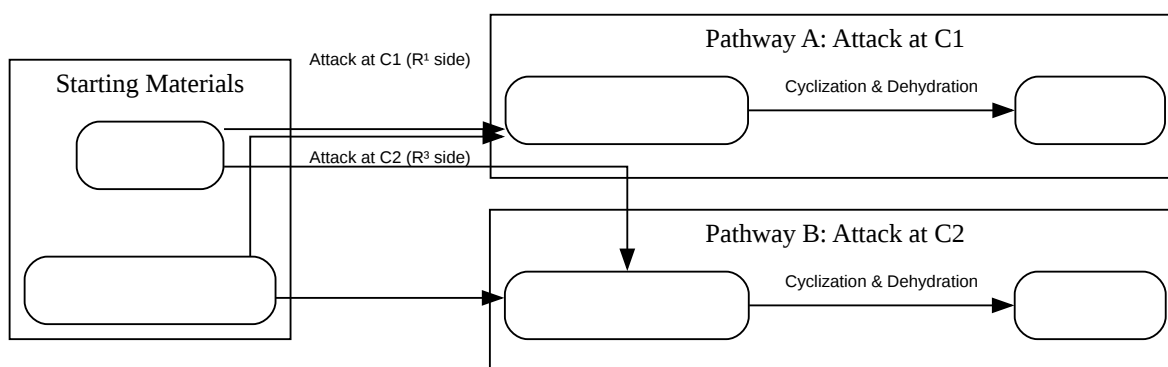

[Click to download full resolution via product page](#)

Caption: Competing pathways in the Knorr pyrazole synthesis.

Troubleshooting Workflow for Poor Regioselectivity

This flowchart provides a logical sequence of steps to troubleshoot and optimize reactions that yield unsatisfactory regioselectivity.

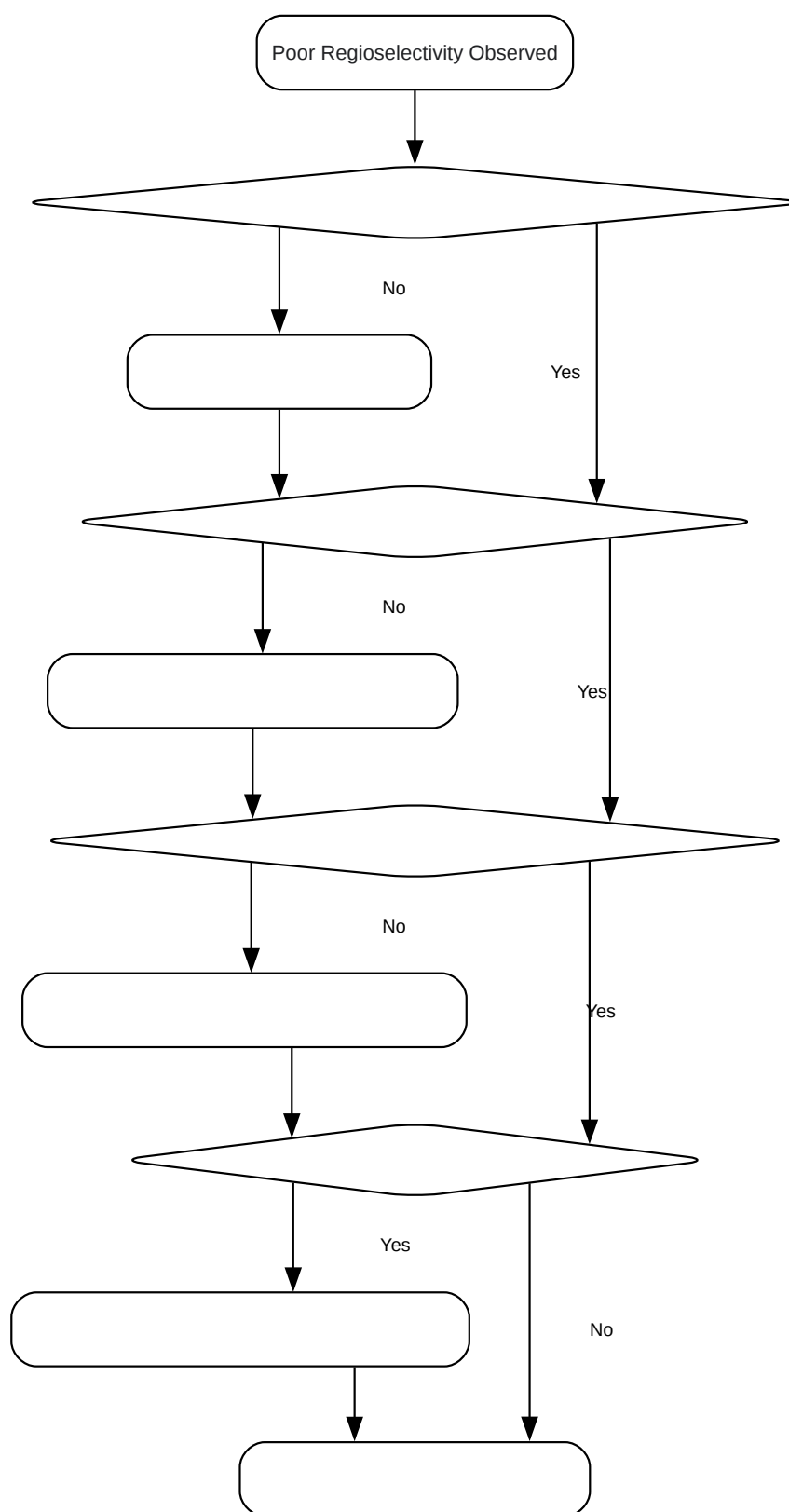

[Click to download full resolution via product page](#)

Caption: Troubleshooting workflow for poor regioselectivity.

References

- Yoon, J. Y., Lee, S. G., & Shin, H. (2011). Recent Advances in the Regioselective Synthesis of Pyrazoles. *Current Organic Chemistry*, 15(5), 657-674. [[Link](#)]
- BenchChem. (2025). Technical Support Center: Managing Regioselectivity in Substituted Pyrazole Synthesis. BenchChem.
- BenchChem. (2025).
- BenchChem. (2025). Knorr Pyrazole Synthesis: A Detailed Protocol for the Preparation of Substituted Pyrazoles. BenchChem.
- Fustero, S., Román, R., Sanz-Cervera, J. F., Simón-Fuentes, A., Cuñat, A. C., Villanova, S., & Murguía, M. (2008). Improved regioselectivity in pyrazole formation through the use of fluorinated alcohols as solvents: synthesis and biological activity of fluorinated tebufenpyrad analogs. *The Journal of organic chemistry*, 73(9), 3523–3529. [[Link](#)]
- Elguero, J., Goya, P., Jagerovic, N., & Silva, A. M. (2010). Pyrazoles as drugs: facts and fantasies. In *Targets in Heterocyclic Systems* (Vol. 14, pp. 52-98). Italian Chemical Society.
- Fustero, S., Román, R., Sanz-Cervera, J. F., Simón-Fuentes, A., Cuñat, A. C., & Murguía, M. (2008). Improved Regioselectivity in Pyrazole Formation through the Use of Fluorinated Alcohols as Solvents: Synthesis and Biological Activity of Fluorinated Tebufenpyrad Analogs. *The Journal of Organic Chemistry*, 73(9), 3523-3529.
- Power, M. O., O'Brien, J. E., & Moody, T. S. (2022). Discovery of unexpectedly complex reaction pathways for the Knorr pyrazole synthesis via transient flow. *Reaction Chemistry & Engineering*, 7(10), 2235-2241. [[Link](#)]
- Shawali, A. S., & Abdallah, M. A. (2013). Regioselective synthesis of some functionalized 3,4'-bis-(pyrazolyl)ketones and chemoselectivity in their reaction with hydrazine hydrate. *European Journal of Chemistry*, 4(2), 149-155.
- Yoon, J. Y., Lee, S. G., & Shin, H. (2011). Recent advances in the regioselective synthesis of Pyrazoles. *Current Organic Chemistry*, 15(5), 657-674.
- Bakulev, V. A., Karimov, D. N., & Eltsov, O. S. (2025). Switching N-Alkylation Regioselectivity of Trifluoromethylated Pyrazoles Guided by Functional Group Tuning. *Molecules*, 30(21), 5038.
- BenchChem. (2025). Technical Support Center: Regioselective Synthesis of Substituted Pyrazoles. BenchChem.

- Park, Y. J., & Lee, Y. R. (2000). Regioselective Synthesis of Unsymmetrical 3,5-Dialkyl-1-arylpyrazoles. *Organic Letters*, 2(19), 2947-2950.
- Panda, N., & Jena, A. K. (2012). Ce-catalyzed regioselective synthesis of pyrazoles from 1,2-diols via tandem oxidation and C–C/C–N bond formation. *Organic & Biomolecular Chemistry*, 10(45), 9069-9072.
- Wang, L., Huang, J., Gong, X., & Wang, J. (2013). Highly regioselective organocatalyzed synthesis of pyrazoles from diazoacetates and carbonyl compounds. *Chemistry (Weinheim an der Bergstrasse, Germany)*, 19(23), 7555–7560.
- Shawali, A. S., & Abdallah, M. A. (2012). Site-Selectivity in the reaction of hydrazine hydrate with 3,4'-Bis-(functionalized carbonyl). *Arkivoc*, 2012(5), 301-311.
- Sharma, V., Kumar, V., & Singh, P. (2023). Recent Advances in the Synthesis of Pyrazole Derivatives: A Review. *Molecules*, 28(18), 6537.
- Organic Chemistry Portal. (n.d.). Pyrazole synthesis. [[Link](#)]
- Thieme Chemistry. (n.d.). Regioselective Synthesis of 3,5-Disubstituted Pyrazoles. [[Link](#)]
- Gosselin, F., O'Shea, P. D., Webster, R. A., Reamer, R. A., Tillyer, R. D., & Grabowski, E. J. (2006). Highly Regioselective Synthesis of 1-Aryl-3,4,5-Substituted Pyrazoles. *Synlett*, 2006(19), 3267-3270.
- Wang, X., Zhu, J., & Zhang, Y. (2018). Regio- and Stereoselective Switchable Synthesis of (E)- and (Z)
- J&K Scientific LLC. (2026, February 23). Knorr Pyrazole Synthesis.
- IntechOpen. (2022, November 23).
- Zhang, Z., Li, R. P., Gong, X., Xu, X., Peng, X., & Tang, S. (2025). Regioselective Pyrazole Synthesis via Base-Mediated [3+2] Cycloaddition of 2-Alkynyl-1,3-Dithianes and Sydnone. *The Journal of Organic Chemistry*, 90(6), 3769–3778.
- El-Faham, A., & Al-Othman, Z. A. (2021). Substituted Pyrazoles and Their Heteroannulated Analogs—Recent Syntheses and Biological Activities. *Molecules*, 26(16), 4995.

Need Custom Synthesis?

BenchChem offers custom synthesis for rare earth carbides and specific isotopic labeling.

Email: info@benchchem.com or [Request Quote Online](#).

Sources

- [1. benthamdirect.com](https://benthamdirect.com) [benthamdirect.com]
- [2. pure.ewha.ac.kr](https://pure.ewha.ac.kr) [pure.ewha.ac.kr]
- [3. pdf.benchchem.com](https://pdf.benchchem.com) [pdf.benchchem.com]
- [4. pdf.benchchem.com](https://pdf.benchchem.com) [pdf.benchchem.com]
- [5. pdf.benchchem.com](https://pdf.benchchem.com) [pdf.benchchem.com]
- [6. Discovery of unexpectedly complex reaction pathways for the Knorr pyrazole synthesis via transient flow - Reaction Chemistry & Engineering \(RSC Publishing\)](#)
[DOI:10.1039/D2RE00271J](https://doi.org/10.1039/D2RE00271J) [pubs.rsc.org]
- [7. Improved regioselectivity in pyrazole formation through the use of fluorinated alcohols as solvents: synthesis and biological activity of fluorinated tebufenpyrad analogs - PubMed](#)
[pubmed.ncbi.nlm.nih.gov]
- [8. researchgate.net](https://researchgate.net) [researchgate.net]
- [9. pdf.benchchem.com](https://pdf.benchchem.com) [pdf.benchchem.com]
- [10. Synthesis and Pharmacological Activities of Pyrazole Derivatives: A Review - PMC](#)
[pmc.ncbi.nlm.nih.gov]
- To cite this document: BenchChem. [Technical Support Center: Controlling Regioselectivity in the Synthesis of Unsymmetrical Pyrazoles]. BenchChem, [2026]. [Online PDF]. Available at: [<https://www.benchchem.com/product/b2618547/docs#technical-support-center-controlling-regioselectivity-in-the-synthesis-of-unsymmetrical-pyrazoles>]

Disclaimer & Data Validity:

The information provided in this document is for Research Use Only (RUO) and is strictly not intended for diagnostic or therapeutic procedures. While BenchChem strives to provide accurate protocols, we make no warranties, express or implied, regarding the fitness of this product for every specific experimental setup.

Technical Support: The protocols provided are for reference purposes. Unsure if this reagent suits your experiment?

Need Industrial/Bulk Grade? [Request Custom Synthesis Quote](#)

BenchChem

Our mission is to be the trusted global source of essential and advanced chemicals, empowering scientists and researchers to drive progress in science and industry.

Contact

Address: 3281 E Guasti Rd

Ontario, CA 91761, United States

Phone: (601) 213-4426

Email: info@benchchem.com

[Contact our Ph.D. Support Team for a compatibility check](#)