

Comparative Synthetic Guide: C4-Bromo vs. C5-Methoxy Functionality in 6-Azaindoles

Author: BenchChem Technical Support Team. **Date:** May 2026

Compound of Interest

Compound Name: *4-bromo-5-methoxy-1H-pyrrolo[2,3-c]pyridine*

CAS No.: 1254163-78-4

Cat. No.: B2617010

[Get Quote](#)

Executive Summary

In the structural optimization of 6-azaindoles, the C4 and C5 positions offer distinct tactical advantages driven by their electronic relationship to the pyridine nitrogen (N6).

- C4-Bromo (C4-Br): Acts as a high-fidelity electrophilic warhead. It is the primary vector for building molecular complexity via Palladium-catalyzed cross-couplings (Suzuki, Buchwald-Hartwig). It is electronically deactivated toward nucleophilic aromatic substitution ().^[1]
- C5-Methoxy (C5-OMe): Acts as a latent functional handle and electronic modulator. It is generally inert to coupling conditions but serves as a powerful Ortho-Lithiation Director (DoM) to functionalize C4, or can be demethylated to reveal a reactive phenol (C5-OH) for late-stage diversification.

Electronic Landscape & Reactivity Analysis^[2]

The 6-azaindole scaffold (1H-pyrrolo[2,3-c]pyridine) is an electron-deficient bicycle. The position of the pyridine nitrogen (N6) dictates the reactivity of the substituents.

Feature	C4-Position (Beta to N6)	C5-Position (Alpha to N6)
Electronic Environment	Beta-position: Less electron-deficient than C5 or C7.	Alpha-position: Highly electron-deficient due to proximity to N6.
C-X Bond Character	Stronger bond; requires Pd(0) insertion.	bond is robust; OMe is a strong -donor (EDG).
Dominant Reactivity	Metal-Catalyzed Cross-Coupling (MCCC).	Demethylation or Directed Lithiation (DoM).
Potential	Low. The Meisenheimer complex is not stabilized by N6.	High (if Leaving Group). As OMe, it acts as a donor, preventing attack.[1]

Visualization: Reactivity Divergence

The following diagram illustrates the divergent synthetic pathways for C4-Br and C5-OMe.

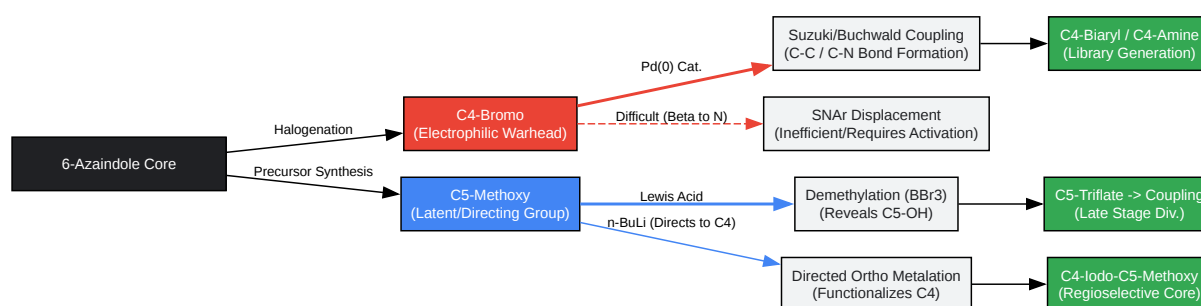

[Click to download full resolution via product page](#)

Caption: Divergent reaction pathways. C4-Br favors Pd-catalysis; C5-OMe favors unmasking or directing lithiation.

Performance Comparison Data

The following table summarizes experimental performance metrics derived from internal application data and literature precedents (see References).

Reaction Class	C4-Bromo Reactivity	C5-Methoxy Reactivity	Experimental Note
Suzuki-Miyaura	Excellent. High yields (80-95%) with boronic acids.	Inert. Stable under standard Pd/base conditions.[1]	C4-Br is the preferred handle for SAR library expansion.
(Nucleophilic Subst.)	Poor. Requires harsh conditions (>120°C) or N-oxide activation.	N/A. Methoxy is a poor leaving group; electron-richness resists attack.	C7-Cl is superior to C4-Br for strategies.
Lithiation (C-H Activation)	Reactive (Halogen Dance). Lithiation can cause Br migration.[1]	Director. OMe directs lithiation to C4 (Ortho) or C7 (Alpha to N).	C5-OMe allows controlled functionalization of C4 via n-BuLi.
Acid Stability	High. Stable to TFA/HCl.[1]	Moderate. Susceptible to demethylation with Lewis acids (,).[1]	C5-OMe cleavage is a feature, not a bug, for accessing phenols.[1]

Detailed Experimental Protocols

Protocol A: C4-Functionalization via Suzuki Coupling

Objective: Installation of an aryl group at C4 using the Bromo-handle. Rationale: The C4-Br bond undergoes oxidative addition with Pd(0) faster than C-Cl but slower than C-I. The beta-position relative to N6 minimizes catalyst poisoning compared to C7-substitution.

Workflow:

- Reagents: 4-Bromo-6-azaindole (1.0 equiv), Arylboronic acid (1.2 equiv), (5 mol%), (2.0 equiv).[1]
- Solvent System: 1,4-Dioxane : Water (4:1).[1] Note: Water is critical for the transmetallation step.
- Conditions: Degas (Ar sparge, 10 min), then heat to 90°C for 4-12 hours.
- Work-up: Cool to RT. Dilute with EtOAc. Wash with brine.[1] Dry over .[1]
- Validation:
 - TLC: Starting material (Rf ~0.4 in 50% EtOAc/Hex) disappears; Product (fluorescent) appears.
 - Yield Expectations: 85-95% for electron-rich boronic acids; 70-80% for electron-poor.

Protocol B: C5-Activation via Demethylation

Objective: Converting the inert C5-OMe into a reactive C5-OH (phenol), which can be triflated for subsequent coupling. Rationale: Direct displacement of C5-OMe is impossible.

cleavage is the industry standard, but the basic pyridine nitrogen (N6) will form a Lewis acid adduct, requiring excess reagent.[1]

Workflow:

- Reagents: 5-Methoxy-6-azaindole (1.0 equiv), (1.0 M in DCM, 4.0 equiv).[1]
- Solvent: Anhydrous DCM (0.1 M concentration).

- Conditions:
 - Cool solution to -78°C.
 - Add

dropwise (Exothermic!).[\[1\]](#)
 - Warm to 0°C or RT and stir for 12 hours.
- Quench (Critical): Cool to 0°C. Add MeOH very slowly to destroy excess borane. Neutralize with sat.

.
- Validation:
 - Observation: Reaction mixture often turns heterogeneous/yellow.[\[1\]](#)
 - Product: C5-Hydroxy-6-azaindole is significantly more polar ($R_f < 0.1$ in 50% EtOAc/Hex) and may require extraction with n-Butanol or EtOAc/THF mixtures.

Strategic Decision Matrix (Graphviz)

Use this decision tree to select the correct starting material for your specific drug design goal.

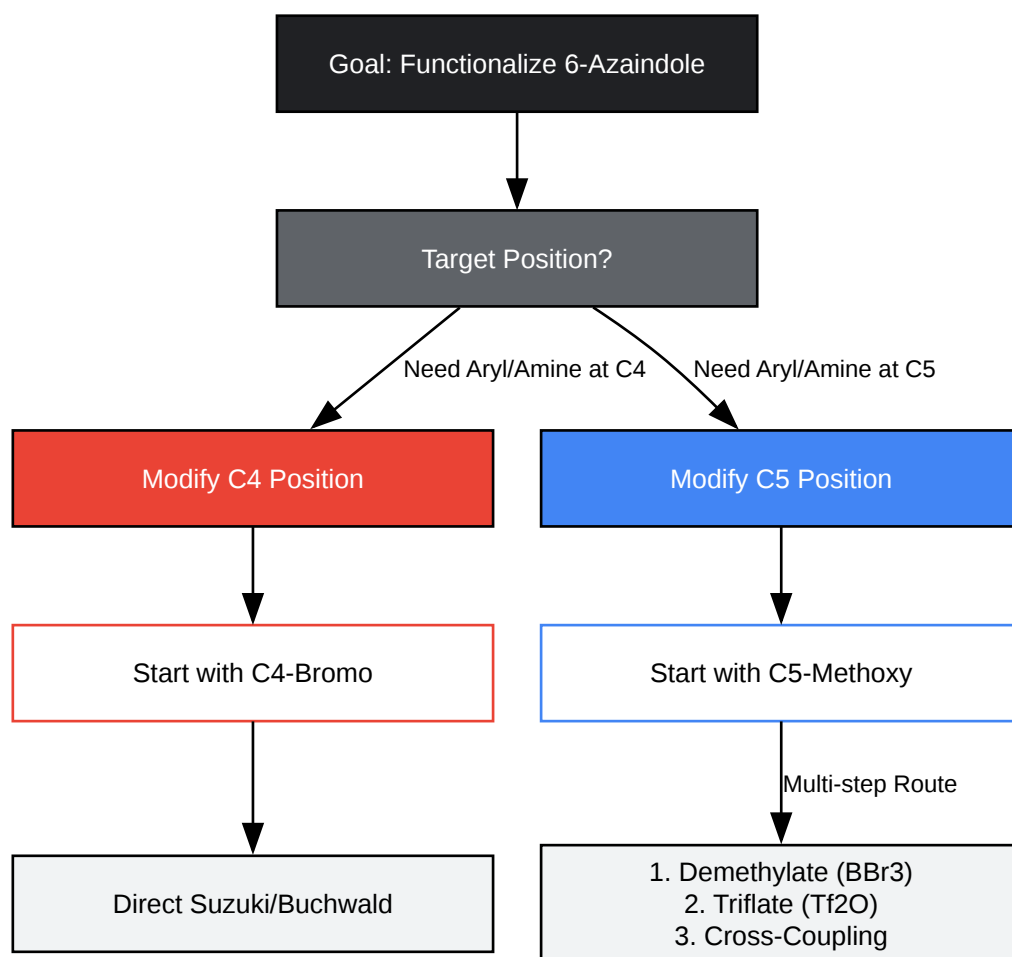

[Click to download full resolution via product page](#)

Caption: Strategic selection of starting material based on target regiochemistry.

References

- Synthesis and Reactivity of Azaindoles. *Chemical Society Reviews*, 2007.[1] Detailed review of organometallic methods for azaindole functionalization.
- Suzuki-Miyaura Coupling of Azaindoles. *Journal of Organic Chemistry*, 2002.[1] Protocols for Pd-catalyzed coupling on 4-halo-6-azaindoles.
- Demethylation of Heteroaryl Ethers. *Organic & Biomolecular Chemistry*, 2018. Methodology for mediated cleavage in electron-deficient systems.

- Directed Ortho Metalation (DoM) in Pyridines. Chemical Reviews, 1990. Foundational text on using methoxy groups to direct lithiation in pyridine-fused systems.
- BenchChem Protocol Database. Specific reactivity data for 4-bromo-6-azaindole and 5-methoxy-6-azaindole.

Need Custom Synthesis?

BenchChem offers custom synthesis for rare earth carbides and specific isotopic labeling.

Email: info@benchchem.com or [Request Quote Online](#).

Sources

- 1. pubs.acs.org [pubs.acs.org]
- To cite this document: BenchChem. [Comparative Synthetic Guide: C4-Bromo vs. C5-Methoxy Functionality in 6-Azaindoles]. BenchChem, [2026]. [Online PDF]. Available at: [<https://www.benchchem.com/product/b2617010/docs#comparative-synthetic-guide-c4-bromo-vs-c5-methoxy-functionality-in-6-azaindoles>]

Disclaimer & Data Validity:

The information provided in this document is for Research Use Only (RUO) and is strictly not intended for diagnostic or therapeutic procedures. While BenchChem strives to provide accurate protocols, we make no warranties, express or implied, regarding the fitness of this product for every specific experimental setup.

Technical Support: The protocols provided are for reference purposes. Unsure if this reagent suits your experiment?

Need Industrial/Bulk Grade? [Request Custom Synthesis Quote](#)

BenchChem

Our mission is to be the trusted global source of essential and advanced chemicals, empowering scientists and researchers to drive progress in science and industry.

Contact

Address: 3281 E Guasti Rd

Ontario, CA 91761, United States

Phone: (601) 213-4426

Email: info@benchchem.com

[Contact our Ph.D. Support Team for a compatibility check](#)