

Technical Comparison Guide: Mass Spectrometry Profiling of 2-(2-Bromophenoxy)pyrazine

Author: BenchChem Technical Support Team. **Date:** May 2026

Compound of Interest

Compound Name: 2-(2-Bromophenoxy)pyrazine

CAS No.: 129242-46-2

Cat. No.: B2615259

[Get Quote](#)

Executive Summary

2-(2-Bromophenoxy)pyrazine is a critical heterocyclic building block, often utilized in the synthesis of bioactive kinase inhibitors and GLP-1 agonists. Its structural duality—combining an electron-deficient pyrazine ring with an electron-rich, halogenated phenoxy group—presents unique challenges in mass spectrometry (MS) characterization.

This guide provides a comparative technical analysis of Electron Ionization (EI) versus Electrospray Ionization (ESI) workflows for this compound. Unlike generic templates, this document focuses on the specific fragmentation dynamics driven by the ortho-bromine substituent and the ether linkage, providing a self-validating framework for structural elucidation and impurity profiling.

Structural Analysis & Isotope Signature

Before selecting an ionization method, the analyst must validate the precursor ion identity through its isotopic envelope. The presence of a single bromine atom imparts a distinct

"doublet" signature.

Theoretical Precursor Ions

Ionization Mode	Species	Formula	m/z (Monoisotopic ⁷⁹ Br)	m/z (Isotopic ⁸¹ Br)	Ratio
EI (GC-MS)	M ^{+•}	C ₁₀ H ₇ BrN ₂ O	249.97	251.97	1:1
ESI (LC-MS)	[M+H] ⁺	C ₁₀ H ₈ BrN ₂ O ⁺	250.98	252.98	1:1

Critical Validation Step: In any spectrum, the two primary peaks must exhibit a near-perfect 1:1 intensity ratio. A deviation >10% suggests interference or co-elution.

Comparative Analysis: EI vs. ESI Performance

The choice between EI and ESI is not merely about instrumentation availability; it dictates the depth of structural information obtained.

Performance Matrix

Feature	Electron Ionization (EI)	Electrospray Ionization (ESI)
Energy Regime	Hard (~70 eV)	Soft (Thermal/Voltage)
Primary Utility	Structural Fingerprinting & Library Matching	Quantitation & Biological Matrix Analysis
Molecular Ion	M ⁺ [1][2] [•] (Often weak due to ether cleavage)	[M+H] ⁺ (Dominant base peak)
Fragmentation	Spontaneous, extensive (In-source)	Controlled (Collision Induced Dissociation - CID)
Key Mechanism	Radical-site initiated cleavage	Charge-remote & Charge-proximal cleavage
Limit of Detection	Nanogram range	Picogram/Femtogram range

Scientist's Recommendation:

- Use EI (GC-MS) during the synthesis optimization phase to identify isomeric impurities (e.g., 3-bromo vs. 2-bromo isomers) which often have distinct retention times and fragmentation ratios.
- Use ESI (LC-MS/MS) for DMPK studies where sensitivity is paramount and the molecule is likely dissolved in biological fluids.

Fragmentation Dynamics & Mechanisms[3]

This section details the specific bond-breaking events. The fragmentation of **2-(2-Bromophenoxy)pyrazine** is governed by the lability of the ether C-O bond and the stability of the aromatic radical cations.

Fragmentation Pathway Diagram

The following diagram illustrates the competing pathways observed under Collision Induced Dissociation (CID).

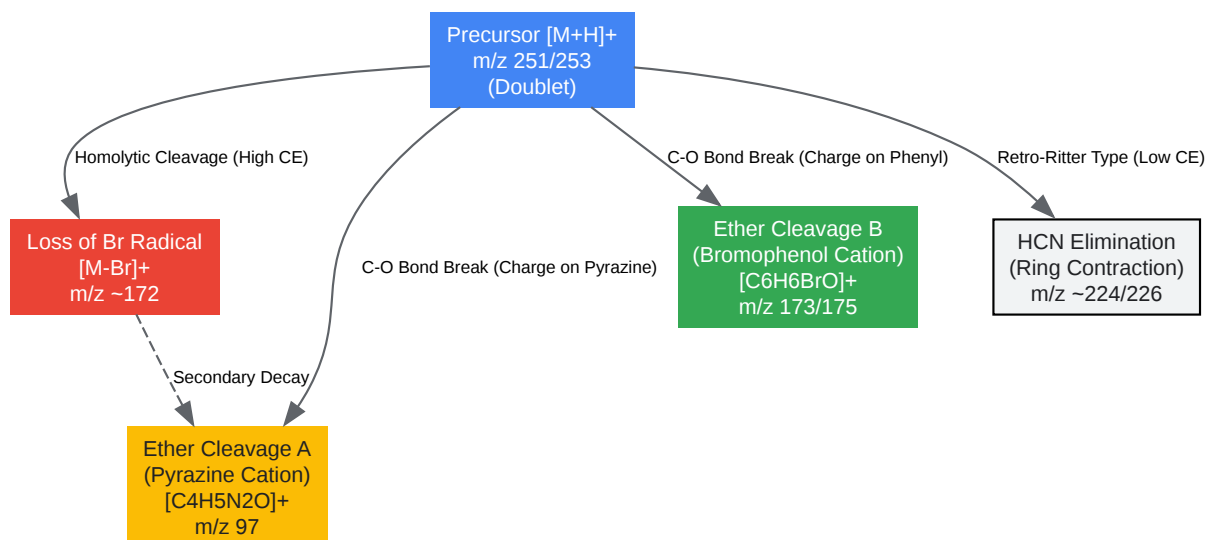

[Click to download full resolution via product page](#)

Figure 1: Predicted fragmentation tree for **2-(2-Bromophenoxy)pyrazine** under ESI-CID conditions.

Mechanistic Deep Dive

Pathway A: Ether Linkage Cleavage (Dominant)

The ether oxygen acts as the pivot point. Under CID, the C-O bond is the weakest link.

- Mechanism: Protonation likely occurs on the pyrazine nitrogen (most basic site). However, during collision, the energy transfer causes inductive cleavage at the ether oxygen.
- Result: This yields a pyrazin-2-ol type fragment ($m/z \sim 97$) or, if the charge migrates, a bromophenol cation ($m/z 173/175$).
- Diagnostic Value: High. Confirms the presence of both ring systems.

Pathway B: Radical Bromine Loss

- Mechanism: Homolytic cleavage of the C-Br bond.
- Observation: Loss of 79/81 Da.
- Result: Appearance of a peak at $[M+H - Br]^+$ ($m/z \sim 172$).
- Note: This pathway is more prevalent in EI than ESI, but occurs in ESI at higher collision energies (>35 eV).

Pathway C: Pyrazine Ring Collapse

- Mechanism: Pyrazines are known to lose neutral HCN (27 Da) or C_2H_2N (40 Da) via retro-cyclization.
- Observation: A shift of -27 Da from the parent ion.
- Diagnostic Value: Specific to the nitrogenous heterocycle.

Experimental Protocol: Validated ESI-MS/MS

Workflow

To reproduce these results, follow this self-validating protocol designed for a Triple Quadrupole (QQQ) system.

Method Parameters[4]

Parameter	Setting	Rationale
Ionization Source	ESI Positive (+)	Pyrazine nitrogens protonate readily.
Spray Voltage	3.5 - 4.0 kV	Optimal for small molecule ionization without discharge.
Mobile Phase	A: 0.1% Formic Acid (H ₂ O)B: Acetonitrile	Formic acid ensures protonation ([M+H] ⁺).
Flow Rate	0.4 mL/min	Standard flow for stable electrospray.
Collision Gas	Argon or Nitrogen	Argon provides more efficient fragmentation (heavier).

Step-by-Step Optimization Workflow

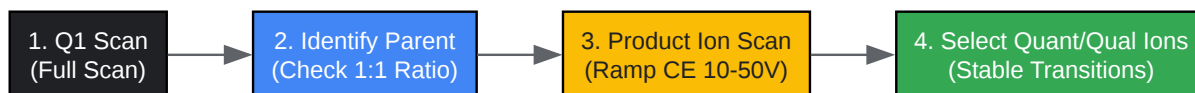

[Click to download full resolution via product page](#)

Figure 2: Workflow for optimizing the MS/MS transitions.

Protocol Steps:

- Infusion: Direct infuse a 1 µg/mL standard solution at 10 µL/min.
- Q1 Scan: Scan range m/z 100–400. Locate the doublet at 251/253.
- Isotope Check: If the 253 peak is <90% or >110% of the 251 peak height, check for contamination.
- Product Ion Scan: Select m/z 251 (⁷⁹Br isotope) as the precursor. Ramp Collision Energy (CE) from 10V to 50V.

- Selection:
 - Quantifier: Choose the most intense stable fragment (likely m/z 97 or 173).
 - Qualifier: Choose the second most intense fragment to calculate the ion ratio for confirmation.

References

- Silverstein, R. M., Webster, F. X., & Kiemle, D. J. (2005). Spectrometric Identification of Organic Compounds. 7th Edition. John Wiley & Sons.
- NIST Mass Spectrometry Data Center. Pyrazine Fragmentation Patterns. National Institute of Standards and Technology. Available at: [\[Link\]](#)
- McLafferty, F. W., & Turecek, F. (1993). Interpretation of Mass Spectra. 4th Edition. University Science Books. (Authoritative source on odd-electron vs.
- PubChem Compound Summary. **2-(2-Bromophenoxy)pyrazine**. National Center for Biotechnology Information. Available at: [\[Link\]](#)

Need Custom Synthesis?

BenchChem offers custom synthesis for rare earth carbides and specific isotopic labeling.

Email: info@benchchem.com or [Request Quote Online](#).

Sources

- [1. An Organic Chemist's Guide to Electrospray Mass Spectrometric Structure Elucidation - PMC \[pmc.ncbi.nlm.nih.gov\]](#)
- [2. A tutorial in small molecule identification via electrospray ionization-mass spectrometry: The practical art of structural elucidation - PMC \[pmc.ncbi.nlm.nih.gov\]](#)
- To cite this document: BenchChem. [Technical Comparison Guide: Mass Spectrometry Profiling of 2-(2-Bromophenoxy)pyrazine]. BenchChem, [2026]. [Online PDF]. Available at: [\[https://www.benchchem.com/product/b2615259/docs#technical-comparison-guide-mass-spectrometry-profiling-of-2-2-bromophenoxy-pyrazine\]](https://www.benchchem.com/product/b2615259/docs#technical-comparison-guide-mass-spectrometry-profiling-of-2-2-bromophenoxy-pyrazine)

Disclaimer & Data Validity:

The information provided in this document is for Research Use Only (RUO) and is strictly not intended for diagnostic or therapeutic procedures. While BenchChem strives to provide accurate protocols, we make no warranties, express or implied, regarding the fitness of this product for every specific experimental setup.

Technical Support: The protocols provided are for reference purposes. Unsure if this reagent suits your experiment?

Need Industrial/Bulk Grade? [Request Custom Synthesis Quote](#)

BenchChem

Our mission is to be the trusted global source of essential and advanced chemicals, empowering scientists and researchers to drive progress in science and industry.

Contact

Address: 3281 E Guasti Rd
Ontario, CA 91761, United States
Phone: (601) 213-4426
Email: info@benchchem.com

[Contact our Ph.D. Support Team for a compatibility check](#)