

Technical Support Center: Optimization of Reaction Conditions for Nitrile Oxide Cycloadditions

Author: BenchChem Technical Support Team. **Date:** March 2026

Compound of Interest

Compound Name:	4,5-dihydro-1,2-oxazole-3-carbonitrile
CAS No.:	65150-73-4
Cat. No.:	B2610386

[Get Quote](#)

Welcome to the technical support center for nitrile oxide cycloadditions. This guide is designed for researchers, scientists, and drug development professionals to provide in-depth, practical advice for optimizing these powerful synthetic reactions. Here, you will find troubleshooting guides and frequently asked questions (FAQs) formatted to directly address the specific challenges you may encounter during your experiments.

Introduction to Nitrile Oxide Cycloadditions

The 1,3-dipolar cycloaddition of nitrile oxides with alkenes or alkynes is a cornerstone of heterocyclic chemistry, providing a direct route to valuable isoxazolines and isoxazoles.^{[1][2][3]} These heterocycles are not only prevalent in a wide array of natural products and biologically active compounds but also serve as versatile synthetic intermediates.^{[1][2][4][5]} For instance, the isoxazoline ring can be considered a masked equivalent of a β -hydroxy ketone or a γ -amino alcohol, unlocking diverse synthetic pathways.^[6]

Despite their utility, nitrile oxide cycloadditions can be sensitive to reaction conditions, and achieving optimal yields and selectivities often requires careful tuning of various parameters. This guide will walk you through the most common challenges and provide evidence-based solutions to streamline your research.

Frequently Asked Questions (FAQs)

Q1: My reaction is not working, or the yield is very low. What are the first things I should check?

A1: Low or no yield is a common issue that can often be traced back to a few key factors:

- **Nitrile Oxide Generation:** Nitrile oxides are often highly reactive and unstable, making their in situ generation a preferred strategy.^[7] Verify the purity of your precursor (e.g., aldoxime, nitroalkane, or hydroximoyl chloride). The method of generation is also critical; common methods include the dehydrohalogenation of hydroximoyl chlorides, the dehydration of primary nitroalkanes, and the oxidation of aldoximes.^{[1][8][9]} Each method has its own set of optimal conditions and potential incompatibilities with certain substrates.
- **Dipolarophile Purity:** Ensure your alkene or alkyne is pure and free of any contaminants that could interfere with the reaction.
- **Reaction Temperature:** The rate of cycloaddition is temperature-dependent. If the reaction is sluggish at room temperature, gentle heating may be necessary. However, be aware that excessive heat can lead to the decomposition of the nitrile oxide or the desired product.^[7] A systematic screen of the reaction temperature is often a good starting point.
- **Solvent Choice:** The polarity of the solvent can influence the rate of cycloaddition. While some reactions proceed well in a range of solvents, others are highly sensitive.^{[10][11]} Dioxane, for example, has been shown to significantly improve yields in certain cases.^[12]

Q2: I am observing significant amounts of a side product that I suspect is a nitrile oxide dimer. How can I prevent this?

A2: Nitrile oxide dimerization to form furoxans (1,2,5-oxadiazole-2-oxides) is a common competing reaction, especially with less reactive dipolarophiles or at high nitrile oxide concentrations.^{[13][14][15]} To mitigate this:

- **Slow Addition/Generation:** If you are generating the nitrile oxide in situ, try adding the precursor (e.g., the oxidant or base) slowly to the reaction mixture containing the

dipolarophile. This keeps the instantaneous concentration of the nitrile oxide low, favoring the intermolecular cycloaddition over dimerization.

- **Excess Dipolarophile:** Using a molar excess of the dipolarophile can also help to trap the nitrile oxide as it is formed, outcompeting the dimerization pathway.
- **Diffusion-Controlled Mixing:** For particularly challenging cases with low-reactivity dipolarophiles, a diffusion reagent mixing technique can be effective. This method helps to suppress the dimerization of rapidly forming dipoles.[16]

Q3: My reaction is producing a mixture of regioisomers. How can I improve the regioselectivity?

A3: The regioselectivity of nitrile oxide cycloadditions is primarily governed by Frontier Molecular Orbital (FMO) theory. The interaction between the Highest Occupied Molecular Orbital (HOMO) of one component and the Lowest Unoccupied Molecular Orbital (LUMO) of the other determines the preferred orientation of addition.

- **Electronic Effects:** The electronic nature of the substituents on both the nitrile oxide and the dipolarophile plays a crucial role. Modifying these substituents can alter the HOMO-LUMO energy gap and the orbital coefficients, thereby influencing the regioselectivity.
- **Lewis Acid Catalysis:** The use of a chiral Lewis acid catalyst can significantly enhance both regioselectivity and enantioselectivity.[17] The catalyst can coordinate to the dipolarophile, altering its electronic properties and creating a more ordered transition state.
- **Solvent Effects:** While generally less pronounced than electronic or catalytic effects, the solvent polarity can sometimes influence the regiochemical outcome.[11]

Troubleshooting Guide: Deeper Dive into Specific Issues

Issue 1: Inconsistent or Non-Reproducible Results

Potential Cause: Variability in the quality of reagents or subtle changes in reaction setup.

Troubleshooting Steps:

- Reagent Qualification:
 - Aldoxime Purity: If using an aldoxime precursor, ensure it is free of the corresponding aldehyde. Aldehydes can react with hydroxylamine (if present) or undergo side reactions under oxidative conditions.
 - Oxidant/Base Quality: The activity of oxidants like Oxone or bases like triethylamine can degrade over time. Use freshly opened or properly stored reagents. For instance, a green protocol using a NaCl/Oxone system for the oxidation of aldoximes has been reported to be efficient.[\[18\]](#)[\[19\]](#)[\[20\]](#)
- Strict Control of Reaction Parameters:
 - Temperature: Use a temperature-controlled reaction vessel (e.g., an oil bath or a cryostat) to maintain a consistent temperature.
 - Atmosphere: While many nitrile oxide cycloadditions are tolerant of air, sensitive substrates may benefit from being run under an inert atmosphere (e.g., nitrogen or argon).
 - Stirring: Ensure consistent and efficient stirring to maintain a homogeneous reaction mixture.

Issue 2: Formation of Complex Product Mixtures or Decomposition

Potential Cause: Incompatibility of functional groups with the reaction conditions or the inherent instability of the nitrile oxide.

Troubleshooting Steps:

- Milder Generation Methods:
 - Traditional methods for generating nitrile oxides, such as using strong bases or oxidants, can be harsh. Consider alternative, milder methods. For example, the use of tert-butyl hypoiodite (t-BuOI) offers a versatile and mild approach for generating nitrile oxides from oximes.[\[1\]](#)[\[12\]](#) Dehydration of O-silylated hydroxamic acids is another mild method.[\[8\]](#)

- Protecting Group Strategy:
 - If your dipolarophile or the precursor to your nitrile oxide contains sensitive functional groups, consider using protecting groups that are stable to the reaction conditions.
- Lower Reaction Temperature:
 - Running the reaction at a lower temperature, even if it requires a longer reaction time, can often minimize side reactions and decomposition.

Issue 3: Poor Diastereoselectivity in Reactions with Chiral Substrates

Potential Cause: Insufficient facial discrimination in the transition state.

Troubleshooting Steps:

- Chiral Auxiliaries:
 - The use of a chiral auxiliary on the dipolarophile can effectively control the facial selectivity of the cycloaddition.
- Allylic Strain and Directing Groups:
 - An allylic oxygen substituent on the alkene can have a directing effect on the incoming nitrile oxide, leading to improved diastereoselectivity.^[6]
- Chiral Catalysis:
 - As mentioned previously, chiral Lewis acids are powerful tools for inducing high levels of enantioselectivity and can also improve diastereoselectivity.^{[17][21]}

Experimental Protocols & Data

Table 1: Common Solvents and Their Impact on Yield

Solvent	Polarity (Dielectric Constant)	Typical Impact on Yield	Reference
Dioxane	2.2	Often provides good to excellent yields.	[12]
Acetonitrile	37.5	Can be effective, but may require optimization.	[1]
Dichloromethane (DCM)	9.1	Commonly used, generally gives moderate to good yields.	
Tetrahydrofuran (THF)	7.6	A versatile solvent, often used in catalyzed reactions.	[22]
Water	80.1	Can accelerate reactions with electron-rich dipolarophiles.	[11][23]

Protocol 1: In Situ Generation of Benzonitrile Oxide from Benzaldoxime using t-BuOI[12]

- To a stirred solution of benzaldoxime (0.25 mmol) and styrene (0.25 mmol) in dioxane (5 mL), add 2,6-lutidine (0.25 mmol).
- In a separate flask, prepare tert-butyl hypoiodite (t-BuOI) in situ by mixing tert-butyl hypochlorite (t-BuOCl, 0.25 mmol) and sodium iodide (NaI, 0.25 mmol) in dioxane.
- Add the freshly prepared t-BuOI solution to the benzaldoxime/styrene mixture.
- Stir the reaction at room temperature for 24 hours.
- Monitor the reaction progress by Thin Layer Chromatography (TLC).

- Upon completion, quench the reaction with a saturated aqueous solution of sodium thiosulfate.
- Extract the product with an appropriate organic solvent (e.g., ethyl acetate), dry the organic layer over anhydrous sodium sulfate, and concentrate in vacuo.
- Purify the crude product by column chromatography on silica gel.

Visualizing the Fundamentals

General Mechanism of Nitrile Oxide Cycloaddition

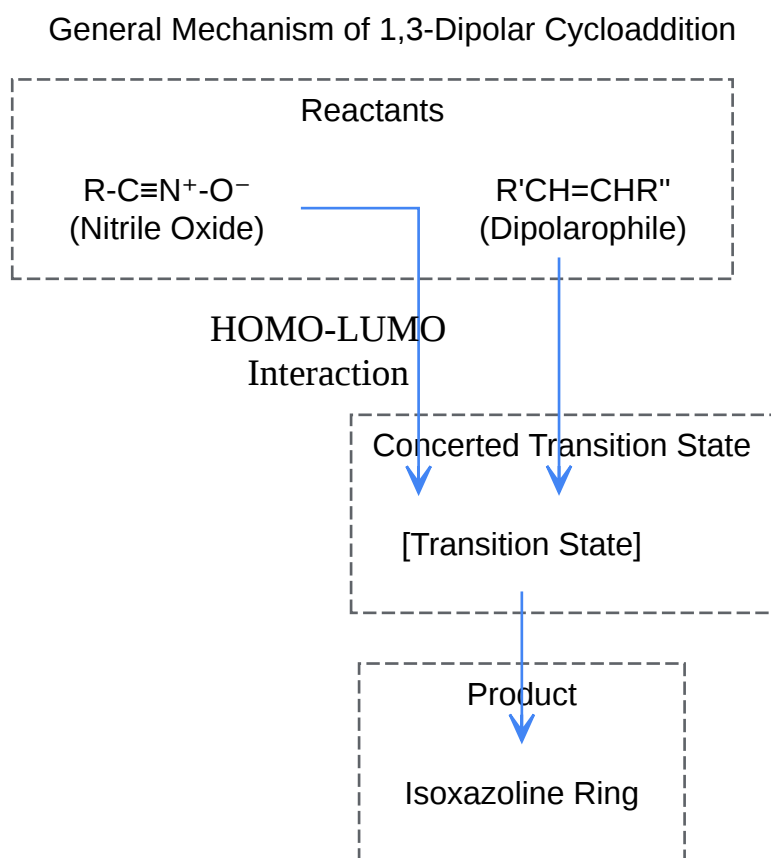

[Click to download full resolution via product page](#)

Caption: A simplified diagram showing the concerted mechanism of a 1,3-dipolar cycloaddition between a nitrile oxide and an alkene to form an isoxazoline.

Troubleshooting Workflow for Low Yield

Troubleshooting Workflow for Low Yield in Nitrile Oxide Cycloadditions

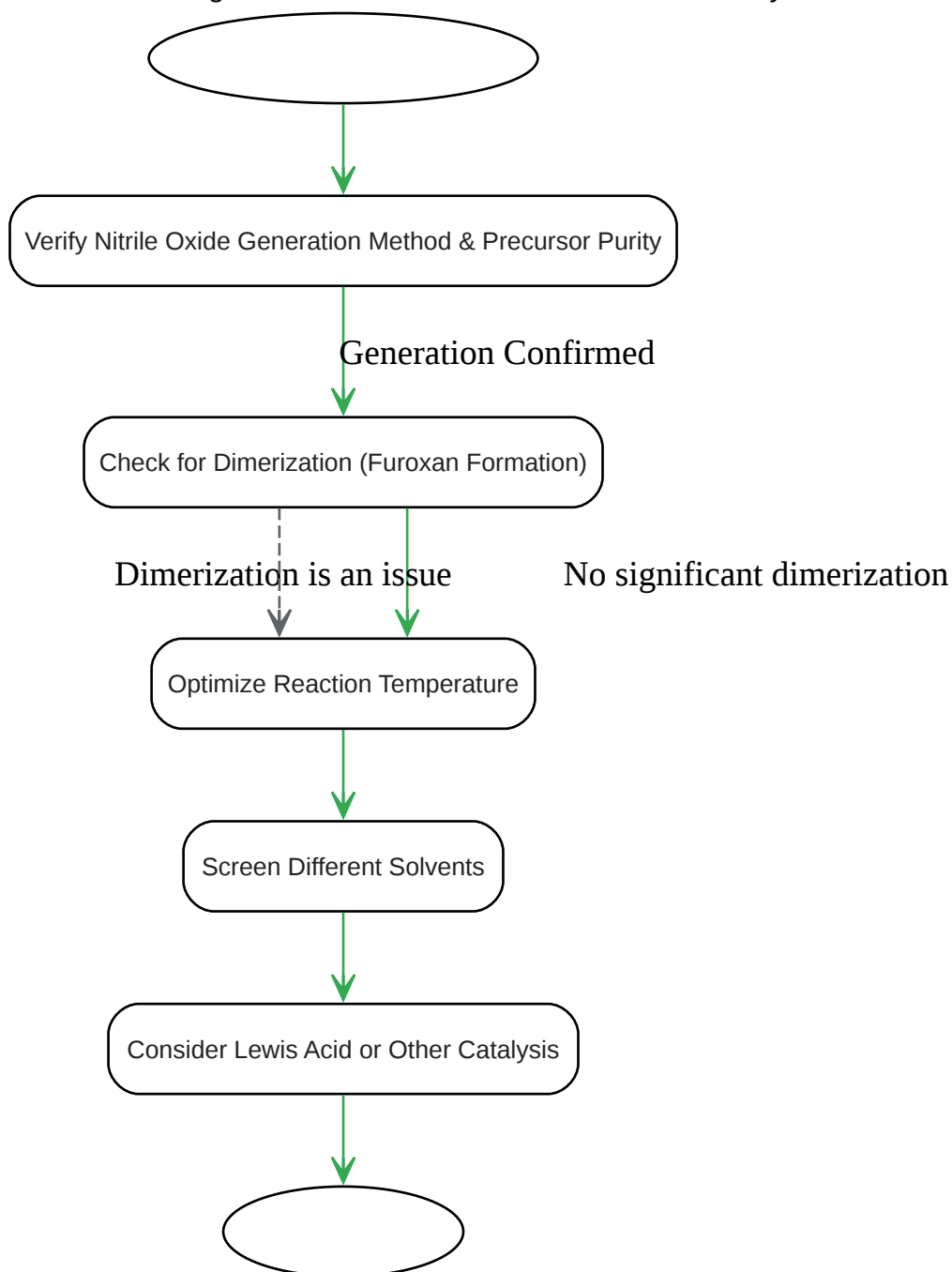

[Click to download full resolution via product page](#)

Caption: A decision-making flowchart for systematically troubleshooting low-yielding nitrile oxide cycloaddition reactions.

References

- Lee, Y. R., & Kim, Y. M. (2019). In Situ Generation of Nitrile Oxides from NaCl–Oxone Oxidation of Various Aldoximes and Their 1,3-Dipolar Cycloaddition. *Organic Letters*, 21(1), 315–319. [[Link](#)]
- Minakata, S., Okumura, S., Nagamachi, T., & Takeda, Y. (2011). Generation of Nitrile Oxides from Oximes Using t-BuOI and Their Cycloaddition. *Organic Letters*, 13(11), 2966–2969. [[Link](#)]
- Sibi, M. P., & Liu, M. (2004). Chiral Lewis Acid Catalysis in Nitrile Oxide Cycloadditions. *Organic Letters*, 6(13), 2233–2236. [[Link](#)]
- Gholami, M. R., & Zare, K. (2008). Mini-Review: Organic catalysts in the 1,3-Dipolar cycloaddition reactions of nitrile oxides. *Arkivoc*, 2008(15), 136-151. [[Link](#)]
- Shintani, R., & Fu, G. C. (2003). Catalytic Enantioselective [3 + 2] Cycloaddition of α -Keto Ester Enolates and Nitrile Oxides. *Journal of the American Chemical Society*, 125(35), 10778–10779. [[Link](#)]
- Minakata, S., Okumura, S., Nagamachi, T., & Takeda, Y. (2011). Generation of Nitrile Oxides from Oximes Using t-BuOI and Their Cycloaddition. *Organic Letters*, 13(11), 2966-2969. [[Link](#)]
- Hsueh, Y. L., Chen, C. W., & Li, W. S. (1999). An improved, easy and efficient method for the generation of nitrile oxides from nitronates for in situ 1,3-dipolar cycloaddition. *Journal of the Chemical Society, Perkin Transactions 1*, (21), 3127-3130. [[Link](#)]
- Lee, Y. R., & Kim, Y. M. (2019). In Situ Generation of Nitrile Oxides from NaCl-Oxone Oxidation of Various Aldoximes and Their 1,3-Dipolar Cycloaddition. *Organic letters*, 21(1), 315–319. [[Link](#)]
- Jasiński, R. (2023). Nitrile Oxide, Alkenes, Dipolar Cycloaddition, Isomerization and Metathesis Involved in the Syntheses of 2-Isoxazolines. *Molecules*, 28(6), 2533. [[Link](#)]
- K.B.G. Torssell. (1988).
- Mondal, S., & Ghorai, P. (2022). MnVI-NP–Catalyzed Generation of Nitrile Oxides: Easy Access to Isoxazolines and Isoxazoles via Stereoselective 1,3-Dipolar Cycloaddition. *Synlett*,

33(18), 1833-1838. [\[Link\]](#)

- Plumet, J. (2021). The 1,3-Dipolar Cycloaddition Reactions of Nitrile Oxides in Water Media. *Current Organic Chemistry*, 25(22), 2683-2707. [\[Link\]](#)
- Kündig, E. P., & Krumper, J. R. (2008). Asymmetric Lewis acid-catalyzed 1,3-dipolar cycloadditions. *Pure and Applied Chemistry*, 80(5), 1051-1060. [\[Link\]](#)
- de Oliveira, K. T., dos Santos, H. F., & de Almeida, W. B. (2018). The 1,3-Dipolar Cycloaddition of Nitrile Oxide to Vinylacetic Acid: Computational Study of Transition States Selectivity, Solvent Effects, and Bicyclo Formation. *Journal of the Brazilian Chemical Society*, 29(9), 1954-1966. [\[Link\]](#)
- de Oliveira, K. T., dos Santos, H. F., & de Almeida, W. B. (2018). The 1,3-Dipolar Cycloaddition of Nitrile Oxide to Vinylacetic Acid: Computational Study of Transition States Selectivity, Solvent Effects, and Bicyclo Formation. *Journal of the Brazilian Chemical Society*, 29(9), 1954–1966. [\[Link\]](#)
- Torsell, K. B. G. (2011). Recent advances in intramolecular nitrile oxide cycloadditions in the synthesis of 2-Isoxazolines. *Arkivoc*, 2011(1), 223-241. [\[Link\]](#)
- Wang, G. W., & Li, Y. J. (2022). [3 + 2] Cycloaddition reactions of nitrile oxides generated in situ from aldoximes with alkenes and alkynes under ball-milling conditions. *Green Chemistry Letters and Reviews*, 15(3), 520-530. [\[Link\]](#)
- Bakulev, V. A., et al. (2021). 1,3-Dipolar Cycloaddition of Nitrile Oxides and Nitrilimines to (–)-β-Caryophyllene: Stereoselective Synthesis of Polycyclic Derivatives and Their Biological Testing. *Molecules*, 26(15), 4642. [\[Link\]](#)
- Domingo, L. R., & Aurell, M. J. (2003). Dimerizations of Nitrile Oxides to Furoxans Are Stepwise via Dinitrosoalkene Diradicals: A Density Functional Theory Study. *Journal of the American Chemical Society*, 125(50), 15420-15425. [\[Link\]](#)
- Clark, J. S., et al. (2002). Preparation and reactivity of some stable nitrile oxides and nitrones. *Arkivoc*, 2002(5), 684-696. [\[Link\]](#)

- Beltrame, P., et al. (1973). Behaviour of nitrile oxides towards nucleophiles. Part III. Dimerisation of aromatic nitrile oxides catalysed by trimethylamine. *Journal of the Chemical Society, Perkin Transactions 2*, (6), 706-710. [[Link](#)]
- Benchouk, W., Mekelleche, S. M., Silvi, B., Aurell, M. J., & Domingo, L. R. (2007). Understanding the kinetic solvent effects on the 1,3-dipolar cycloaddition of benzonitrile N-oxide: a DFT study. *Journal of Physical Organic Chemistry*, 20(12), 1034-1042. [[Link](#)]
- Cardona, F., et al. (2020). Solvent-Free 1,3-Dipolar Cycloadditions of Nitrones for a More Sustainable Synthesis of Glycomimetics. *Molecules*, 25(11), 2697. [[Link](#)]
- Kanemasa, S., & Tsuge, O. (1990). Recent advances in synthetic applications of nitrile oxide cycloaddition (1981-1989). *Heterocycles*, 30(1), 719-736. [[Link](#)]
- Myers, A. G., & Movassaghi, M. (2000). A Novel, General Method for the Synthesis of Nitrile Oxides: Dehydration of O-Silylated Hydroxamic Acids. *Organic Letters*, 2(4), 457-460. [[Link](#)]
- Kozikowski, A. P., & Ghosh, A. K. (1982). Diastereofacial Selection in Nitrile Oxide Cycloaddition Reactions. The Anti-Directing Effect of an Allylic Oxygen and Some New Results on the Ring Metalation of Isoxazolines. A Synthesis of (±)-Blastmycinone. *Journal of the American Chemical Society*, 104(21), 5788-5795. [[Link](#)]
- Bakulev, V. A., et al. (2023). 1,3-Dipolar cycloaddition of nitrile imines and nitrile oxides to exocyclic C=N bonds – an approach to spiro-N-heterocycles. *Preprints.org*. [[Link](#)]
- Baranski, A. S. (2010). Optimization of reaction conditions for cycloaddition of nitrile oxide 2 with 7a. *ResearchGate*. [[Link](#)]
- Martin, G. E., et al. (2017). Isoxazoles via Cycloaddition of Terminal Alkynes and Nitrile Oxides (from Oximes). *Molbank*, 2017(4), M965. [[Link](#)]
- Deadman, J. J., & Collins, S. G. (2011). Nitrile Oxide 1,3-Dipolar Cycloaddition by Dehydration of Nitromethane Derivatives Under Continuous Flow Conditions. *Australian Journal of Chemistry*, 64(10), 1397-1401. [[Link](#)]
- Wang, G. W., & Li, Y. J. (2022). [3 + 2] Cycloaddition reactions of nitrile oxides generated in situ from aldoximes with alkenes and alkynes under ball-milling conditions. *Green Chemistry*

Letters and Reviews, 15(3), 520–530. [\[Link\]](#)

- Plumet, J. (2021). 1,3-Dipolar Cycloaddition Reactions of Nitrile Oxides under “Non-Conventional” Conditions: Green Solvents, Irradiation, and Continuous Flow. *European Journal of Organic Chemistry*, 2021(28), 3959-3975. [\[Link\]](#)
- Chem-Station. (2014). 1,3-Dipolar Cycloaddition of Nitrile Oxide. *Chem-Station Int. Ed.* [\[Link\]](#)
- Bakulev, V. A., et al. (2023). 1,3-Dipolar Cycloaddition of Nitrile Imines and Nitrile Oxides to Exocyclic C=N Bonds—An Approach to Spiro-N-Heterocycles. *Molecules*, 28(18), 6511. [\[Link\]](#)

Need Custom Synthesis?

BenchChem offers custom synthesis for rare earth carbides and specific isotopic labeling.

Email: info@benchchem.com or [Request Quote Online](#).

Sources

- 1. pubs.acs.org [pubs.acs.org]
- 2. experts.nau.edu [experts.nau.edu]
- 3. 1,3-Dipolar Cycloaddition of Nitrile Oxide | Chem-Station Int. Ed. [en.chem-station.com]
- 4. tandfonline.com [tandfonline.com]
- 5. tandfonline.com [tandfonline.com]
- 6. Diastereofacial Selection in Nitrile Oxide Cycloaddition Reactions. The Anti-Directing Effect of an Allylic Oxygen and Some New Results on the Ring Metalation of Isoxazolines. A Synthesis of (±)-Blastmycinone - PMC [pmc.ncbi.nlm.nih.gov]
- 7. pdf.benchchem.com [pdf.benchchem.com]
- 8. pubs.acs.org [pubs.acs.org]
- 9. connectsci.au [connectsci.au]
- 10. cris.biu.ac.il [cris.biu.ac.il]
- 11. scielo.br [scielo.br]

- [12. Generation of Nitrile Oxides from Oximes Using t-BuOI and Their Cycloaddition \[organic-chemistry.org\]](#)
- [13. docta.ucm.es \[docta.ucm.es\]](#)
- [14. rushim.ru \[rushim.ru\]](#)
- [15. researchgate.net \[researchgate.net\]](#)
- [16. 1,3-Dipolar Cycloaddition of Nitrile Oxides and Nitrilimines to \(-\)- \$\beta\$ -Caryophyllene: Stereoselective Synthesis of Polycyclic Derivatives and Their Biological Testing - PMC \[pmc.ncbi.nlm.nih.gov\]](#)
- [17. pubs.acs.org \[pubs.acs.org\]](#)
- [18. pubs.acs.org \[pubs.acs.org\]](#)
- [19. In Situ Generation of Nitrile Oxides from NaCl-Oxone Oxidation of Various Aldoximes and Their 1,3-Dipolar Cycloaddition - PubMed \[pubmed.ncbi.nlm.nih.gov\]](#)
- [20. Nitrile Oxide, Alkenes, Dipolar Cycloaddition, Isomerization and Metathesis Involved in the Syntheses of 2-Isloxazolines \[mdpi.com\]](#)
- [21. doc.rero.ch \[doc.rero.ch\]](#)
- [22. researchgate.net \[researchgate.net\]](#)
- [23. benthamdirect.com \[benthamdirect.com\]](#)
- To cite this document: BenchChem. [Technical Support Center: Optimization of Reaction Conditions for Nitrile Oxide Cycloadditions]. BenchChem, [2026]. [Online PDF]. Available at: [<https://www.benchchem.com/product/b2610386#optimization-of-reaction-conditions-for-nitrile-oxide-cycloadditions>]

Disclaimer & Data Validity:

The information provided in this document is for Research Use Only (RUO) and is strictly not intended for diagnostic or therapeutic procedures. While BenchChem strives to provide accurate protocols, we make no warranties, express or implied, regarding the fitness of this product for every specific experimental setup.

Technical Support: The protocols provided are for reference purposes. Unsure if this reagent suits your experiment? [[Contact our Ph.D. Support Team for a compatibility check](#)]

Need Industrial/Bulk Grade? [Request Custom Synthesis Quote](#)

BenchChem

Our mission is to be the trusted global source of essential and advanced chemicals, empowering scientists and researchers to drive progress in science and industry.

Contact

Address: 3281 E Guasti Rd

Ontario, CA 91761, United States

Phone: (601) 213-4426

Email: info@benchchem.com