

Minimizing side reactions during furan ring functionalization

Author: BenchChem Technical Support Team. **Date:** May 2026

Compound of Interest

Compound Name: *N-butyl-2-methyl-5-phenylfuran-3-carboxamide*

CAS No.: 941005-74-9

Cat. No.: B2609499

[Get Quote](#)

Furan Functionalization Technical Support Center

Ticket Status: OPEN Subject: Minimizing Side Reactions in Furan Ring Functionalization

Assigned Specialist: Senior Application Scientist

Introduction: The Furan Paradox

Welcome to the Furan Functionalization Help Desk. If you are here, you have likely encountered the "Furan Paradox": the very electron density that makes furan an excellent nucleophile also renders it hypersensitive to acid-catalyzed decomposition (resinification) and oxidation.

Unlike benzene, furan is not a true aromatic fortress. Its resonance energy is significantly lower (16 kcal/mol vs. 36 kcal/mol for benzene), making the diene character pronounced. This guide moves beyond standard textbook answers to address the three primary failure modes: Acid-

Induced Polymerization, Ring Fragmentation during Metalation, and Regiochemical Scrambling.

Troubleshooting Module: The "Black Tar" Incident (Acylation & Alkylation)

User Issue: "I attempted a Friedel-Crafts acylation using

, but the reaction mixture turned into a black, insoluble tar within minutes."

Root Cause Analysis: Standard Lewis acids like Aluminum Chloride (

) are too harsh for furan. They coordinate strongly to the oxygen atom or protonate the C2 position, initiating a cascade of electrophilic attacks by other furan molecules. This leads to rapid polymerization (resinification) or hydrolytic ring opening to 1,4-dicarbonyls [1].

Corrective Protocol: The Modified Vilsmeier-Haack Approach

For formylation or acylation, avoid standard Friedel-Crafts conditions. The Vilsmeier-Haack reaction provides a "buffered" electrophile (the iminium salt) that is reactive enough to functionalize but stable enough to prevent polymerization.

Step-by-Step Protocol:

- Reagent Prep: In a flame-dried flask under , cool anhydrous DMF (1.2 equiv) to 0°C.
- Electrophile Generation: Add (1.1 equiv) dropwise. Critical: Maintain temp < 5°C. Stir for 30 min to form the Vilsmeier salt (white precipitate/slurry).
- Substrate Addition: Dilute furan (1.0 equiv) in anhydrous DCM or 1,2-DCE. Add slowly to the salt at 0°C.
- Reaction: Warm to RT. If the furan is electron-deficient, mild heating (40°C) may be required.
- Quench (The Danger Zone): Pour mixture onto crushed ice/NaOAc buffer. Do not use strong base (NaOH) immediately, as the Cannizzaro reaction can degrade the resulting furfural.

Alternative: Mild Friedel-Crafts (If Vilsmeier is unsuitable) If you must use Friedel-Crafts (e.g., for alkylation), switch to "Soft" Lewis Acids and Anhydrides.

Parameter	Standard (AVOID)	Optimized (RECOMMENDED)	Reason
Catalyst	,	,	Softer Lewis acids minimize coordination to furan oxygen [2].
Electrophile	Acid Chlorides (RCOCl)	Acid Anhydrides	Anhydrides generate carboxylate byproducts that buffer the solution.
Solvent	Nitrobenzene	, Nitromethane	Non-nucleophilic, polar solvents stabilize the intermediate complex.

Visualizing the Failure Mode

The diagram below illustrates the mechanistic pathway of acid-catalyzed failure vs. successful functionalization.

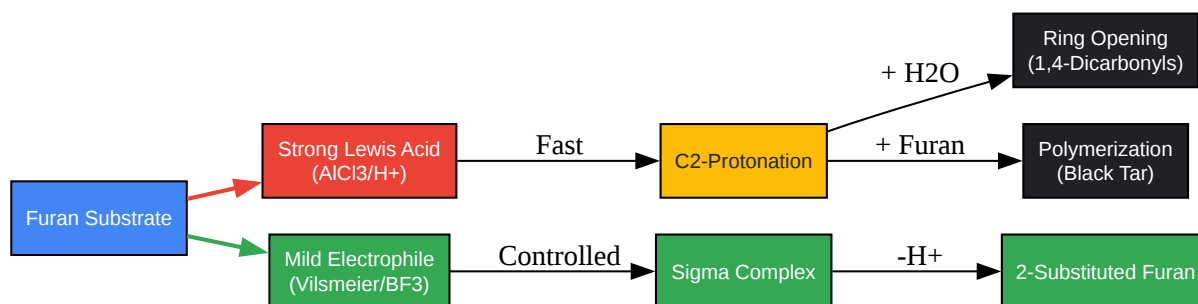

[Click to download full resolution via product page](#)

Figure 1: Mechanism of acid-catalyzed failure modes (Red path) versus controlled functionalization (Green path).

Troubleshooting Module: The "Vanishing Nucleophile" (Lithiation)

User Issue: "I generated 2-lithiofuran at 0°C. Upon adding the electrophile, I recovered a complex mixture of ring-opened enynes and starting material."

Root Cause Analysis: 2-Lithiofuran is thermally unstable. Above -20°C, it undergoes a retro-electrocyclic ring opening to form linear lithium enyne species. This is irreversible. Furthermore, direct lithiation with n-BuLi often leads to competitive C3 lithiation or dilithiation if temperature is not strictly controlled [3].

Corrective Protocol: Cryogenic Transmetallation

To stabilize the furan anion, you must work at cryogenic temperatures and consider transmetallating to a less electropositive metal (Zinc or Magnesium).

Step-by-Step Protocol:

- Cryogenic Setup: Cool THF to -78°C (Dry ice/Acetone). Do not attempt at 0°C.
- Deprotonation: Add n-BuLi (1.1 equiv) dropwise to furan. Stir at -78°C for 30-60 mins.
- Transmetallation (The Stabilizer):
 - Add

(solution in THF) or

at -78°C.
 - Warm to 0°C. The resulting Furyl-Zinc or Furyl-Magnesium species is significantly more stable than the Lithium species and tolerates higher reaction temperatures without ring opening.
- Electrophile Addition: Add your electrophile (aldehyde, ketone, halide) to the metallated furan.

- Negishi Coupling: If using Furyl-Zinc, this is now a perfect substrate for Pd-catalyzed Negishi coupling, avoiding the harsh conditions of direct arylation.

Stability Data Table:

Species	Critical Temp Limit	Primary Decomposition Mode
2-Lithiofuran	> -20°C	Ring fragmentation to enynes
3-Lithiofuran	> -40°C	Rapid isomerization to 2-lithiofuran (via "Lithium Walk")
2-Furylzinc Chloride	Stable at RT	Minimal decomposition; safe for Negishi coupling

Troubleshooting Module: Regiochemical Scrambling (C-H Activation)

User Issue: "I need to functionalize the C3 position, but electrophilic substitution exclusively gives C2 products."

Root Cause Analysis: The C2 position (alpha) is kinetically favored due to better stabilization of the intermediate cation by the oxygen lone pair. Accessing C3 requires blocking C2 or using Directing Group (DG) assisted C-H activation.

Corrective Protocol: Pd-Catalyzed C-H Activation

Modern Pd-catalyzed methods allow for regioselective functionalization without pre-functionalization (like halogenation).

Strategy 1: C2-Blocking Use a silyl group (

) at C2. It directs substitution to C3 (or C5) and can be removed later with fluoride sources (TBAF).

Strategy 2: Direct C3-Arylation (The "Fagnou" Conditions) Using specific bulky ligands and pivalic acid as a proton shuttle can favor C3 functionalization in specific substrates, though C2

remains the default for unsubstituted furan.

Recommended Workflow for C2-Alkylation (Green Chemistry): Instead of Friedel-Crafts, use Pd-catalyzed direct alkylation [4].

- Catalyst:

(5 mol%)
- Ligand:

or Xantphos
- Base:
- Reagent: Alkyl Iodide[1]
- Conditions: 110°C in Toluene.
- Why: This avoids Lewis acids entirely, preventing polymerization.

Decision Matrix: Selecting the Right Method

Use this decision tree to select the safest functionalization route based on your substrate's sensitivity.

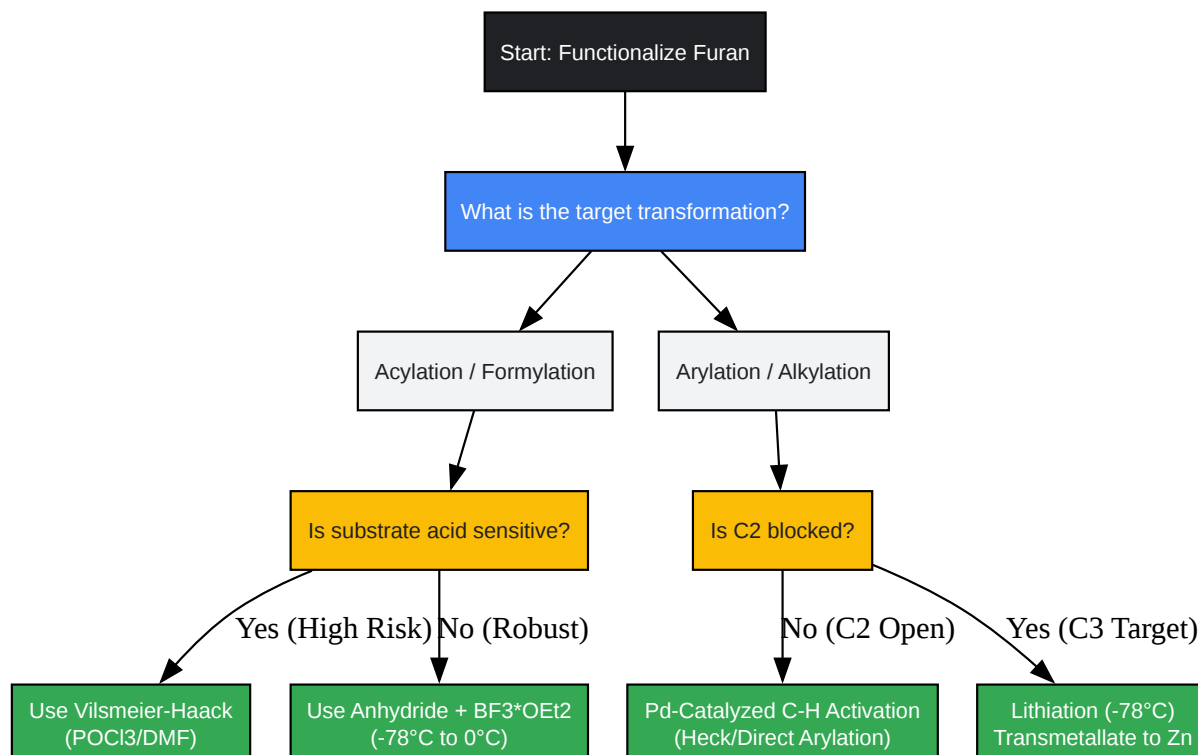

[Click to download full resolution via product page](#)

Figure 2: Decision matrix for selecting functionalization protocols to minimize side reactions.

Frequently Asked Questions (FAQ)

Q: My furan substrate has an acetal protecting group. Can I use

? A: Proceed with extreme caution.

generates HCl in situ. You must use an excess of base (like 2,6-lutidine) or switch to the Duff Reaction (HMTA/TFA) if the acetal is acid-labile, though Vilsmeier is generally preferred if buffered correctly.

Q: Why does my furan turn yellow/brown simply upon standing in air? A: Furan is susceptible to photo-oxidation and autoxidation to form peroxides and eventually maleic anhydride derivatives. Troubleshooting: Always store furan derivatives under Nitrogen/Argon, in the dark, and preferably over activated molecular sieves or Cu stabilizers.

Q: Can I use n-BuLi at 0°C for just 5 minutes? A: It is not recommended. While kinetic deprotonation is fast, the rate of ring fragmentation accelerates exponentially with temperature. If -78°C is unavailable, use LDA (Lithium Diisopropylamide) which is less nucleophilic and provides slightly better control, but cryogenic conditions remain the gold standard.

References

- Marullo, S. et al. (2017). "Acid-Catalyzed Ring Opening of Furan in Aqueous Solution." *Energy & Fuels*. [Link](#)
- Opietnik, M. et al. (2012). "Mild Friedel-Crafts Acylation of Furan with Carboxylic Acids and the Heterogeneous Catalyst Couple AIPW12O40 / Mg(OH)2." *Current Organic Chemistry*. [Link](#)
- Gschwend, H. W., & Rodriguez, H. R. (1979). "Heteroatom-Facilitated Lithiations." *Organic Reactions*.^{[1][2][3][4][5][6][7]} (Foundational text on lithiofuran instability).
- Liu, C. et al. (2021).^[1] "Regioselective Pd-catalyzed α -alkylation of furans using alkyl iodides." *RSC Advances*. [Link](#)
- BenchChem Technical Support. (2025). "Vilsmeier-Haack Formylation Protocols."^[8] [Link](#)

Need Custom Synthesis?

BenchChem offers custom synthesis for rare earth carbides and specific isotopic labeling.

Email: info@benchchem.com or [Request Quote Online](#).

Sources

- [1. Regioselective Pd-catalyzed \$\alpha\$ -alkylation of furans using alkyl iodides - RSC Advances \(RSC Publishing\) DOI:10.1039/D1RA01522B \[pubs.rsc.org\]](#)
- [2. Furan synthesis \[organic-chemistry.org\]](#)
- [3. pdf.benchchem.com \[pdf.benchchem.com\]](#)
- [4. pdf.benchchem.com \[pdf.benchchem.com\]](#)

- [5. Regioselective C-Arylation of Functionalized Nitroalkanes with Furan, Thiophene, and Substituted Thiophenes - PMC \[pmc.ncbi.nlm.nih.gov\]](#)
- [6. discovery.ucl.ac.uk \[discovery.ucl.ac.uk\]](#)
- [7. eurekaselect.com \[eurekaselect.com\]](#)
- [8. pdf.benchchem.com \[pdf.benchchem.com\]](#)
- To cite this document: BenchChem. [Minimizing side reactions during furan ring functionalization]. BenchChem, [2026]. [Online PDF]. Available at: [\[https://www.benchchem.com/product/b2609499/docs#minimizing-side-reactions-during-furan-ring-functionalization\]](https://www.benchchem.com/product/b2609499/docs#minimizing-side-reactions-during-furan-ring-functionalization)

Disclaimer & Data Validity:

The information provided in this document is for Research Use Only (RUO) and is strictly not intended for diagnostic or therapeutic procedures. While BenchChem strives to provide accurate protocols, we make no warranties, express or implied, regarding the fitness of this product for every specific experimental setup.

Technical Support: The protocols provided are for reference purposes. Unsure if this reagent suits your experiment?

Need Industrial/Bulk Grade? [Request Custom Synthesis Quote](#)

BenchChem

Our mission is to be the trusted global source of essential and advanced chemicals, empowering scientists and researchers to drive progress in science and industry.

Contact

Address: 3281 E Guasti Rd

Ontario, CA 91761, United States

Phone: (601) 213-4426

Email: info@benchchem.com

Contact our Ph.D. Support Team for a compatibility check