

# Introduction: Illuminating the Molecular Architecture of a Privileged Scaffold

**Author:** BenchChem Technical Support Team. **Date:** April 2026

## Compound of Interest

Compound Name:	2-(2-Fluorophenyl)-1,3-thiazole-5-carbaldehyde
CAS No.:	914347-94-7
Cat. No.:	B2606344

[Get Quote](#)

The 2-phenylthiazole moiety is a "privileged structure" in medicinal chemistry, forming the core of numerous compounds with a broad spectrum of biological activities, including antifungal, anti-inflammatory, and cholinesterase inhibition properties.[1][2][3] Understanding the precise three-dimensional arrangement of atoms within these molecules is paramount for deciphering structure-activity relationships (SAR), optimizing drug-target interactions, and predicting solid-state properties. Single-crystal X-ray diffraction (XRD) stands as the definitive method for providing this atomic-resolution insight.[4]

This guide offers a comparative analysis of the X-ray crystallographic techniques applied to 2-phenylthiazole derivatives. Moving beyond a simple recitation of protocols, we will explore the causality behind experimental choices—from crystal growth to data refinement—and present a comparative analysis of published structural data. This content is designed for researchers, scientists, and drug development professionals seeking to leverage crystallographic insights in their work with this important class of compounds.

# The Crystallization Challenge: From Soluble Molecule to Diffracting Crystal

The first and often most challenging step in any crystallographic analysis is obtaining a high-quality single crystal suitable for diffraction.<sup>[5]</sup> For 2-phenylthiazole derivatives, which are typically small organic molecules, several techniques can be employed. The choice of method and solvent is critical and often requires empirical screening.

## Comparative Crystallization Strategies

Method	Principle	Advantages	Common Solvents for 2-Phenylthiazoles
Slow Solvent Evaporation	The compound is dissolved in a suitable solvent, which is then allowed to evaporate slowly, gradually increasing the concentration until saturation is exceeded and crystals form.[6]	Simple setup, requires minimal material.	Ethanol, Methanol, Acetone, Ethyl Acetate, Dichloromethane.[7] [8]
Vapor Diffusion	A concentrated solution of the compound is placed in a small vial, which is then sealed inside a larger chamber containing a "precipitant" solvent in which the compound is poorly soluble. The vapor of the precipitant slowly diffuses into the compound's solution, reducing its solubility and inducing crystallization.	Finer control over the rate of crystallization, can yield higher quality crystals.	A common setup involves dissolving the compound in a solvent like Dichloromethane and using a precipitant like Hexane or Pentane.
Cooling	A saturated solution of the compound is prepared at an elevated temperature and then slowly cooled. As the temperature	Effective for compounds with a steep solubility-temperature gradient.	Acetonitrile, Isopropanol.

decreases, the solubility of the compound drops, leading to crystallization.

---

Expert Insight: The choice of solvent is not arbitrary. It is governed by the polarity of the 2-phenylthiazole derivative. Substituents on the phenyl or thiazole rings can dramatically alter solubility. A good starting point is to use a solvent in which the compound is moderately soluble; if it is too soluble, evaporation will be too slow, and if it is poorly soluble, it will be difficult to achieve the necessary concentration.<sup>[6]</sup>

## Experimental Protocol: Crystallization by Slow Evaporation

- Preparation: Dissolve 5-10 mg of the purified 2-phenylthiazole derivative in a minimal amount (0.5-1.0 mL) of a chosen solvent (e.g., ethanol) in a small, clean glass vial.
- Dissolution: Gently warm the vial or use sonication to ensure the compound is fully dissolved.
- Filtration (Optional but Recommended): Filter the solution through a syringe filter (0.22  $\mu\text{m}$ ) into a clean vial to remove any particulate matter that could act as unwanted nucleation sites.
- Evaporation: Cover the vial with parafilm and pierce it with a needle 1-2 times. This slows the rate of evaporation, which is crucial for the growth of large, well-ordered single crystals.
- Incubation: Place the vial in a vibration-free location at a constant room temperature.
- Monitoring: Observe the vial daily for the formation of crystals. This process can take anywhere from a few days to several weeks.

## Workflow for Structural Elucidation

The journey from a synthesized compound to a refined crystal structure follows a well-defined path. Each stage requires careful execution and quality assessment to ensure the final model

is accurate and reliable.

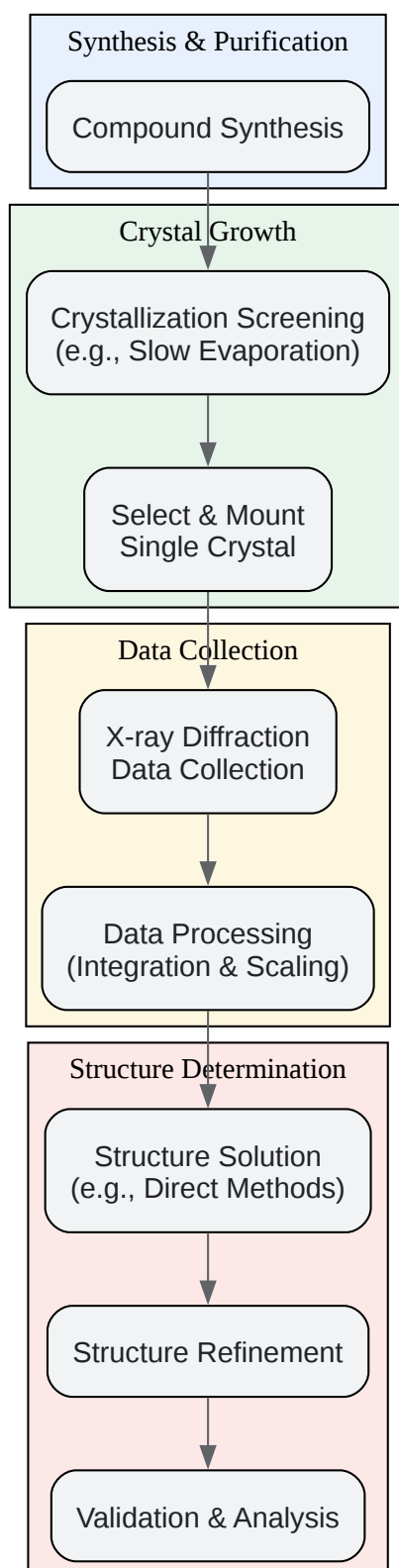

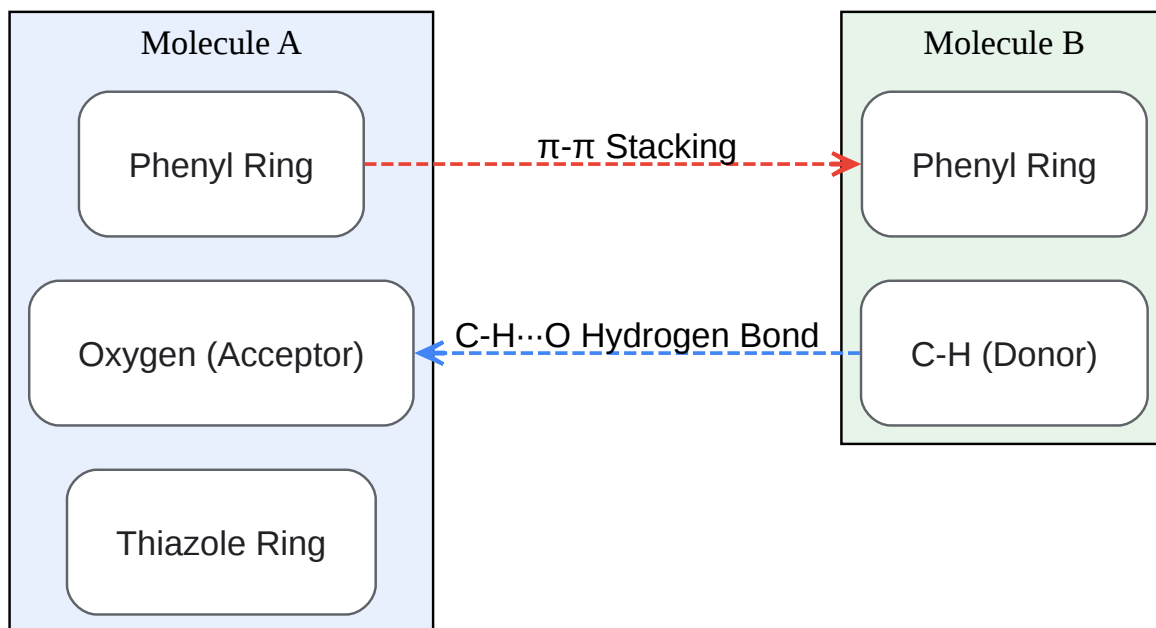

[Click to download full resolution via product page](#)

### Need Custom Synthesis?

BenchChem offers custom synthesis for rare earth carbides and specific isotopic labeling.

Email: [info@benchchem.com](mailto:info@benchchem.com) or [Request Quote Online](#).

## Sources

- 1. Design, synthesis, and biological evaluation of 2-phenylthiazole CYP51 inhibitors - PMC [[pmc.ncbi.nlm.nih.gov](https://pubmed.ncbi.nlm.nih.gov/)]
- 2. [pdf.benchchem.com](https://pdf.benchchem.com) [[pdf.benchchem.com](https://pdf.benchchem.com)]
- 3. [pdf.benchchem.com](https://pdf.benchchem.com) [[pdf.benchchem.com](https://pdf.benchchem.com)]
- 4. Small molecule X-ray crystallography - School of Chemistry and Molecular Biosciences - University of Queensland [[scmb.uq.edu.au](https://scmb.uq.edu.au)]
- 5. [creative-biostructure.com](https://creative-biostructure.com) [[creative-biostructure.com](https://creative-biostructure.com)]
- 6. Pharmaceutical Co-Crystallization: Regulatory Aspects, Design, Characterization, and Applications [[apb.tbzmed.ac.ir](https://apb.tbzmed.ac.ir)]

- [7. Synthesis and Structure Determination of Substituted Thiazole Derivatives as EGFR/BRAFV600E Dual Inhibitors Endowed with Antiproliferative Activity - PMC \[pmc.ncbi.nlm.nih.gov\]](#)
- [8. mdpi.com \[mdpi.com\]](#)
- To cite this document: BenchChem. [Introduction: Illuminating the Molecular Architecture of a Privileged Scaffold]. BenchChem, [2026]. [Online PDF]. Available at: [\[https://www.benchchem.com/product/b2606344/docs#introduction-illuminating-the-molecular-architecture-of-a-privileged-scaffold\]](https://www.benchchem.com/product/b2606344/docs#introduction-illuminating-the-molecular-architecture-of-a-privileged-scaffold)

---

### Disclaimer & Data Validity:

The information provided in this document is for Research Use Only (RUO) and is strictly not intended for diagnostic or therapeutic procedures. While BenchChem strives to provide accurate protocols, we make no warranties, express or implied, regarding the fitness of this product for every specific experimental setup.

**Technical Support:** The protocols provided are for reference purposes. Unsure if this reagent suits your experiment?

**Need Industrial/Bulk Grade?** [Request Custom Synthesis Quote](#)

## BenchChem

Our mission is to be the trusted global source of essential and advanced chemicals, empowering scientists and researchers to drive progress in science and industry.

### Contact

Address: 3281 E Guasti Rd  
Ontario, CA 91761, United States  
Phone: (601) 213-4426  
Email: [info@benchchem.com](mailto:info@benchchem.com)

[Contact our Ph.D. Support Team for a compatibility check](#)

