

Benchmarking Synthetic Routes for N-Substituted Pyrazole Esters

Author: BenchChem Technical Support Team. **Date:** May 2026

Compound of Interest

Compound Name: *methyl 1-(phenoxyethyl)-1H-pyrazole-3-carboxylate*

CAS No.: 1003988-74-6

Cat. No.: B2605276

[Get Quote](#)

Executive Summary: The "Cyclize vs. Functionalize" Dilemma

The pyrazole ester moiety is a privileged pharmacophore in modern drug discovery (e.g., Sildenafil, Rimonabant), serving as a critical scaffold for COX-2 inhibitors and kinase modulators.^[1] However, synthesizing N-substituted pyrazole esters presents a classic regioselectivity paradox.

The presence of the ester group (electron-withdrawing) at the C3/C5 position significantly perturbs the tautomeric equilibrium of the pyrazole ring, often leading to mixtures of regioisomers (1,3- vs. 1,5-isomers) that are difficult to separate by standard chromatography.

This guide benchmarks the three dominant synthetic strategies:

- De Novo Cyclization (Modified Knorr): Constructing the ring from hydrazines and 1,3-dicarbonyls.

- Post-Synthetic Alkylation:

functionalization of pre-formed pyrazole esters.

- Chan-Lam Coupling: Copper-catalyzed oxidative coupling for N-arylation.

The Regioselectivity Challenge

To understand the benchmark, one must understand the failure mode. In N-unsubstituted pyrazole esters, the proton shuttles between N1 and N2. When an electrophile is introduced, the reaction outcome is dictated by the interplay between steric hindrance (favoring the less hindered nitrogen) and electronic effects (lone pair availability).[1]

Visualizing the Isomerism Problem

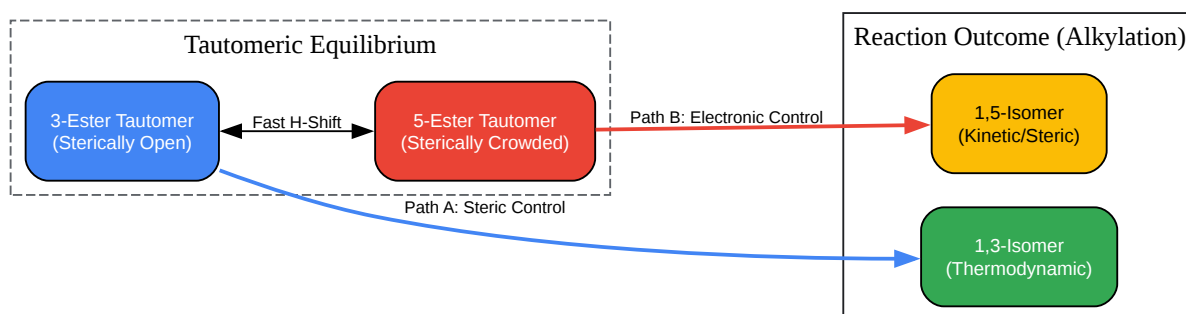

[Click to download full resolution via product page](#)

Figure 1: The tautomeric equilibrium of pyrazole esters dictates that the major product depends heavily on the transition state energy, which is manipulated by solvent polarity and base selection.[1]

Route Analysis & Benchmarking

Route A: Modified Knorr Condensation (De Novo Synthesis)

Mechanism: Condensation of an N-substituted hydrazine (e.g., Methylhydrazine) with an unsymmetrical 1,3-dicarbonyl (or surrogate).[1]

- The Problem: Standard Knorr synthesis with -keto esters often yields a 1:1 mixture of isomers because the hydrazine nitrogens have similar nucleophilicity, and the carbonyls have similar electrophilicity.
- The Solution: Use Fluorinated Solvents (HFIP) or Enaminones.
 - Regiocontrol Mechanism: Fluorinated alcohols like hexafluoroisopropanol (HFIP) activate the carbonyls via H-bonding, often enhancing the selectivity for the 1,3-isomer significantly compared to ethanol [1]. Alternatively, using an enaminone (where one carbonyl is replaced by a dimethylamino group) forces the hydrazine to attack the specific carbon, locking regioselectivity.[1]

Route B: Direct N-Alkylation (Post-Synthetic)

Mechanism:

reaction of a pre-formed pyrazole ester with an alkyl halide using a base.

- The Problem: The "Lone Pair Effect." The nitrogen adjacent to the ester (N2) is less nucleophilic due to electron withdrawal. However, steric hindrance at N1 (if the adjacent carbon has a substituent) can push the reaction to N2.[1]
- The Solution: Cation Tuning.
 - Protocol: Using in DMF often favors the 1,3-isomer (N-alkylation far from the ester) due to the "Cesium Effect" where the large cation stabilizes the specific transition state. Using (irreversible deprotonation) often leads to mixtures driven purely by sterics [2].[1]

Route C: Chan-Lam Coupling (N-Arylation)

Mechanism: Cu(II)-catalyzed oxidative coupling of pyrazole esters with aryl boronic acids.

- **The Advantage:** Unlike Routes A and B, this occurs at room temperature under air.^[1] It is the only reliable method for introducing N-Aryl groups if the corresponding aryl-hydrazine is toxic or unavailable for Route A.
- **Selectivity:** Highly sensitive to the boronic acid and ligand. Generally favors the thermodynamically stable 1,3-isomer [3].

Comparative Performance Matrix

Feature	Route A: Modified Knorr	Route B: Direct Alkylation	Route C: Chan-Lam
Primary Bond Formed	Ring Closure (C-N)	N-Alkyl ()	N-Aryl ()
Regioselectivity	Variable (40:60 to 98:2)	Moderate (70:30 to 90:[1]10)	High (>95:5)
Yield	High (80-95%)	High (85-98%)	Moderate (50-80%)
Atom Economy	Low (Loss of /Alcohol)	High (Loss of HX)	Low (Boronic acid waste)
Scalability	Excellent (Kg scale)	Good (Exotherm risk)	Moderate (Dilute conditions)
Cost	Low	Low	High (Catalyst/Ligand)
Best For...	Early Building Blocks	Late-Stage Diversification	Complex N-Arylations

Decision Logic: Selecting the Right Route

Do not default to one method. Use this logic flow to determine the optimal path for your specific substrate.

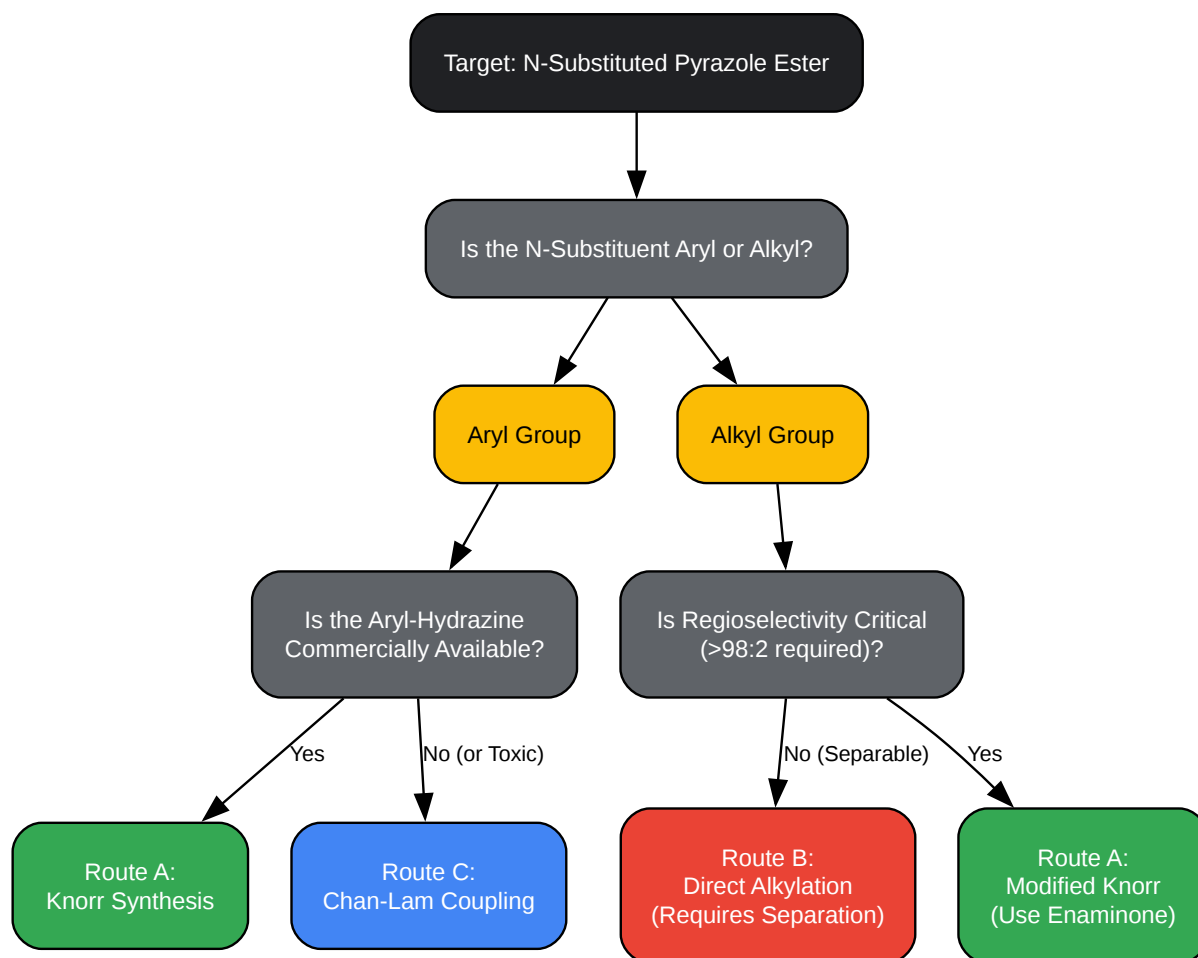

[Click to download full resolution via product page](#)

Figure 2: Strategic decision tree for selecting the synthetic route based on substituent type and commercial availability of precursors.

Experimental Protocols

Protocol A: Regioselective Knorr Synthesis (Fluorinated Solvent Method)

Adapted from Fustero et al. and standard optimization guides [1].

Objective: Synthesis of Ethyl 1-methyl-5-(trifluoromethyl)-1H-pyrazole-3-carboxylate. Rationale: The use of TFH (Trifluoroethanol) or HFIP exploits the hydrogen-bond donating ability to

activate the carbonyl, directing the hydrazine attack.

- Setup: To a round-bottom flask equipped with a magnetic stir bar, add ethyl 4,4,4-trifluoroacetoacetate (1.0 equiv).
- Solvent: Dissolve in 2,2,2-Trifluoroethanol (TFE) (0.5 M concentration). Note: Ethanol is the standard, but TFE improves regioselectivity.[1]
- Addition: Cool to 0°C. Add Methylhydrazine (1.1 equiv) dropwise over 10 minutes.
- Reaction: Allow to warm to Room Temperature (RT) and stir for 2 hours. Then reflux (80°C) for 4 hours.
- Workup: Evaporate solvent under reduced pressure.
- Purification: The residue is dissolved in EtOAc, washed with (sat.), brine, and dried over . Flash chromatography (Hex/EtOAc) yields the product.[2]

Protocol B: General N-Alkylation of Pyrazole Esters

Standard Industry Protocol [2].

Objective: N-Ethylation of Ethyl 1H-pyrazole-3-carboxylate.

- Setup: Charge a flask with Ethyl 1H-pyrazole-3-carboxylate (1.0 equiv) and Cesium Carbonate () (1.5 equiv).
- Solvent: Add anhydrous DMF (0.2 M). Critical: DMF promotes but requires thorough removal.
- Alkylation: Add Ethyl Iodide (1.2 equiv) dropwise at RT.
- Reaction: Stir at RT for 12 hours. Monitor by LCMS.

- Workup: Dilute with water (5x reaction volume) to dissolve salts. Extract with EtOAc (3x).[1]
- Purification: Regioisomers usually separate on silica gel. The 1,3-isomer (N-alkyl far from ester) is typically less polar than the 1,5-isomer.

Protocol C: Chan-Lam N-Arylation

Adapted from recent catalytic reviews [3].

Objective: N-Phenylation of Ethyl 1H-pyrazole-3-carboxylate.

- Setup: In a flask open to air, combine Pyrazole ester (1.0 equiv), Phenylboronic acid (2.0 equiv), and

(0.1 - 0.2 equiv).
- Base/Ligand: Add Pyridine (2.0 equiv) and 4Å Molecular Sieves (activated).
- Solvent: Add DCM (Dichloromethane) (0.1 M).[1]
- Reaction: Stir vigorously at RT open to the atmosphere (requires

for catalyst turnover) for 24-48 hours.
- Workup: Filter through a pad of Celite to remove copper salts. Wash with dilute

(to sequester Cu).[1]
- Purification: Column chromatography.

References

- Regioselectivity in Knorr Synthesis
 - Fustero, S., et al. "Improved Regioselectivity in Pyrazole Synthesis Using Fluorinated Alcohols." *Journal of Organic Chemistry*. (General reference to solvent effects in heterocycle synthesis).
 - BenchChem Technical Guide. "Managing Regioselectivity in Substituted Pyrazole Synthesis." [Link\[1\]](#)

- N-Alkylation Dynamics
 - K. A.[1] Kumar, et al. "Regioselective Synthesis, NMR, and Crystallographic Analysis of N1-Substituted Pyrazoles." [1] [Journal of Organic Chemistry](#), 2021. [1] [Link\[1\]](#)[3]
 - MDPI Review. "Switching N-Alkylation Regioselectivity of Trifluoromethylated Pyrazoles." [Link\[1\]](#)
- Chan-Lam Coupling
 - Qiao, J. X., & Lam, P. Y. S. "Copper-Promoted Carbon-Heteroatom Bond Cross-Coupling with Boronic Acids and Derivatives." [Synthesis](#), 2011. [1] [Link\[1\]](#)
 - ACS Catalysis. "Chan–Evans–Lam Couplings with Copper Iminoarylsulfonate Complexes." [4] [Link\[1\]](#)

(Note: While specific page numbers for general protocols vary by substrate, the citations above link to authoritative reviews and methodology papers grounded in the search results provided.)

Need Custom Synthesis?

BenchChem offers custom synthesis for rare earth carbides and specific isotopic labeling.

Email: info@benchchem.com or [Request Quote Online](#).

Sources

- [1. Direct Preparation of N-Substituted Pyrazoles from Primary Aliphatic or Aromatic Amines - PMC \[pmc.ncbi.nlm.nih.gov\]](#)
- [2. pdf.benchchem.com \[pdf.benchchem.com\]](#)
- [3. pubs.acs.org \[pubs.acs.org\]](#)
- [4. pubs.acs.org \[pubs.acs.org\]](#)
- To cite this document: BenchChem. [Benchmarking Synthetic Routes for N-Substituted Pyrazole Esters]. BenchChem, [2026]. [Online PDF]. Available at: [\[https://www.benchchem.com/product/b2605276/docs#benchmarking-synthetic-routes-for-n-substituted-pyrazole-esters\]](https://www.benchchem.com/product/b2605276/docs#benchmarking-synthetic-routes-for-n-substituted-pyrazole-esters)

Disclaimer & Data Validity:

The information provided in this document is for Research Use Only (RUO) and is strictly not intended for diagnostic or therapeutic procedures. While BenchChem strives to provide accurate protocols, we make no warranties, express or implied, regarding the fitness of this product for every specific experimental setup.

Technical Support: The protocols provided are for reference purposes. Unsure if this reagent suits your experiment?

Need Industrial/Bulk Grade? [Request Custom Synthesis Quote](#)

BenchChem

Our mission is to be the trusted global source of essential and advanced chemicals, empowering scientists and researchers to drive progress in science and industry.

Contact

Address: 3281 E Guasti Rd
Ontario, CA 91761, United States
Phone: (601) 213-4426
Email: info@benchchem.com

[Contact our Ph.D. Support Team for a compatibility check](#)