

Introduction: The Significance of a Functionalized Pyrrole Scaffold

Author: BenchChem Technical Support Team. **Date:** April 2026

Compound of Interest

Compound Name: 5-ethyl-1H-pyrrole-2-carbaldehyde

CAS No.: 52115-68-1

Cat. No.: B2604835

[Get Quote](#)

Pyrrole-2-carboxaldehyde and its derivatives are a class of heterocyclic compounds of significant interest, found in natural products and serving as versatile building blocks in organic synthesis.[1] The molecule **5-ethyl-1H-pyrrole-2-carbaldehyde** (CAS 52115-68-1) combines the aromatic pyrrole ring with two key functional groups: an electron-withdrawing aldehyde at the 2-position and an electron-donating ethyl group at the 5-position. This specific arrangement of substituents creates a unique electronic landscape that dictates its reactivity and potential for creating more complex molecular architectures.[2][3]

Understanding the electronic properties of this molecule is paramount for its effective utilization. For drug development professionals, these properties influence how the molecule interacts with biological targets. For materials scientists, they determine its potential use in polymers and functional coatings.[2] This guide elucidates these properties through a two-pronged approach: first, a theoretical examination using computational modeling, and second, a description of the experimental workflows used for empirical validation.

Part 1: Theoretical and Computational Analysis of Electronic Properties

Before undertaking laboratory experiments, *in silico* analysis provides a powerful, predictive framework for understanding molecular behavior. Density Functional Theory (DFT) is a robust method for modeling the electronic structure of organic molecules, offering insights into orbital energies and electron distribution.^{[4][5]}

Frontier Molecular Orbital (FMO) Analysis

The Highest Occupied Molecular Orbital (HOMO) and Lowest Unoccupied Molecular Orbital (LUMO) are central to a molecule's reactivity and electronic transitions.^[6]

- HOMO: Represents the ability to donate an electron. A higher energy HOMO indicates a better electron donor.
- LUMO: Represents the ability to accept an electron. A lower energy LUMO indicates a better electron acceptor.
- HOMO-LUMO Gap (ΔE): The energy difference between these orbitals is a critical indicator of molecular stability and the energy required for electronic excitation. A smaller gap suggests higher reactivity and a tendency to absorb light at longer wavelengths.^[7]

For **5-ethyl-1H-pyrrole-2-carbaldehyde**, the π -system of the pyrrole ring, influenced by the opposing electronic nature of its substituents, dictates the FMO landscape. The electron-donating ethyl group and the nitrogen lone pair increase the energy of the HOMO, localizing electron density primarily on the pyrrole ring. Conversely, the electron-withdrawing carbaldehyde group lowers the energy of the LUMO, with significant orbital density on the C=O bond and adjacent ring carbons.

Protocol: In Silico DFT Calculation

This protocol describes a standard methodology for performing DFT calculations to determine FMO properties.

- Structure Optimization:
 - Draw the 3D structure of **5-ethyl-1H-pyrrole-2-carbaldehyde** using molecular modeling software.

- Perform a geometry optimization using a standard DFT functional and basis set, such as B3LYP/6-31G(d). This level of theory provides a good balance between accuracy and computational cost for organic molecules.[8]
- Frequency Calculation:
 - Perform a frequency calculation on the optimized structure to confirm it is at a true energy minimum (i.e., no imaginary frequencies).
- Single-Point Energy Calculation:
 - Using the optimized geometry, perform a single-point energy calculation to determine the energies of the molecular orbitals, including HOMO and LUMO.
- Data Analysis:
 - Extract the energy values for the HOMO, LUMO, and calculate the HOMO-LUMO energy gap.
 - Visualize the 3D plots of the HOMO and LUMO to understand their spatial distribution across the molecule.

Predicted Electronic Data and Molecular Electrostatic Potential (MEP)

The MEP map is a visualization of the total electron density distribution, revealing the electrophilic and nucleophilic sites of a molecule. For **5-ethyl-1H-pyrrole-2-carbaldehyde**, the MEP would show:

- Negative Potential (Red/Yellow): Concentrated around the electronegative oxygen atom of the carbaldehyde group, indicating the primary site for electrophilic attack.
- Positive Potential (Blue): Located around the N-H proton, making it the most acidic proton and a potential hydrogen bond donor.
- Neutral/Slightly Negative Potential (Green): Distributed across the pyrrole ring, with the ethyl group contributing to the electron density.

The combination of FMO analysis and the MEP map predicts the molecule's reactivity. Nucleophiles are expected to attack the carbaldehyde carbon, while electrophiles will likely target the electron-rich pyrrole ring.[9]

Parameter	Predicted Value (Representative)	Implication
HOMO Energy	~ -5.5 eV	Moderate electron-donating capability (nucleophilic ring)
LUMO Energy	~ -1.0 eV	Good electron-accepting capability (electrophilic aldehyde)
HOMO-LUMO Gap (ΔE)	~ 4.5 eV	High stability, electronic transitions in the UV region

Note: These values are representative estimates based on DFT studies of similar pyrrole derivatives. Actual values would be determined from the specific DFT calculation described above.

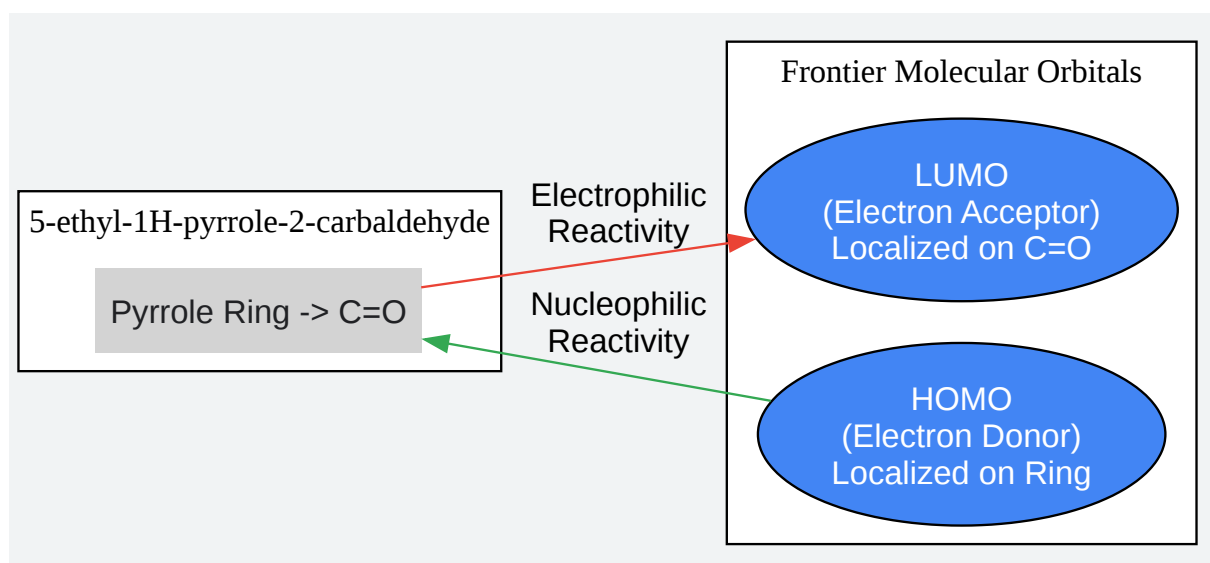

[Click to download full resolution via product page](#)

Caption: Conceptual diagram of Frontier Molecular Orbitals.

Part 2: Experimental Characterization Workflows

The theoretical predictions must be validated through empirical spectroscopic analysis. The following sections detail the standard protocols for characterizing the electronic properties of **5-ethyl-1H-pyrrole-2-carbaldehyde**.

UV-Visible Spectroscopy

Causality: UV-Vis spectroscopy measures the absorption of light resulting from the promotion of electrons from occupied to unoccupied molecular orbitals. For π -conjugated systems like pyrroles, the primary absorption bands correspond to $\pi \rightarrow \pi^*$ transitions. The position of the maximum absorption (λ_{max}) is directly related to the HOMO-LUMO gap; a smaller gap results in a shift to longer wavelengths (a bathochromic or red shift).^[10]

Protocol: UV-Vis Spectrum Acquisition

- Sample Preparation:
 - Prepare a stock solution of **5-ethyl-1H-pyrrole-2-carbaldehyde** of known concentration (e.g., 1 mM) in a UV-grade solvent such as ethanol or acetonitrile.
 - Create a dilute solution (e.g., 10-50 μM) from the stock solution to ensure the absorbance falls within the linear range of the spectrophotometer (typically 0.1-1.0 AU).
- Instrumentation:
 - Use a dual-beam UV-Vis spectrophotometer.
 - Fill one quartz cuvette with the pure solvent to serve as a blank.
 - Fill a second matched quartz cuvette with the sample solution.
- Data Acquisition:
 - Calibrate the instrument by taking a baseline reading with the blank cuvette.
 - Scan the sample across a wavelength range of approximately 200-400 nm.

- Identify the wavelength of maximum absorbance (λ_{max}). Pyrrole-2-carboxaldehyde derivatives typically exhibit strong $\pi \rightarrow \pi^*$ transitions in the 250-300 nm range.^[11]

Nuclear Magnetic Resonance (NMR) Spectroscopy

Causality: NMR spectroscopy probes the local electronic environment of atomic nuclei (^1H , ^{13}C). The chemical shift (δ) of a nucleus is highly sensitive to the shielding or deshielding effects of surrounding electrons. Electron-withdrawing groups deshield nuclei, shifting their signals downfield (higher ppm), while electron-donating groups shield them, causing an upfield shift (lower ppm).

Protocol: ^1H and ^{13}C NMR Spectrum Acquisition

- Sample Preparation:
 - Dissolve 5-10 mg of purified **5-ethyl-1H-pyrrole-2-carbaldehyde** in ~0.6 mL of a deuterated solvent (e.g., CDCl_3 or Acetone- d_6) in a clean NMR tube.
 - Add a small amount of tetramethylsilane (TMS) as an internal standard ($\delta = 0.00$ ppm).
- Data Acquisition:
 - Acquire the ^1H spectrum on a 300 or 400 MHz NMR spectrometer.
 - Acquire a proton-decoupled ^{13}C spectrum.
- Data Analysis:
 - Integrate the ^1H peaks to determine proton ratios.
 - Analyze coupling patterns (J-coupling) to establish connectivity.
 - Assign peaks based on predicted chemical shifts, which are heavily influenced by the electronic effects of the substituents.

Predicted NMR Chemical Shifts (^1H)

Proton	Predicted δ (ppm)	Rationale
Aldehyde (-CHO)	9.5 - 9.7	Strongly deshielded by the electronegative oxygen atom. [12]
N-H	> 10 (broad)	Acidic proton, often broad due to exchange.[13]
Pyrrole H-3	7.0 - 7.2	Deshielded by adjacent aldehyde group.
Pyrrole H-4	6.2 - 6.4	Less deshielded than H-3, shielded by ethyl group.
Ethyl (-CH ₂ -)	2.7 - 2.9	Standard alkyl chemical shift, adjacent to aromatic ring.
Ethyl (-CH ₃)	1.2 - 1.4	Standard alkyl chemical shift.

Note: Predicted shifts are based on data from pyrrole-2-carboxaldehyde and other 5-substituted derivatives.[13][14]

Infrared (IR) Spectroscopy

Causality: IR spectroscopy measures the absorption of infrared radiation corresponding to molecular vibrations. The frequency of a specific vibration (e.g., a bond stretch) is determined by the bond strength and the masses of the atoms. The electronic environment influences bond strength; for example, conjugation can lower the frequency of a C=O stretch.

Protocol: IR Spectrum Acquisition (ATR)

- Sample Preparation:
 - Place a small amount of the solid sample directly onto the crystal of an Attenuated Total Reflectance (ATR) accessory.
- Data Acquisition:
 - Press the sample firmly against the crystal to ensure good contact.

- Acquire a background spectrum of the empty crystal.
- Acquire the sample spectrum over a range of 4000-600 cm^{-1} .
- Data Analysis:
 - Identify the characteristic absorption bands for key functional groups.

Key IR Vibrational Frequencies

Functional Group	Expected Wavenumber (cm^{-1})	Rationale
N-H Stretch	3200 - 3400 (broad)	Characteristic of the pyrrole N-H bond.
C-H Stretch (Aromatic)	3000 - 3100	C-H bonds on the pyrrole ring.
C-H Stretch (Aliphatic)	2850 - 3000	C-H bonds of the ethyl group.
C=O Stretch (Aldehyde)	1650 - 1680	Lower than a typical aldehyde due to conjugation with the pyrrole ring. [15] [16]

Part 3: Synthesis of Electronic Properties and Reactivity

The theoretical and experimental data converge to paint a clear picture of the molecule's reactivity, making it a valuable synthetic intermediate.

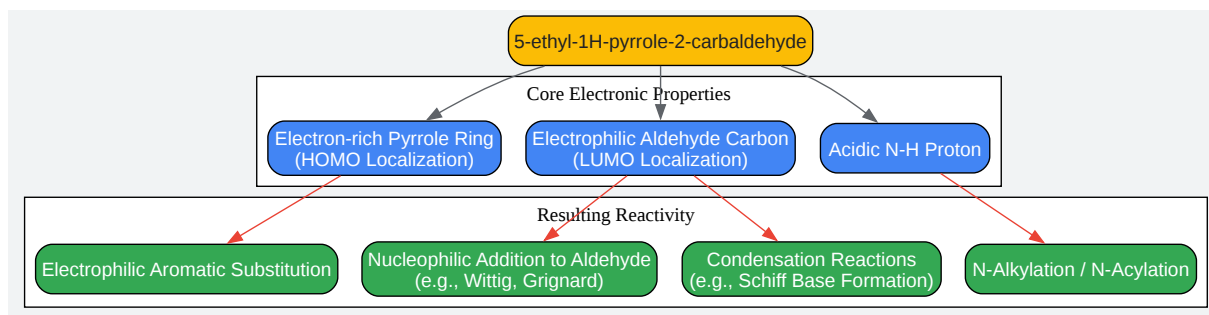

[Click to download full resolution via product page](#)

Need Custom Synthesis?

BenchChem offers custom synthesis for rare earth carbides and specific isotopic labeling.

Email: info@benchchem.com or [Request Quote Online](#).

Sources

- 1. mdpi.com [mdpi.com]
- 2. scent.vn [scent.vn]
- 3. chemimpex.com [chemimpex.com]
- 4. scholarsresearchlibrary.com [scholarsresearchlibrary.com]
- 5. chalcogen.ro [chalcogen.ro]
- 6. Stability, Aromaticity, and Photophysical Behaviors of Macrocyclic Molecules: A Theoretical Analysis - PMC [pmc.ncbi.nlm.nih.gov]
- 7. wuxibiology.com [wuxibiology.com]
- 8. scispace.com [scispace.com]
- 9. (PDF) Eco-friendly synthesis, spectral and computational study of pyrrole-2-carboxaldehyde salicylhydrazone (PCSH) for its application [academia.edu]

- [10. researchgate.net \[researchgate.net\]](https://www.researchgate.net)
- [11. researchgate.net \[researchgate.net\]](https://www.researchgate.net)
- [12. pdf.benchchem.com \[pdf.benchchem.com\]](https://pdf.benchchem.com)
- [13. Pyrrole-2-carboxaldehyde\(1003-29-8\) IR2 spectrum \[chemicalbook.com\]](https://chemicalbook.com)
- [14. Synthesis of 2,2'-bipyrrole-5-carboxaldehydes and their application in the synthesis of B-ring functionalized prodiginines and tambjamines - PMC \[pmc.ncbi.nlm.nih.gov\]](https://pubmed.ncbi.nlm.nih.gov)
- [15. An infrared study of the conformations and association of pyrrole-2-carbaldehydes and pyrrole-2-carboxylates - Journal of the Chemical Society, Perkin Transactions 2 \(RSC Publishing\) \[pubs.rsc.org\]](https://pubs.rsc.org)
- [16. 1H-Pyrrole-2-carboxaldehyde \[webbook.nist.gov\]](https://webbook.nist.gov)
- To cite this document: BenchChem. [Introduction: The Significance of a Functionalized Pyrrole Scaffold]. BenchChem, [2026]. [Online PDF]. Available at: [\[https://www.benchchem.com/product/b2604835/docs#introduction-the-significance-of-a-functionalized-pyrrole-scaffold\]](https://www.benchchem.com/product/b2604835/docs#introduction-the-significance-of-a-functionalized-pyrrole-scaffold)

Disclaimer & Data Validity:

The information provided in this document is for Research Use Only (RUO) and is strictly not intended for diagnostic or therapeutic procedures. While BenchChem strives to provide accurate protocols, we make no warranties, express or implied, regarding the fitness of this product for every specific experimental setup.

Technical Support: The protocols provided are for reference purposes. Unsure if this reagent suits your experiment?

Need Industrial/Bulk Grade? [Request Custom Synthesis Quote](#)

BenchChem

Our mission is to be the trusted global source of essential and advanced chemicals, empowering scientists and researchers to drive progress in science and industry.

Contact

Address: 3281 E Guasti Rd
Ontario, CA 91761, United States
Phone: (601) 213-4426
Email: info@benchchem.com

Contact our Ph.D. Support Team for a compatibility check