

# Technical Support Center: Ginkgolic Acid (C17:2) Stability & Handling

**Author:** BenchChem Technical Support Team. **Date:** May 2026

## Compound of Interest

Compound Name: Ginkgolic acid 17:2

CAS No.: 102811-39-2

Cat. No.: B2594678

[Get Quote](#)

## Ticket Subject: Minimizing Degradation of Heptadecadienyl Salicylic Acid (GA 17:2)

Assigned Specialist: Senior Application Scientist, Lipophilic Standards Division  
Urgency: High (Compound is chemically labile and cytotoxic)

## Executive Summary: The C17:2 Stability Paradox

Ginkgolic Acid C17:2 (2-[(8Z,11Z)-heptadeca-8,11-dienyl]salicylic acid) represents a unique challenge in natural product chemistry. Unlike its saturated analogs (C13:0, C15:0), the C17:2 variant contains a di-unsaturated alkyl chain.

From a chemical stability standpoint, this specific unsaturation profile creates two critical vulnerabilities:

- **Oxidative Susceptibility:** The double bonds serve as attack sites for Reactive Oxygen Species (ROS), leading to hydroperoxide formation.

- Thermal Decarboxylation: The carboxyl group at the ortho position is thermally unstable, readily ejecting CO<sub>2</sub> to form Ginkgol 17:2 (a degradation product often mistaken for the parent compound in HPLC).

This guide provides the protocols necessary to maintain the integrity of GA 17:2 for quantitative analysis and biological assays.

## The Stability Matrix: Environmental Control

The following table summarizes the critical control points (CCPs) for preventing degradation.

Factor	Critical Threshold	Mechanism of Degradation	Mitigation Strategy
Temperature	> -20°C (Long-term) > +40°C (Acute)	Decarboxylation: Heat catalyzes the loss of the carboxyl group, converting the acid to a phenol (Ginkgol).	Store solid at -80°C. Working aliquots at -20°C. Never heat to dissolve.
Oxygen	Atmospheric O <sub>2</sub>	Auto-oxidation: The diene chain undergoes radical chain reactions, forming epoxides or cleaving the chain.	Argon/Nitrogen Overlay is mandatory after every opening.
Light	UV/Visible (Blue)	Photo-isomerization: Cis (Z) double bonds can flip to Trans (E), altering biological binding affinity.	Use Amber Glass exclusively. Wrap clear vessels in aluminum foil.
Solvent	Protic vs. Aprotic	Solvolysis/Hygroscopicity: DMSO absorbs water, causing precipitation. Methanol evaporates, altering concentration.	Use Anhydrous DMSO for bio-assays; Methanol for HPLC (freshly prepared).

[1]

## Visualizing the Threat: Degradation Pathways

The following diagram illustrates the specific chemical risks associated with the C17:2 structure.

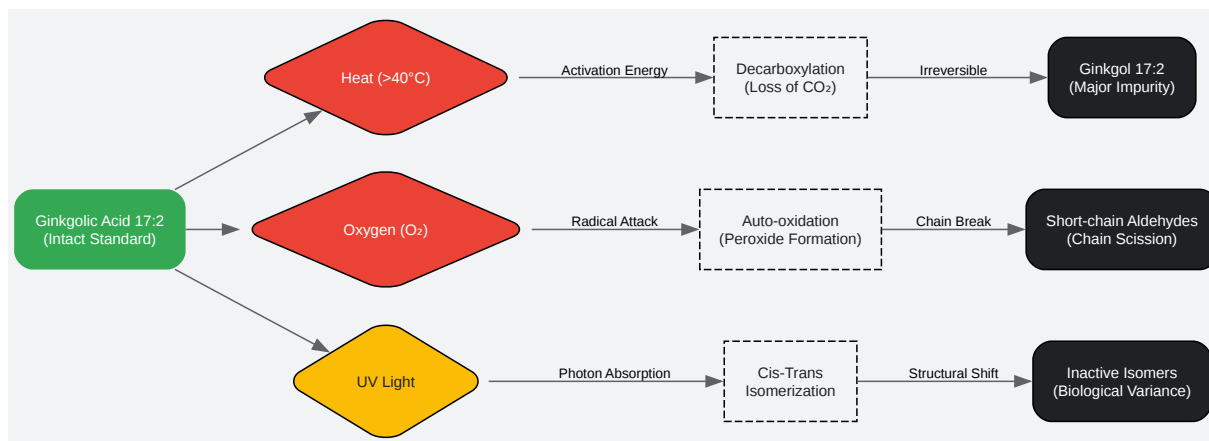

[Click to download full resolution via product page](#)

Figure 1: Mechanistic pathways of **Ginkgolic Acid 17:2** degradation leading to specific impurity profiles.

## Solvent Systems: The "User Error" Zone

Most stability issues arise not during storage of the solid, but after reconstitution.

### Scenario A: Biological Assays (Cell Culture)

- Recommended Solvent: Dimethyl Sulfoxide (DMSO).
- The Risk: DMSO is hygroscopic. It pulls moisture from the air.
- The Consequence: GA 17:2 is lipophilic. As water content in DMSO rises, GA 17:2 precipitates out of solution (often invisibly), leading to "false negative" toxicity results.
- Protocol: Use single-use aliquots. Do not freeze/thaw DMSO stocks more than twice.

### Scenario B: Analytical Chemistry (HPLC/LC-MS)

- Recommended Solvent: Methanol (MeOH).
- The Risk: Volatility.
- The Consequence: Evaporation increases the concentration, leading to "false high" quantification.
- Protocol: Prepare fresh daily. Store in autosampler vials with pre-slit PTFE/Silicone septa to prevent vacuum formation while minimizing evaporation.

## Troubleshooting Guide (FAQ)

Q1: My HPLC chromatogram shows a new peak eluting after GA 17:2. What is it?

- Diagnosis: This is likely Ginkgol 17:2.[\[2\]](#)[\[3\]](#)
- Cause: Thermal degradation.[\[4\]](#)[\[5\]](#) Did you use a heated sonicator to dissolve the solid? Or was the column oven temperature set  $>40^{\circ}\text{C}$ ?
- Fix: Lower column temperature to 25-30°C. Dissolve standards using a vortex mixer, not heated sonication.

Q2: The solid standard has turned from off-white to yellow/brown.

- Diagnosis: Oxidative polymerization.
- Cause: The container was likely not purged with inert gas after the last use. The di-unsaturated chain has oxidized.
- Fix: The standard is compromised. Discard. For the replacement, ensure you use an Argon flush system.

Q3: Can I store the standard in plastic (polypropylene) tubes?

- Diagnosis: Surface adsorption.
- Cause: Alkylphenols are highly lipophilic and can "stick" to plastic walls, effectively lowering the concentration in the solution.

- Fix: Use Silanized Glass or standard Amber Glass vials. Avoid plastics for long-term storage.

## Protocol: The "Golden Standard" Handling Workflow

Follow this strictly to ensure reproducibility between experiments.

### Phase 1: Receipt & Initial Storage

- Inspection: Upon receipt, verify the vial is sealed and the desiccant is active (if present).
- Deep Freeze: Immediately place the solid vial at  $-80^{\circ}\text{C}$ . Do not store at  $-20^{\circ}\text{C}$  for periods exceeding 1 month.

### Phase 2: Reconstitution (Creating the Master Stock)

- Equilibration: Allow the vial to warm to room temperature inside a desiccator (20 mins). Opening a cold vial causes condensation, which degrades the acid.
- Weighing: Weigh quickly in a low-light environment.
- Solvation: Dissolve in degassed Methanol or Anhydrous DMSO.
- Inert Gas: Gently blow a stream of Argon (preferred over Nitrogen due to density) into the headspace of the master vial for 10 seconds.
- Seal: Close tightly with a Parafilm overwrap.

### Phase 3: Aliquoting Strategy

To avoid freeze-thaw cycles, create "Single-Shot" aliquots.

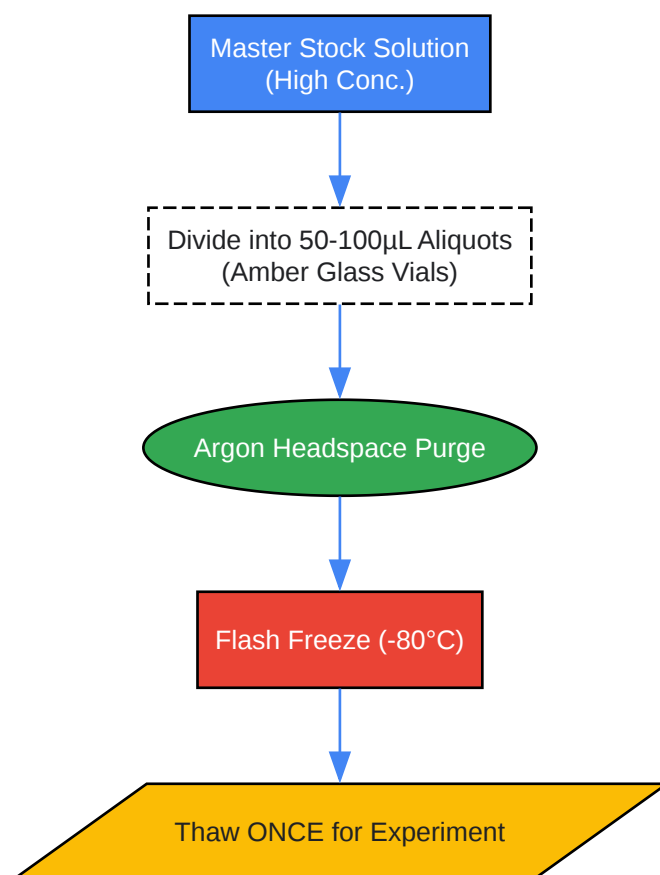

[Click to download full resolution via product page](#)

Figure 2: The "Single-Shot" Aliquoting Workflow to prevent freeze-thaw degradation.

## References

- Yang, X. M., et al. (2014).[4][5] "Thermal stability of ginkgolic acids from Ginkgo biloba and the effects of ginkgol C17:1 on the apoptosis and migration of SMMC7721 cells." *Fitoterapia*.
  - Relevance: Establishes the thermal degradation threshold (decarboxylation)
- van Beek, T. A., & Wintermans, M. S. (2001). "Determination of Ginkgolic Acids in Ginkgo biloba L. Leaves and Extracts." *Journal of Chromatography A*.
  - Relevance: Defines the chromatographic behavior and separation of C15:1 vs C17:2, and the importance of preventing peak shifting.
- Hecker, H., et al. (2002). "Toxicology of Ginkgolic Acids." *Toxicology*.

- Relevance: Highlights the cytotoxicity and allergenic potential, reinforcing the safety protocols and PPE requirements during handling.
- PubChem Compound Summary. (n.d.). "**Ginkgolic acid 17:2**." [2][3][6] National Center for Biotechnology Information.
  - Relevance: Verifies chemical structure (di-unsatur

### Need Custom Synthesis?

BenchChem offers custom synthesis for rare earth carbides and specific isotopic labeling.

Email: [info@benchchem.com](mailto:info@benchchem.com) or [Request Quote Online](#).

## Sources

- [1. researchgate.net \[researchgate.net\]](#)
- [2. biosynth.com \[biosynth.com\]](#)
- [3. Ginkgolic acid 17:2 | C<sub>24</sub>H<sub>36</sub>O<sub>3</sub> | CID 101926662 - PubChem \[pubchem.ncbi.nlm.nih.gov\]](#)
- [4. Thermal stability of ginkgolic acids from Ginkgo biloba and the effects of ginkgol C17:1 on the apoptosis and migration of SMMC7721 cells - PubMed \[pubmed.ncbi.nlm.nih.gov\]](#)
- [5. Reducing toxic constituents of ginkgolic acid content and improving bioactive flavonoid content from Ginkgo biloba leaves by high-temperature pretreatment processing - PMC \[pmc.ncbi.nlm.nih.gov\]](#)
- [6. researchgate.net \[researchgate.net\]](#)
- To cite this document: BenchChem. [Technical Support Center: Ginkgolic Acid (C17:2) Stability & Handling]. BenchChem, [2026]. [Online PDF]. Available at: [\[https://www.benchchem.com/product/b2594678/docs#technical-support-center-ginkgolic-acid-c17-2-stability-handling\]](https://www.benchchem.com/product/b2594678/docs#technical-support-center-ginkgolic-acid-c17-2-stability-handling)

---

### Disclaimer & Data Validity:

The information provided in this document is for Research Use Only (RUO) and is strictly not intended for diagnostic or therapeutic procedures. While BenchChem strives to provide accurate protocols, we make no warranties, express or implied, regarding the fitness of this product for every specific experimental setup.

**Technical Support:** The protocols provided are for reference purposes. Unsure if this reagent suits your experiment?

**Need Industrial/Bulk Grade?** [Request Custom Synthesis Quote](#)

## BenchChem

Our mission is to be the trusted global source of essential and advanced chemicals, empowering scientists and researchers to drive progress in science and industry.

### Contact

Address: 3281 E Guasti Rd  
Ontario, CA 91761, United States  
Phone: (601) 213-4426  
Email: [info@benchchem.com](mailto:info@benchchem.com)

[Contact our Ph.D. Support Team for a compatibility check](#)