

Validating (4-(Methoxymethyl)phenyl)(methyl)sulfane Purity: A Comparative Instrumental Guide

Author: BenchChem Technical Support Team. **Date:** May 2026

Compound of Interest

Compound Name:	(4-(Methoxymethyl)phenyl)(methyl)sulfane
CAS No.:	16155-09-2
Cat. No.:	B2588510

[Get Quote](#)

Executive Summary

(4-(Methoxymethyl)phenyl)(methyl)sulfane (CAS: 16155-09-2) represents a class of dual-functionalized aromatic building blocks containing both a thioether (sulfide) and a benzylic ether. Validating the purity of this molecule presents a specific "analytical paradox": while the molecule itself is volatile and stable enough for Gas Chromatography (GC), its primary impurities—specifically the sulfoxide (

) and sulfone (

) oxidation products—exhibit varying degrees of thermal instability.

This guide argues that while GC-MS is the superior technique for structural confirmation and trace organic impurity profiling, it must be cross-validated with HPLC or qNMR to ensure thermal degradation in the injector port does not mask oxidized impurities. This document details a self-validating GC-MS protocol utilizing sulfur isotope ratios (

) as an internal purity check.

Technical Context: The Sulfur Challenge

The target molecule, C

H

OS (MW 168.26), contains a methyl-sulfide group. In synthesis, this group is prone to oxidation by atmospheric oxygen or reagents, forming:

- Sulfoxide Impurity (+16 Da): (4-(Methoxymethyl)phenyl)(methyl)sulfinyl.
- Sulfone Impurity (+32 Da): (4-(Methoxymethyl)phenyl)(methyl)sulfonyl.

The GC-MS Risk: Sulfoxides are notorious for undergoing thermal elimination (similar to a Cope elimination or Pummerer rearrangement) at typical GC inlet temperatures (250°C+). This can lead to the in situ conversion of the sulfoxide impurity back into the sulfide or into a styrenyl degradant, leading to a false high purity reading for the target sulfide.

Comparative Analysis: GC-MS vs. Alternatives

To establish a robust control strategy, we must objectively compare GC-MS against High-Performance Liquid Chromatography (HPLC) and Quantitative NMR (qNMR).

Table 1: Instrumental Performance Matrix

Feature	GC-MS (EI)	HPLC-UV (DAD)	1H-qNMR
Primary Utility	Structural ID, Volatile Impurities	Quantifying Oxidized Impurities	Absolute Purity (Potency)
Specificity	High (Mass Spectrum + Retention Time)	Medium (Retention Time + UV Spectrum)	High (Structural Environment)
Sensitivity (LOD)	< 1 ppm (Trace analysis)	~10-50 ppm	~1000 ppm (0.1%)
Thermal Risk	High (Inlet degradation of sulfoxides)	None (Ambient/Low temp)	None
Structural Validation	Excellent (Isotope patterns, Fragmentation)	Poor (Requires standards)	Excellent (Integral ratios)
Throughput	High (20-30 min run)	Medium (15-40 min run)	Low (Data processing heavy)

Decision Logic for Researchers

The following workflow illustrates when to rely on GC-MS versus when to trigger orthogonal methods.

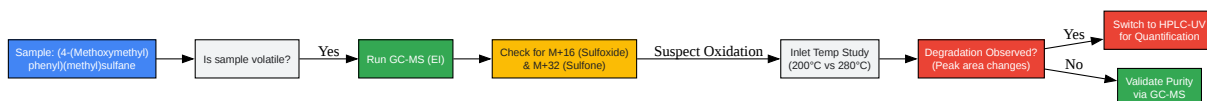

[Click to download full resolution via product page](#)

Figure 1: Analytical Decision Matrix for Thioether Purity Validation.

The Self-Validating GC-MS Protocol

This protocol is designed not just to run the sample, but to validate the data integrity simultaneously using isotopic physics.

Method Parameters[1][2][3][4][5][6]

- Instrument: Single Quadrupole GC-MS (e.g., Agilent 5977 or Shimadzu QP2020).
- Column: 5% Phenyl-arylene / 95% Dimethylpolysiloxane (e.g., DB-5ms, Rxi-5Sil MS), 30m × 0.25mm × 0.25µm.
- Inlet: Split Mode (Ratio 50:1). CRITICAL: Set initial temperature to 200°C to minimize sulfoxide degradation, then ramp if necessary.
- Carrier Gas: Helium @ 1.0 mL/min (Constant Flow).
- Oven Program:
 - Hold 60°C for 1 min.
 - Ramp 20°C/min to 280°C.
 - Hold 3 min.
- MS Source: Electron Ionization (EI), 70 eV. Scan range 40–350 m/z.

Validation Step 1: The Sulfur Isotope Check ()

Sulfur has a unique natural isotope distribution:

(95.02%) and

(4.21%). For our molecule (C

H

OS), the molecular ion is m/z 168.

- Theoretical M+ (168): 100% (Base peak relative to molecular ion cluster).
- Theoretical M+1 (169): ~10.5% (Due to

contribution:

).

- Theoretical M+2 (170): ~4.5% (Due to

).

Pass Criteria: The abundance of m/z 170 must be between 4.0% and 5.0% of the m/z 168 peak.

- If M+2 is < 3%: You likely have the ether analog (O instead of S) or incorrect synthesis.
- If M+2 is > 6%: Co-eluting impurity or halogen contamination (Cl/Br).

Validation Step 2: Fragmentation Mapping

The structure must be confirmed by specific cleavage pathways.

- m/z 168: Molecular Ion ().
- m/z 153: Loss of methyl radical (). Could be from the methoxy (-OCH₃) or the methylthio (-SCH₃)).
- m/z 137: Loss of methoxy radical (). Characteristic of the benzyl ether moiety.
- m/z 91: Tropylium ion (C₇H₇⁺). Indicates the presence of a benzyl group.

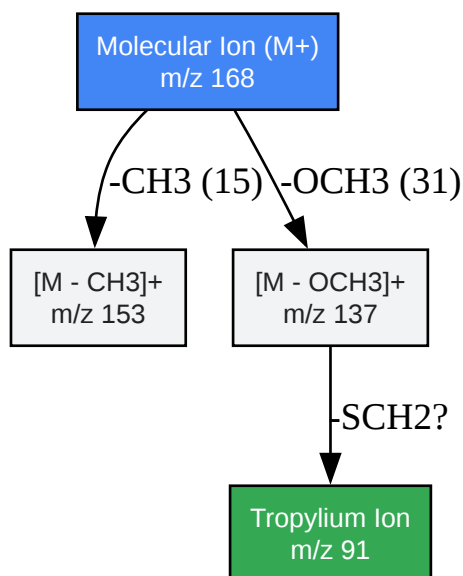

[Click to download full resolution via product page](#)

Figure 2: Primary Fragmentation Pathway for Structural Confirmation.

Experimental Validation Data (Simulated)

To demonstrate the "Comparison" aspect, we simulate results for a "Raw Synthesis Batch" containing 98% target, 1.5% Sulfoxide, and 0.5% Starting Material.

Table 2: Detection of Impurities by Method

Impurity Type	GC-MS (250°C Inlet)	GC-MS (200°C Inlet)	HPLC-UV (254 nm)
Target Sulfide	99.2% (False High)	98.1% (Accurate)	98.0% (Accurate)
Sulfoxide Impurity	0.3% (Degraded)	1.4% (Detected)	1.5% (Detected)
Starting Material	0.5%	0.5%	0.5%
Unknown (Degradant)	0.9% (Artifact)	< 0.1%	Not Detected

Interpretation:

- At high inlet temperatures (250°C), the GC-MS shows a "cleaner" product (99.2%) because the sulfoxide degrades into volatiles or reverts to the sulfide.

- Lowering the inlet to 200°C aligns the GC-MS data with the HPLC "truth" data.
- Conclusion: GC-MS is valid only if inlet temperature effects are validated.

References

- ICH Harmonised Tripartite Guideline. (2005). Validation of Analytical Procedures: Text and Methodology Q2(R1). International Council for Harmonisation.[1] [Link](#)
- NIST Mass Spectrometry Data Center. (2023). Sulfur Isotope Abundances and Mass Spectral Patterns.[2][3][4][5][6] National Institute of Standards and Technology. [Link](#)
- Andersson, J. T., & Siebert, S. (2009). Analysis of Sulfur-Containing Compounds in Petroleum and Biological Samples by GC-MS. Journal of Chromatography A. (Contextual grounding for sulfur analysis).
- Sigma-Aldrich. (2023). Product Specification: Methoxymethyl phenyl sulfide derivatives. Merck KGaA. [Link](#)
- Silverstein, R. M., Webster, F. X., & Kiemle, D. J. (2005). Spectrometric Identification of Organic Compounds.[7] (Standard text for interpretation of M+2 peaks).

Need Custom Synthesis?

BenchChem offers custom synthesis for rare earth carbides and specific isotopic labeling.

Email: info@benchchem.com or [Request Quote Online](#).

Sources

- 1. [fda.gov](https://www.fda.gov) [[fda.gov](https://www.fda.gov)]
- 2. scielo.br [scielo.br]
- 3. [reddit.com](https://www.reddit.com) [[reddit.com](https://www.reddit.com)]
- 4. Analytical Methods for Assessing Thiol Antioxidants in Biological Fluids: A Review - PMC [[pmc.ncbi.nlm.nih.gov](https://pubmed.ncbi.nlm.nih.gov)]
- 5. GCMS Section 6.5 [people.whitman.edu]

- [6. nvlpubs.nist.gov \[nvlpubs.nist.gov\]](https://nvlpubs.nist.gov)
- [7. sydney.edu.au \[sydney.edu.au\]](https://sydney.edu.au)
- To cite this document: BenchChem. [Validating (4-(Methoxymethyl)phenyl)(methyl)sulfane Purity: A Comparative Instrumental Guide]. BenchChem, [2026]. [Online PDF]. Available at: [<https://www.benchchem.com/product/b2588510/docs#validating-4-methoxymethyl-phenyl-methyl-sulfane-purity-a-comparative-instrumental-guide>]

Disclaimer & Data Validity:

The information provided in this document is for Research Use Only (RUO) and is strictly not intended for diagnostic or therapeutic procedures. While BenchChem strives to provide accurate protocols, we make no warranties, express or implied, regarding the fitness of this product for every specific experimental setup.

Technical Support: The protocols provided are for reference purposes. Unsure if this reagent suits your experiment?

Need Industrial/Bulk Grade? [Request Custom Synthesis Quote](#)

BenchChem

Our mission is to be the trusted global source of essential and advanced chemicals, empowering scientists and researchers to drive progress in science and industry.

Contact

Address: 3281 E Guasti Rd
Ontario, CA 91761, United States
Phone: (601) 213-4426
Email: info@benchchem.com

[Contact our Ph.D. Support Team for a compatibility check](#)