

Application Notes and Protocols for GW6471 Vehicle Solution for Intraperitoneal Injection

Author: BenchChem Technical Support Team. **Date:** April 2026

Compound of Interest

Compound Name:	GW6471
CAS No.:	436159-64-7; 880635-03-0
Cat. No.:	B2584060

[Get Quote](#)

For Researchers, Scientists, and Drug Development Professionals

These application notes provide detailed protocols for the preparation of **GW6471**, a potent PPAR α antagonist, for intraperitoneal (i.p.) injection in research animals. The information is intended to guide researchers in formulating a stable and effective vehicle solution for in vivo studies.

Introduction

GW6471 is a selective antagonist of Peroxisome Proliferator-Activated Receptor alpha (PPAR α) with an IC₅₀ of 0.24 μ M.[1][2] It functions by enhancing the binding affinity of the PPAR α ligand-binding domain to co-repressor proteins such as SMRT and NCoR.[1] Due to its hydrophobic nature, **GW6471** is insoluble in water, necessitating the use of a suitable vehicle for aqueous-based delivery methods like intraperitoneal injection. This document outlines several vehicle formulations and preparation protocols based on published research.

Data Presentation

GW6471 Solubility

The solubility of **GW6471** in various common laboratory solvents is summarized below. It is crucial to use fresh, anhydrous solvents, as the presence of moisture can significantly reduce solubility, particularly for DMSO.[2]

Solvent	Concentration (mg/mL)	Molar Concentration (mM)	Notes
DMSO	16.67 - 100	26.9 - 161.37	Sonication or warming may be required.[1][2] [3] Use of fresh, moisture-free DMSO is recommended.[2]
DMF	20	~32.27	-
Ethanol	10 - 20	~16.14 - 32.27	-
DMF:PBS (pH 7.2) (1:2)	0.33	~0.53	Limited aqueous solubility.
10% DMSO + 90% Saline	0.25	0.4	A common final formulation for injection.[1]

Molecular Weight of **GW6471**: 619.67 g/mol [1][3]

Recommended Vehicle Formulations for Intraperitoneal Injection

Several vehicle compositions have been successfully used for the intraperitoneal administration of **GW6471** in animal models. The choice of vehicle may depend on the desired final concentration, dosing volume, and experimental model.

Vehicle Composition	Final GW6471 Concentration	Animal Model	Reference
10% DMSO in Saline	0.25 mg/mL	Mice	[1]
4% DMSO in PBS	Not specified (dose of 20 mg/kg)	Mice	[4]
10% DMSO, 20% SBE- β -CD in Saline	2.08 mg/mL (working solution)	Mice	[3]
5% DMSO, 40% PEG300, 5% Tween80, 50% ddH2O	2.5 mg/mL (working solution)	Not specified	[2]
5% DMSO in Corn Oil	5 mg/mL (working solution)	Not specified	[2]

Experimental Protocols

The following are detailed protocols for preparing **GW6471** solutions for intraperitoneal injection.

Protocol 1: DMSO and Saline/PBS Vehicle

This is a straightforward method for preparing a low-concentration solution of **GW6471**.

Materials:

- **GW6471** powder
- Anhydrous Dimethyl sulfoxide (DMSO)
- Sterile Saline (0.9% NaCl) or Phosphate-Buffered Saline (PBS)
- Sterile, light-protected microcentrifuge tubes or vials

Procedure:

- Prepare a Stock Solution:
 - Accurately weigh the desired amount of **GW6471** powder.
 - Dissolve the **GW6471** in anhydrous DMSO to create a concentrated stock solution (e.g., 10 mg/mL). Sonication or gentle warming (up to 60°C) may be necessary to fully dissolve the compound.[3] Ensure the solution is clear.
- Prepare the Final Dosing Solution:
 - On the day of injection, dilute the DMSO stock solution with sterile saline or PBS to the desired final concentration.
 - For a 10% DMSO in saline solution, add 1 part of the DMSO stock solution to 9 parts of saline. For a 4% DMSO in PBS solution, add 1 part of a 40% DMSO stock to 9 parts of PBS, or adjust volumes accordingly.
 - Vortex the solution gently to mix thoroughly. The final solution should be clear. If precipitation occurs, the final concentration may be too high for this vehicle.

Protocol 2: Solubilization with SBE- β -CD

This protocol utilizes sulfobutyl ether beta-cyclodextrin (SBE- β -CD) as a solubilizing agent, which can be useful for achieving higher concentrations.

Materials:

- **GW6471** powder
- Anhydrous DMSO
- SBE- β -CD
- Sterile Saline
- Sterile, light-protected containers

Procedure:

- Prepare a 20% SBE- β -CD in Saline Solution:
 - Dissolve 2 g of SBE- β -CD powder in 10 mL of sterile saline.
 - Stir until the powder is completely dissolved and the solution is clear. This solution can be stored at 4°C for up to one week.[3]
- Prepare a **GW6471** Stock Solution in DMSO:
 - Prepare a concentrated stock solution of **GW6471** in DMSO (e.g., 20.8 mg/mL).[3]
- Prepare the Final Dosing Solution:
 - To prepare a 1 mL working solution, add 100 μ L of the **GW6471** DMSO stock solution to 900 μ L of the 20% SBE- β -CD in saline solution.[3]
 - Mix thoroughly until a clear, suspended solution is formed. This formulation is suitable for both oral and intraperitoneal administration.[3]

Protocol 3: Co-solvent Vehicle with PEG300 and Tween80

This method uses a combination of solvents to maintain the solubility of **GW6471** in an aqueous-based final solution.

Materials:

- **GW6471** powder
- Anhydrous DMSO
- PEG300
- Tween80
- Sterile deionized water (ddH₂O)
- Sterile, light-protected containers

Procedure:

- Prepare a **GW6471** Stock Solution in DMSO:
 - Prepare a high-concentration stock solution of **GW6471** in DMSO (e.g., 50 mg/mL).[2]
- Prepare the Final Dosing Solution (for 1 mL):
 - To 400 μ L of PEG300, add 50 μ L of the 50 mg/mL **GW6471** DMSO stock solution.
 - Mix until the solution is clear.
 - Add 50 μ L of Tween80 to the mixture and mix until clear.
 - Add 500 μ L of ddH₂O to bring the final volume to 1 mL.
 - Mix thoroughly. It is recommended to use this solution immediately for optimal results.[2]

Mandatory Visualizations

Signaling Pathway of GW6471

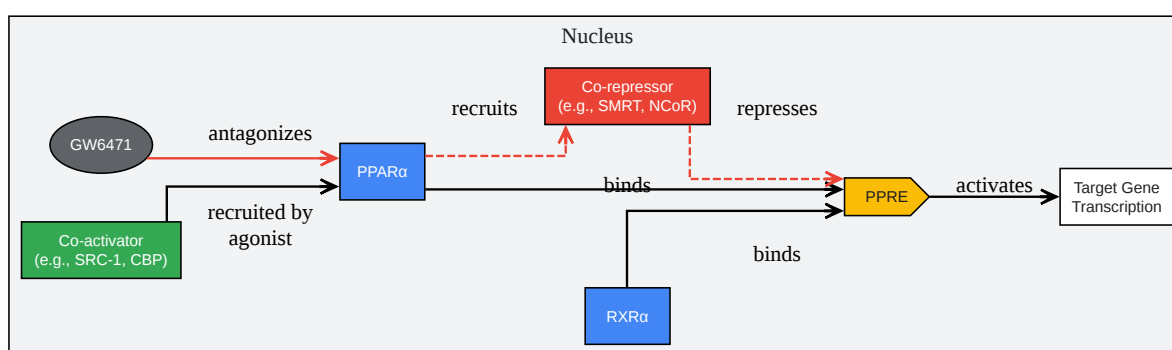

[Click to download full resolution via product page](#)

Caption: Mechanism of PPAR α antagonism by **GW6471**.

Experimental Workflow for Vehicle Preparation (Protocol 1)

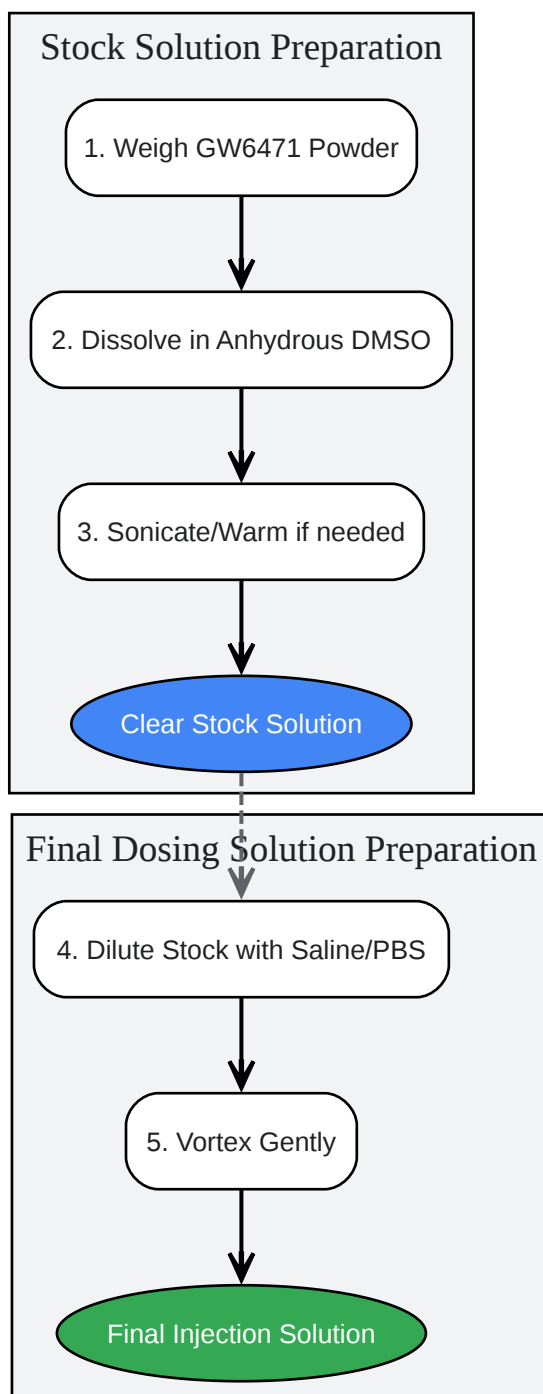

[Click to download full resolution via product page](#)

Need Custom Synthesis?

BenchChem offers custom synthesis for rare earth carbides and specific isotopic labeling.

Email: info@benchchem.com or [Request Quote Online](#).

References

- 1. GW6471 | PPAR α antagonist | TargetMol [targetmol.com]
- 2. selleckchem.com [selleckchem.com]
- 3. medchemexpress.com [medchemexpress.com]
- 4. researchgate.net [researchgate.net]
- To cite this document: BenchChem. [Application Notes and Protocols for GW6471 Vehicle Solution for Intraperitoneal Injection]. BenchChem, [2026]. [Online PDF]. Available at: [<https://www.benchchem.com/product/b2584060/docs#application-notes-and-protocols-for-gw6471-vehicle-solution-for-intraperitoneal-injection>]

Disclaimer & Data Validity:

The information provided in this document is for Research Use Only (RUO) and is strictly not intended for diagnostic or therapeutic procedures. While BenchChem strives to provide accurate protocols, we make no warranties, express or implied, regarding the fitness of this product for every specific experimental setup.

Technical Support: The protocols provided are for reference purposes. Unsure if this reagent suits your experiment?

Need Industrial/Bulk Grade? [Request Custom Synthesis Quote](#)

BenchChem

Our mission is to be the trusted global source of essential and advanced chemicals, empowering scientists and researchers to drive progress in science and industry.

Contact

Address: 3281 E Guasti Rd

Ontario, CA 91761, United States

Phone: (601) 213-4426

Email: info@benchchem.com

[Contact our Ph.D. Support Team for a compatibility check](#)