

Technical Support Center: Troubleshooting Low Yields in Suzuki Coupling with Polyhalogenated Substrates

Author: BenchChem Technical Support Team. **Date:** April 2026

Compound of Interest

Compound Name:	6-Bromo-2,4-difluoro-3-iodobenzaldehyde
CAS No.:	2244721-25-1
Cat. No.:	B2579427

[Get Quote](#)

Welcome to the technical support center for Suzuki-Miyaura cross-coupling reactions. This guide is specifically designed for researchers, scientists, and drug development professionals who are encountering challenges with low yields when using polyhalogenated substrates. As a Senior Application Scientist, my goal is to provide you with not just procedural steps, but also the underlying scientific reasoning to empower you to make informed decisions in your experimental design.

This resource is structured as a series of frequently asked questions (FAQs) that directly address common and complex issues encountered in the lab. We will delve into the intricacies of catalyst systems, reaction conditions, and substrate-specific challenges to help you optimize your reactions for maximal yield and selectivity.

Frequently Asked Questions (FAQs)

General Issues & Catalyst System

Question 1: My Suzuki coupling reaction with a di- or tri-halogenated arene is giving very low yields or has stalled completely. Where should I start my troubleshooting?

Low yield or incomplete conversion is a frequent challenge, often pointing to issues with the catalyst system, reaction conditions, or reagent purity.^[1] Here's a systematic approach to diagnose the problem:

- **Catalyst Activity:** The heart of the Suzuki reaction is the palladium catalyst. Its activity can be compromised by several factors.
 - **Catalyst Oxidation:** The active Pd(0) species is susceptible to oxidation by atmospheric oxygen. Ensure your reaction is thoroughly degassed and maintained under an inert atmosphere (Argon or Nitrogen).^[1] Oxygen can not only deactivate the catalyst but also promote the unwanted homocoupling of boronic acids.^[2]
 - **Ligand Integrity:** Phosphine ligands, commonly used in Suzuki couplings, can be oxidized by air, which prevents them from coordinating effectively with the palladium center.^[1] It is crucial to use fresh ligands or those that have been stored properly under an inert atmosphere.
 - **Pre-catalyst Activation:** Many reactions use stable Pd(II) pre-catalysts that must be reduced in situ to the active Pd(0) species. If this reduction is inefficient, the catalytic cycle will not initiate properly.
- **Reaction Conditions:**
 - **Temperature:** While many Suzuki couplings require heat, excessive temperatures can accelerate catalyst decomposition, leading to the formation of palladium black.^[1] If you observe significant precipitation, consider lowering the reaction temperature, even if it necessitates a longer reaction time.^[1]
 - **Base Selection:** The base is critical for activating the boronic acid in the transmetalation step.^{[3][4]} Its choice is highly dependent on the substrates and solvent. An inappropriate base can lead to a sluggish reaction.
- **Reagent Quality:**

- Solvent and Base Purity: Ensure that your solvents are anhydrous (if the protocol demands it) and have been properly degassed. The purity of the base is also paramount. [\[1\]](#)
- Boronic Acid Quality: Boronic acids can undergo protodeboronation, especially at high temperatures, which reduces the amount of active nucleophile. [\[5\]](#) Use high-purity boronic acids.

Question 2: I'm observing significant formation of palladium black in my reaction with a polychlorinated substrate. What's causing this and how can I prevent it?

The formation of palladium black is a visual indicator of catalyst deactivation, where the soluble palladium complexes aggregate into insoluble, catalytically inactive palladium metal. [\[1\]](#) This is a common issue, especially in challenging couplings involving less reactive aryl chlorides.

Causality: This precipitation occurs when the palladium center becomes coordinatively unsaturated, making it prone to aggregation. [\[1\]](#) High reaction temperatures can exacerbate this issue by accelerating the rate of decomposition. [\[1\]](#)

Troubleshooting Steps:

- Optimize Ligand-to-Palladium Ratio: An insufficient amount of ligand is a primary cause of catalyst aggregation. Ensure you are using an appropriate ligand-to-palladium ratio, which is typically between 1:1 and 4:1, depending on the specific ligand and catalyst used. [\[1\]](#)
- Select a More Robust Ligand: Some ligands form more stable complexes with palladium. Bulky, electron-rich phosphine ligands (e.g., Buchwald's biaryl phosphine ligands) or N-heterocyclic carbene (NHC) ligands are known to provide greater stability to the palladium center, thus preventing precipitation. [\[1\]](#)[\[6\]](#)
- Control the Temperature: As mentioned, high temperatures can accelerate catalyst decomposition. It is often beneficial to run the reaction at a lower temperature for a longer duration. [\[1\]](#)
- Ensure Efficient Mixing: Inadequate stirring can create localized high concentrations of reagents, which can contribute to catalyst decomposition. [\[1\]](#)

Selectivity with Polyhalogenated Substrates

Question 3: I am trying to achieve mono-functionalization of a dihalogenated arene, but I'm getting a mixture of mono- and di-substituted products, with the di-substituted product often dominating. How can I improve selectivity for the mono-coupled product?

Controlling the degree of functionalization in polyhalogenated substrates is a significant challenge.^[7] The preference for exhaustive functionalization is often linked to the behavior of the catalyst after the first coupling event.^[7]

Mechanistic Insight: After the initial cross-coupling, the palladium catalyst can remain coordinated to the π -system of the newly formed mono-coupled product. The selectivity between mono- and di-functionalization is determined by the relative rates of two competing processes: the decomplexation of the palladium catalyst from the mono-coupled product versus a second oxidative addition at a remaining halogen site.^[7]

With certain catalyst systems, particularly those involving bulky ligands, the palladium complex may not readily dissociate. Instead, a second molecule (like the dihaloarene starting material or a coordinating solvent) is required to displace the palladium from the mono-coupled product.^[7] If this displacement is slow, the catalyst is more likely to undergo a second oxidative addition on the same molecule, leading to the di-substituted product.^[7]

Strategies to Enhance Mono-selectivity:

- **Ligand Choice:** The steric bulk of the ligand plays a crucial role. Extremely bulky ligands can hinder the displacement of the palladium catalyst from the mono-coupled product, thereby favoring a second intramolecular oxidative addition.^[7] Consider screening less sterically hindered ligands.
- **Use of Coordinating Additives:** Small, coordinating additives or solvents (like DMSO) can facilitate the displacement of the palladium catalyst from the mono-coupled product, thus suppressing over-functionalization.^[7]
- **Control Stoichiometry:** While seemingly obvious, carefully controlling the stoichiometry of the boronic acid (using it as the limiting reagent) is a primary strategy. However, with highly reactive systems, di-functionalization can still occur.^[8]

- **Substrate Reactivity:** The relative reactivity of the halogen atoms also plays a role. For substrates with different halogens (e.g., bromo and chloro), coupling will preferentially occur at the more reactive site (typically C-Br over C-Cl).[9] For identical halogens, electronic and steric factors on the ring dictate selectivity.[10][11]

Side Reactions

Question 4: My reaction is producing a significant amount of a dehalogenated byproduct. What is the cause of this side reaction and how can I minimize it?

Dehalogenation is a common side reaction where the halogen atom on your starting material is replaced by a hydrogen atom, leading to a reduced yield of the desired cross-coupled product.

[6]

Mechanism of Dehalogenation: The primary culprit is often the formation of a palladium-hydride (Pd-H) species.[6] This can be generated through the reaction of the palladium complex with various components in the reaction mixture, such as amine bases, alcohol solvents, or even trace amounts of water.[2][6] This Pd-H species can then undergo reductive elimination with the aryl group attached to the palladium, resulting in the dehalogenated arene.[2]

Troubleshooting Dehalogenation:

- **Eliminate Hydride Sources:** If you suspect dehalogenation is occurring, identify and eliminate potential sources of hydrides.
 - **Base:** Amine bases can be a source of hydrides. Consider switching to inorganic bases like carbonates (e.g., K_2CO_3 , CS_2CO_3) or phosphates (e.g., K_3PO_4).[1][6]
 - **Solvent:** Alcohol solvents can also act as hydride donors. Switching to an aprotic solvent is advisable if dehalogenation is significant.[1]
- **Ligand Selection:** The choice of ligand can influence the propensity for dehalogenation. Screening different ligands, including bulkier, more electron-rich phosphines or NHC ligands, may mitigate this side reaction.[6]
- **Optimize Reaction Conditions:** Carefully increasing the reaction temperature can sometimes favor the desired cross-coupling over dehalogenation by accelerating the rate-limiting step of

the productive catalytic cycle.[6]

Data & Protocols

Table 1: General Troubleshooting Guide for Suzuki Coupling of Polyhalogenated Substrates

Observed Problem	Potential Cause(s)	Recommended Troubleshooting Steps
Low or No Conversion	Inactive catalyst, suboptimal conditions, poor reagent quality.[1]	- Ensure rigorous degassing and inert atmosphere.[1] - Use fresh, high-purity ligands and reagents.[1][5] - Screen different bases (e.g., K ₂ CO ₃ , K ₃ PO ₄ , Cs ₂ CO ₃).[3] - Optimize temperature; avoid excessive heat.[1]
Catalyst Precipitation (Palladium Black)	Catalyst decomposition due to instability.[1]	- Increase ligand-to-palladium ratio (1:1 to 4:1).[1] - Switch to more robust, bulky electron-rich phosphine or NHC ligands.[1] - Lower the reaction temperature.[1]
Poor Selectivity (Mono- vs. Di-substitution)	Catalyst remains coordinated to the mono-coupled product.[7]	- Screen less sterically hindered ligands.[7] - Add small amounts of a coordinating solvent (e.g., DMSO).[7] - Carefully control the stoichiometry of the limiting reagent.[8]
Significant Dehalogenation	Formation of a palladium-hydride (Pd-H) species.[6]	- Avoid amine bases and alcohol solvents.[1][2] - Use inorganic bases like K ₂ CO ₃ or K ₃ PO ₄ . [6] - Switch to aprotic solvents.[1]
Homocoupling of Boronic Acid	Presence of oxygen, inefficient transmetalation.[2]	- Ensure thorough degassing of the reaction mixture.[1] - Use a slight excess of the aryl halide.[5]

Experimental Protocol: General Procedure for Suzuki-Miyaura Coupling

This protocol provides a general starting point. Optimization for specific polyhalogenated substrates is essential.

Materials:

- Polyhalogenated aryl halide (1.0 mmol, 1.0 equiv)
- Arylboronic acid (1.1–1.5 equiv)
- Palladium pre-catalyst (e.g., Pd(OAc)₂, Pd₂(dba)₃; 1-5 mol%)
- Ligand (e.g., SPhos, XPhos, PPh₃; 1-2 times the mol% of Pd)
- Base (e.g., K₃PO₄, K₂CO₃; 2.0–3.0 equiv)
- Degassed solvent (e.g., Toluene/H₂O, Dioxane/H₂O)

Procedure:

- To a Schlenk flask or reaction vial, add the polyhalogenated aryl halide, arylboronic acid, and base.
- Seal the flask and purge with an inert gas (Argon or Nitrogen) by performing at least three vacuum-backfill cycles.
- Under a positive flow of inert gas, add the palladium pre-catalyst and ligand.
- Add the degassed solvent(s) via syringe.
- Heat the reaction mixture to the desired temperature (typically 80–110 °C) with vigorous stirring.^[1]
- Monitor the reaction progress using an appropriate analytical technique (e.g., TLC, LC-MS, GC-MS).
- Upon completion, cool the reaction to room temperature.

- Dilute the mixture with an organic solvent (e.g., ethyl acetate) and wash with water and brine.
- Dry the organic layer over anhydrous sodium sulfate or magnesium sulfate, filter, and concentrate under reduced pressure.
- Purify the crude product by column chromatography on silica gel.

Visualizing Key Concepts

The Suzuki-Miyaura Catalytic Cycle

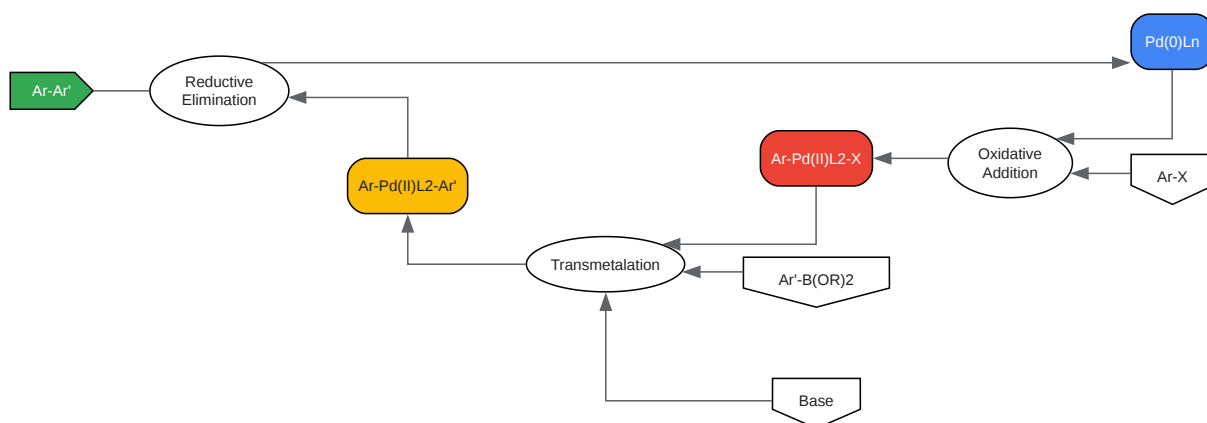

[Click to download full resolution via product page](#)

Caption: A simplified diagram of the Suzuki-Miyaura catalytic cycle.

Troubleshooting Logic Flow

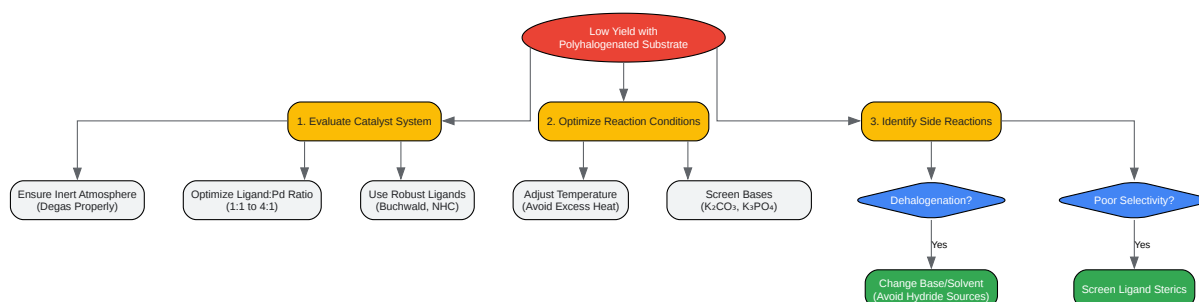

[Click to download full resolution via product page](#)

Caption: A flowchart for systematically troubleshooting low yields.

References

- BenchChem. (2025). Troubleshooting guide for sluggish or incomplete Suzuki coupling reactions.
- Bone, K. I., Puleo, T. R., & Bandar, J. S. (2024). Mechanistic Origin of Ligand Effects on Exhaustive Functionalization During Pd-Catalyzed Cross-Coupling of Dihaloarenes.
- Lehmler, H. J., & Robertson, L. W. (2001). Synthesis of polychlorinated biphenyls and their metabolites with a modified Suzuki-coupling. University of Iowa.
- Yoneda Labs. (n.d.). Suzuki-Miyaura cross-coupling: Practical Guide.
- BenchChem. (2025).
- Joshi, N. S., et al. (2011). Synthesis of polychlorinated biphenyls (PCBs) using the Suzuki-coupling. Request PDF.
- Newman, S. G., & Willis, M. C. (2012). Exhaustive Suzuki-Miyaura Reactions of Polyhalogenated Heteroarenes with Alkyl Boronic Pinacol Esters. PMC.
- BenchChem. (2025). A Comparative Guide to Base Selection in Suzuki Cross-Coupling Reactions.
- BenchChem. (2025). Troubleshooting low yield in Suzuki coupling of chloropyrimidines.

- Lehmler, H. J., et al. (2001). Synthesis of polychlorinated biphenyls (PCBs) using the Suzuki-coupling. PubMed - NIH.
- Norman, J. P., & Neufeldt, S. R. (2021). Site-Selective Cross-Coupling of Polyhalogenated Arenes and Heteroarenes with Identical Halogen Groups. Chemical Reviews.
- Norman, J. P., & Neufeldt, S. R. (2021). Site-Selective Cross-Coupling of Polyhalogenated Arenes and Heteroarenes with Identical Halogen Groups. PMC.
- Organic Chemistry Portal. (n.d.). Suzuki Coupling.

Need Custom Synthesis?

BenchChem offers custom synthesis for rare earth carbides and specific isotopic labeling.

Email: info@benchchem.com or [Request Quote Online](#).

Sources

- [1. pdf.benchchem.com \[pdf.benchchem.com\]](#)
- [2. Yoneda Labs \[yonedalabs.com\]](#)
- [3. pdf.benchchem.com \[pdf.benchchem.com\]](#)
- [4. Suzuki Coupling \[organic-chemistry.org\]](#)
- [5. pdf.benchchem.com \[pdf.benchchem.com\]](#)
- [6. pdf.benchchem.com \[pdf.benchchem.com\]](#)
- [7. Mechanistic Origin of Ligand Effects on Exhaustive Functionalization During Pd-Catalyzed Cross-Coupling of Dihaloarenes - PMC \[pmc.ncbi.nlm.nih.gov\]](#)
- [8. Exhaustive Suzuki-Miyaura Reactions of Polyhalogenated Heteroarenes with Alkyl Boronic Pinacol Esters - PMC \[pmc.ncbi.nlm.nih.gov\]](#)
- [9. Research Portal \[iro.uiowa.edu\]](#)
- [10. Site-Selective Cross-Coupling of Polyhalogenated Arenes and Heteroarenes with Identical Halogen Groups - PMC \[pmc.ncbi.nlm.nih.gov\]](#)
- [11. pubs.acs.org \[pubs.acs.org\]](#)
- To cite this document: BenchChem. [Technical Support Center: Troubleshooting Low Yields in Suzuki Coupling with Polyhalogenated Substrates]. BenchChem, [2026]. [Online PDF]. Available at: [<https://www.benchchem.com/product/b2579427/docs#technical-support-center-troubleshooting-low-yields-in-suzuki-coupling-with-polyhalogenated-substrates>]

Disclaimer & Data Validity:

The information provided in this document is for Research Use Only (RUO) and is strictly not intended for diagnostic or therapeutic procedures. While BenchChem strives to provide accurate protocols, we make no warranties, express or implied, regarding the fitness of this product for every specific experimental setup.

Technical Support: The protocols provided are for reference purposes. Unsure if this reagent suits your experiment?

Need Industrial/Bulk Grade? [Request Custom Synthesis Quote](#)

BenchChem

Our mission is to be the trusted global source of essential and advanced chemicals, empowering scientists and researchers to drive progress in science and industry.

Contact

Address: 3281 E Guasti Rd
Ontario, CA 91761, United States
Phone: (601) 213-4426
Email: info@benchchem.com

[Contact our Ph.D. Support Team for a compatibility check](#)